

NOTE: THIS DETAIL IS FROM PWS#2

THRUST BLOCK DIMENSIONS - INCHES													
PIPE DIA.	ALL FTGS.		TEE PLUG TAPPING			90 DEGREE BEND		45 DEGREE BEND		22-1/2 BEND		11-1/4 BEND	
	A	B	C	H	C	H	C	H	C	H	C	H	
4	14	4	24	12	26	15	18	12	12	12	12	12	
6	16	6	36	18	36	24	30	18	24	12	12	12	
8	20	8	36	30	42	36	36	24	24	18	18	12	
10	20	10	48	36	66	36	36	36	28	24	18	18	
12	24	12	68	36	82	42	52	36	40	24	28	18	

NOTE: FOR FITTINGS LARGER THAN 12", SPECIAL RESTRAINT DESIGNS ARE REQUIRED.

HORIZONTAL THRUST BLOCKING DETAIL "C"

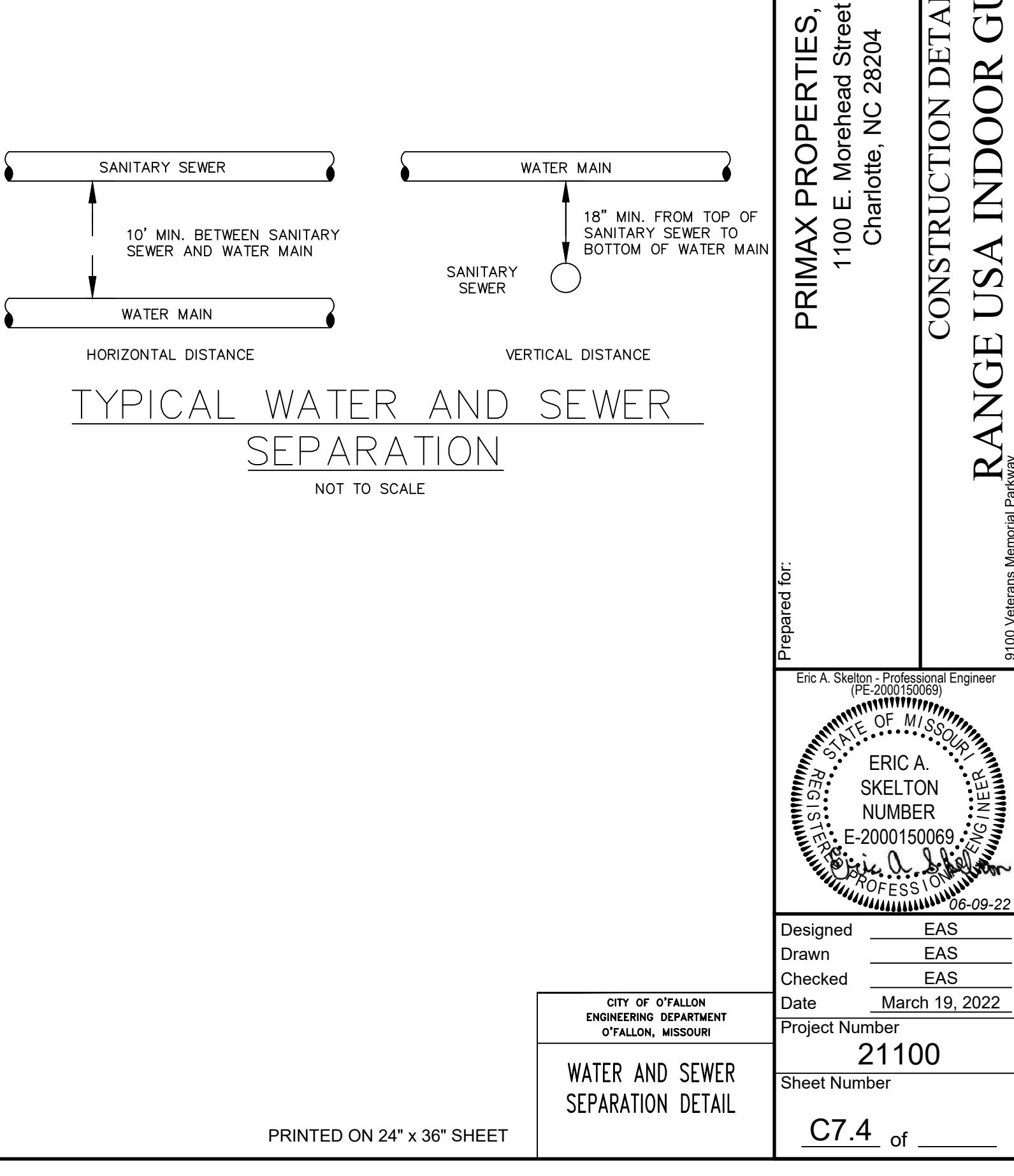
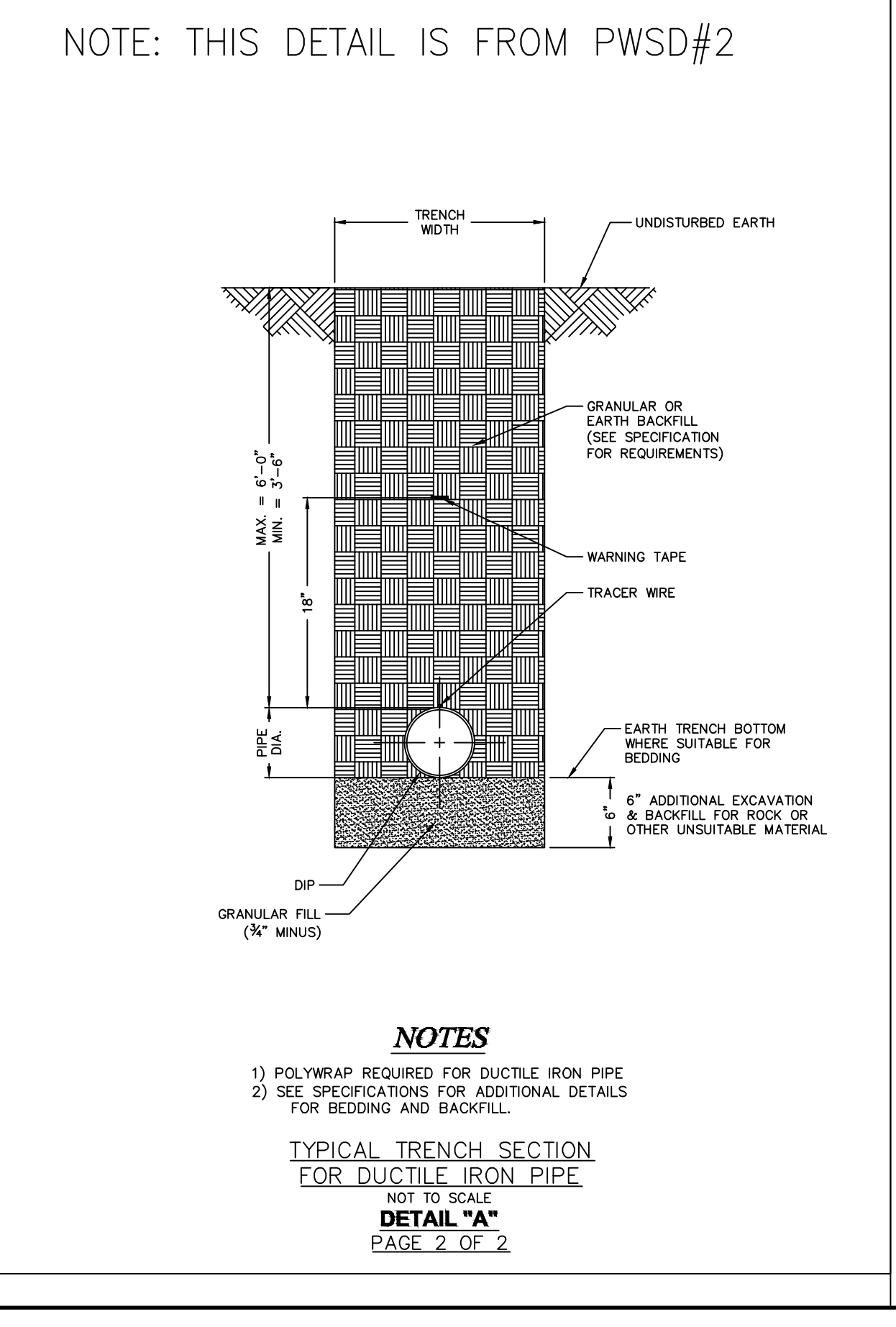
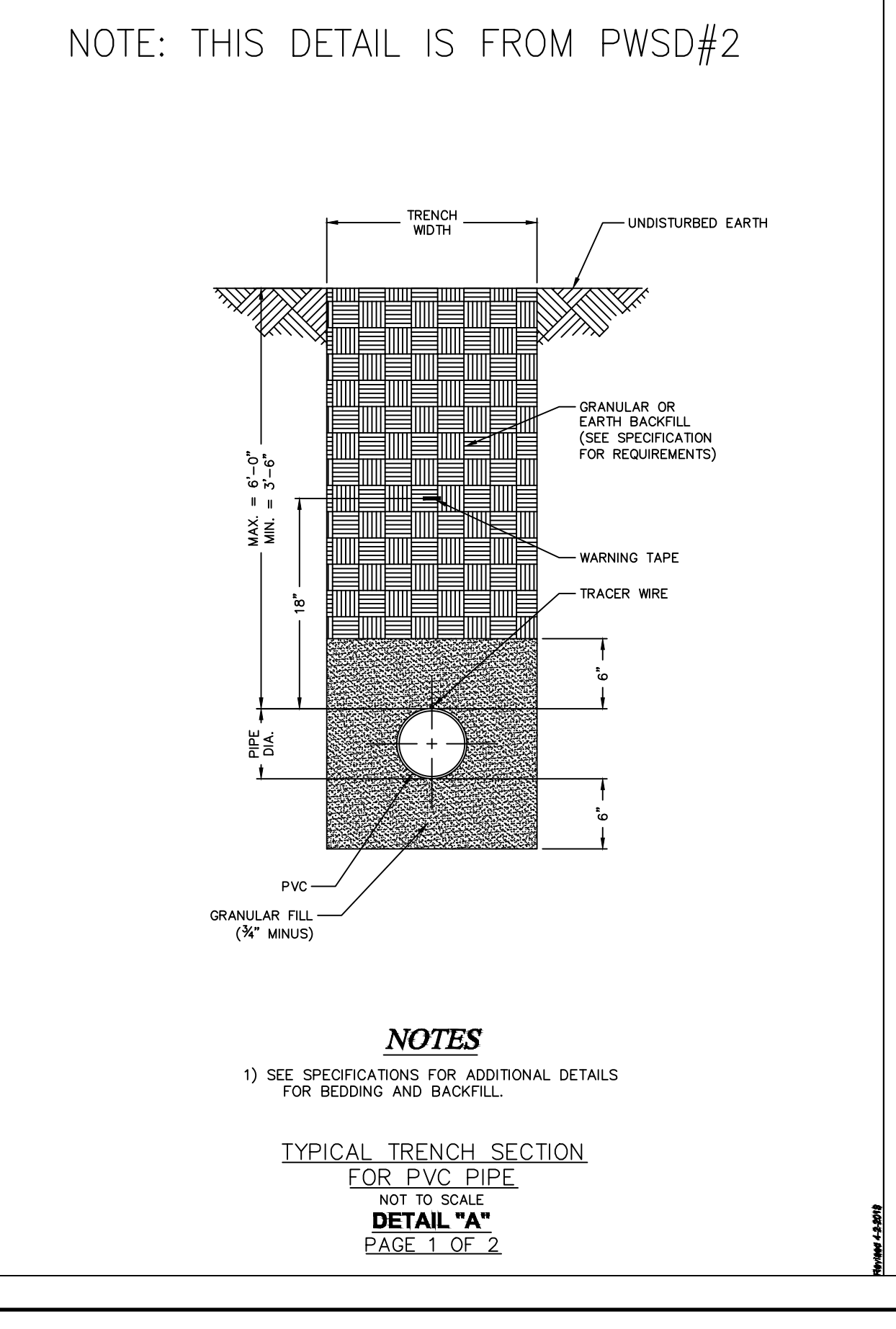
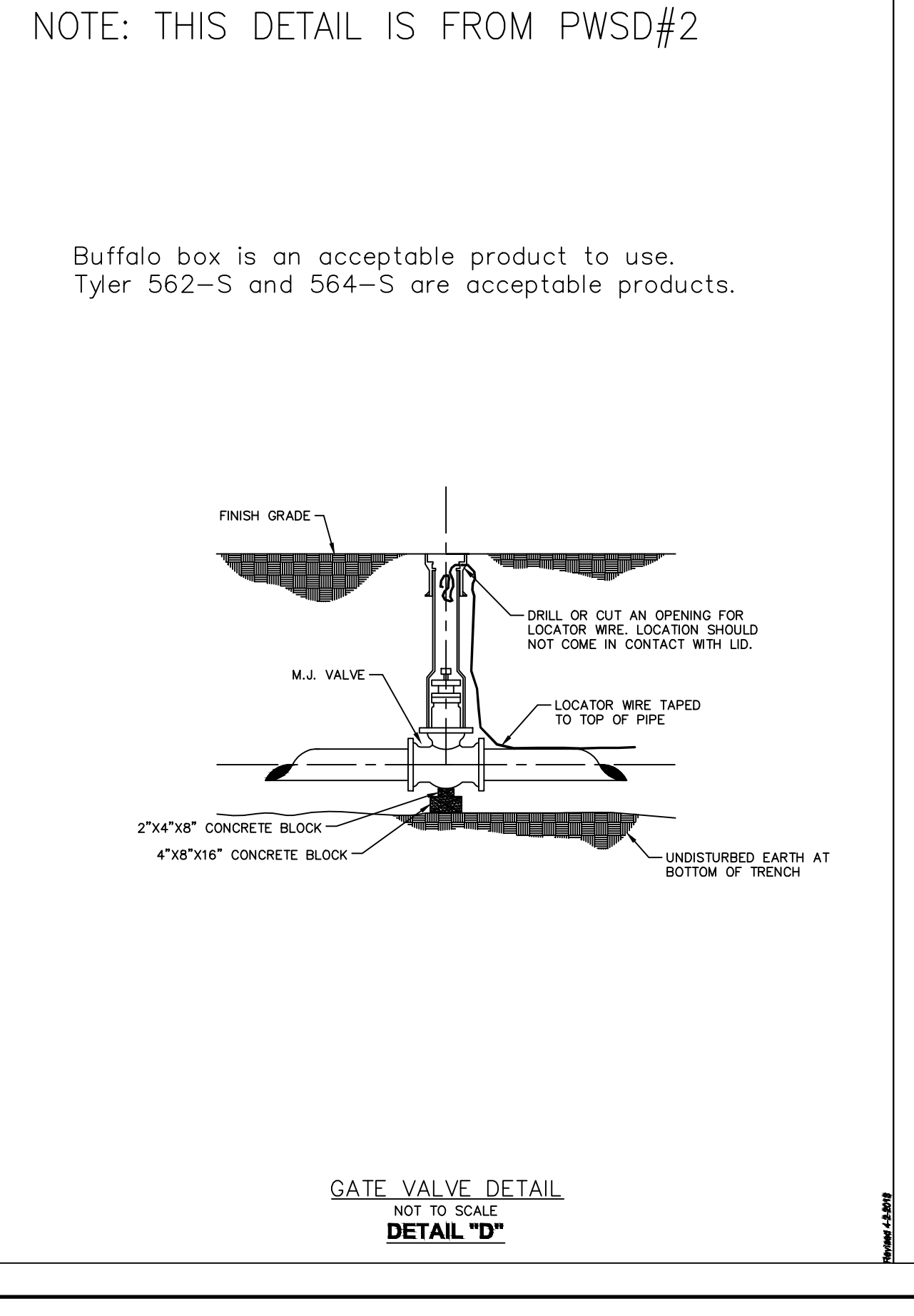

11/21/2013

11/21/2013

11/21/2013

Copyright 2022...
FILE: G:\2022\21003_RANGE_USA\Plan\Drawings\Shwppt-dtbl.dwg
PLOTTED: 06/20/2022 12:28 PM
O'Fallon, MO
F. B. 1440

Copyright 2022...
All Rights Reserved

the city design engineering company, inc.
ENGINEERS • SURVEYORS • PLANNERS
2208 WELSH INDUSTRIAL COURT
ST. LOUIS, MISSOURI 63146
(314) 682-8888 FAX: (314) 692-6688
info@citydesign.com
1400 Carondelet Avenue, Suite 200
St. Louis, Missouri 63102

REVISIONS

NO.	DATE	DESCRIPTION
2	04-26-22	EAS City of O'Fallon comments
4	05-13-22	EAS BID SET

CITY OF O'FALLON ENGINEERING DEPARTMENT O'FALLON, MISSOURI

WATER AND SEWER SEPARATION DETAIL