

DATE: 12-31-12  
 MARK DAVIS, CIVIL, LIC. # 024050  
 The State of Missouri Department of Professional Regulation (DPR) Inc., License No. Engineer: 001103, License No. Architect: 005620, License No. Survey: 003336

This document is only part of the total contract and/or construction document package. Other documents could contain information that may not be depicted here. The general contractor is responsible to provide all bidders with all information and documents pertaining to the complete scope of work.

The seal(s) and signature(s) apply only to the document to which they are affixed, and expressly disclaim any responsibility for all other plans, specifications, estimates, reports or other documents or instruments relating to or parts of the Architectural or Engineering project.

**PM/CM Services Environmental**  
 464 North Milwaukee  
 Chicago, Illinois 60610  
 (312) 684-5100

**Engineering Architecture Surveying**  
 8004 Esters Blvd., Suite 850  
 Irving, Texas 75063  
 (972) 967-3400

**DAVID MASON & ASSOCIATES**  
 800 South Vandeventer  
 St. Louis, Missouri 63110  
 (314) 534-1030

revisions number date

**DETAILS SAK CONSTRUCTION SITE IMPROVEMENTS**  
 864 HOFF ROAD  
 O'FALLON, MISSOURI

date 1-19-2011  
 job no. 2010003-00  
 ds. dr. ck.  
 sheet no.  
**C-7**

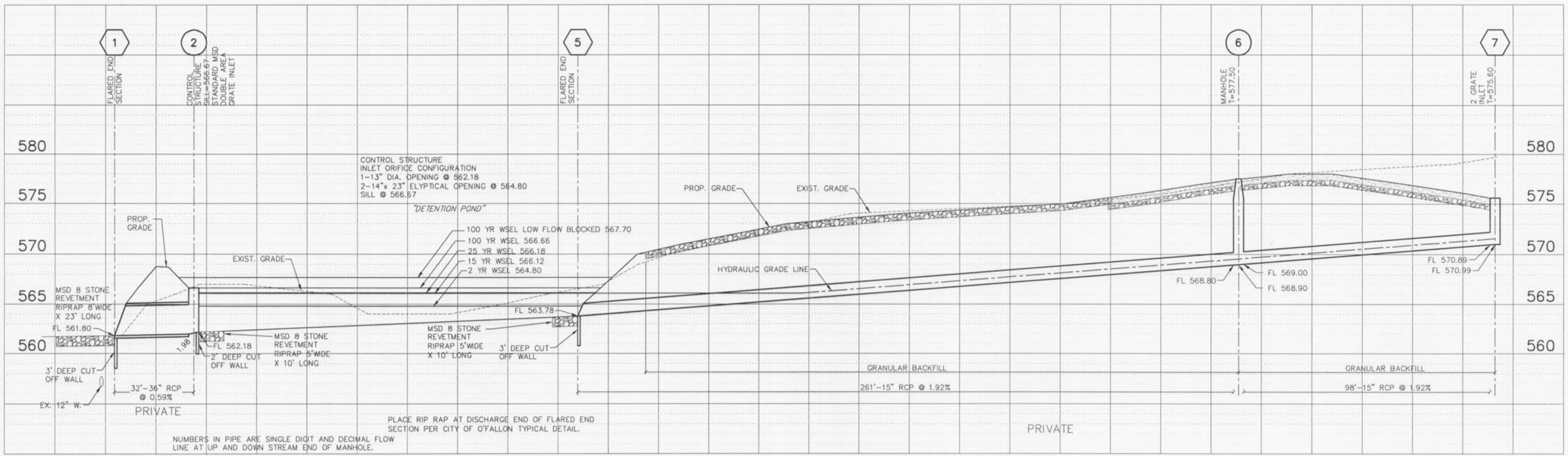

NOTE: PROVIDE A 0.20' DROP THRU STRUCTURES AND MANHOLES

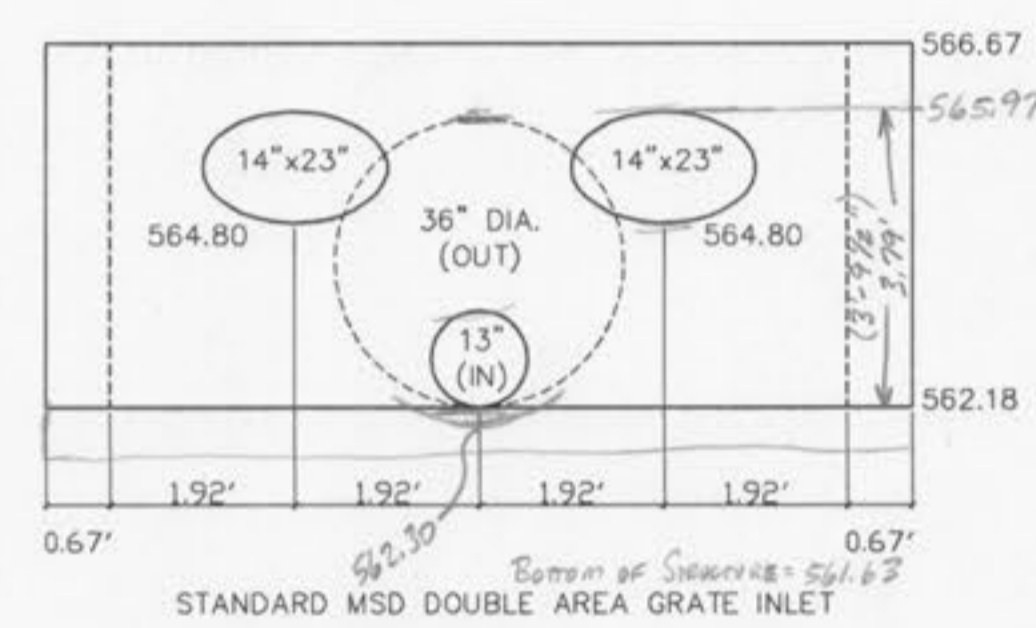
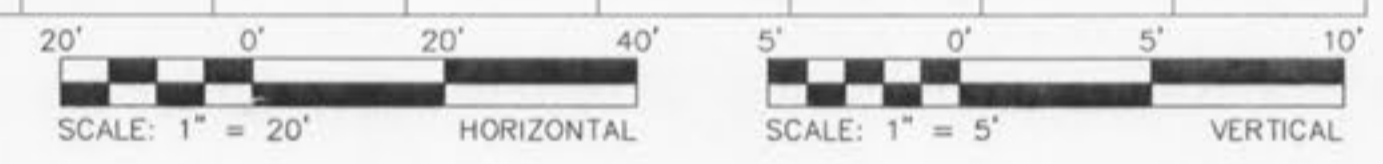

**CONTROL STRUCTURE**  
N.T.S.

PROVIDE STRAW BALE SILTATION CONTROL FROM THE BOTTOM OF THE SILTATION BASIN TO THE TOP OF THE 13\"/>

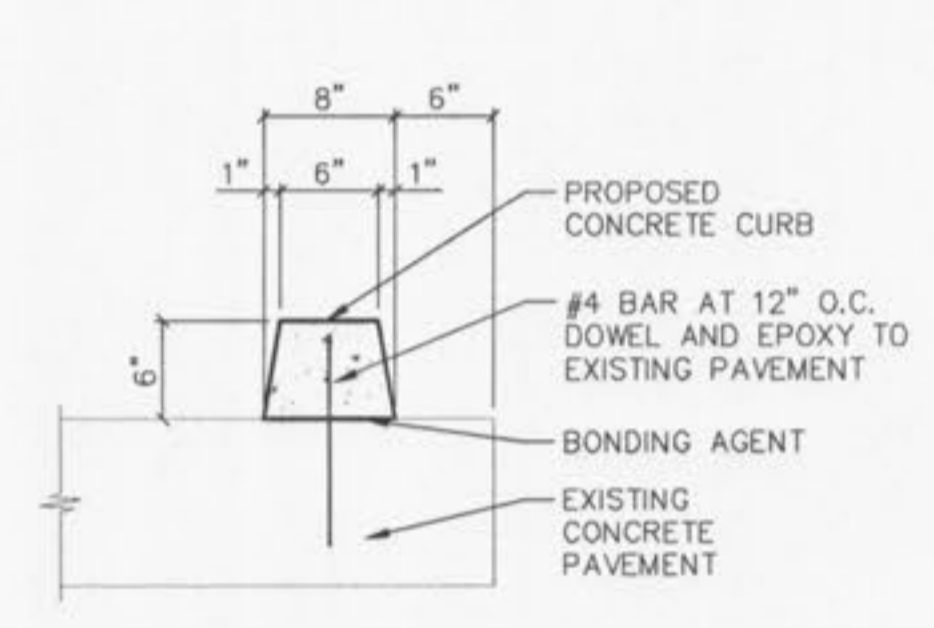

**MOUNTED CONCRETE CURB**  
N.T.S.

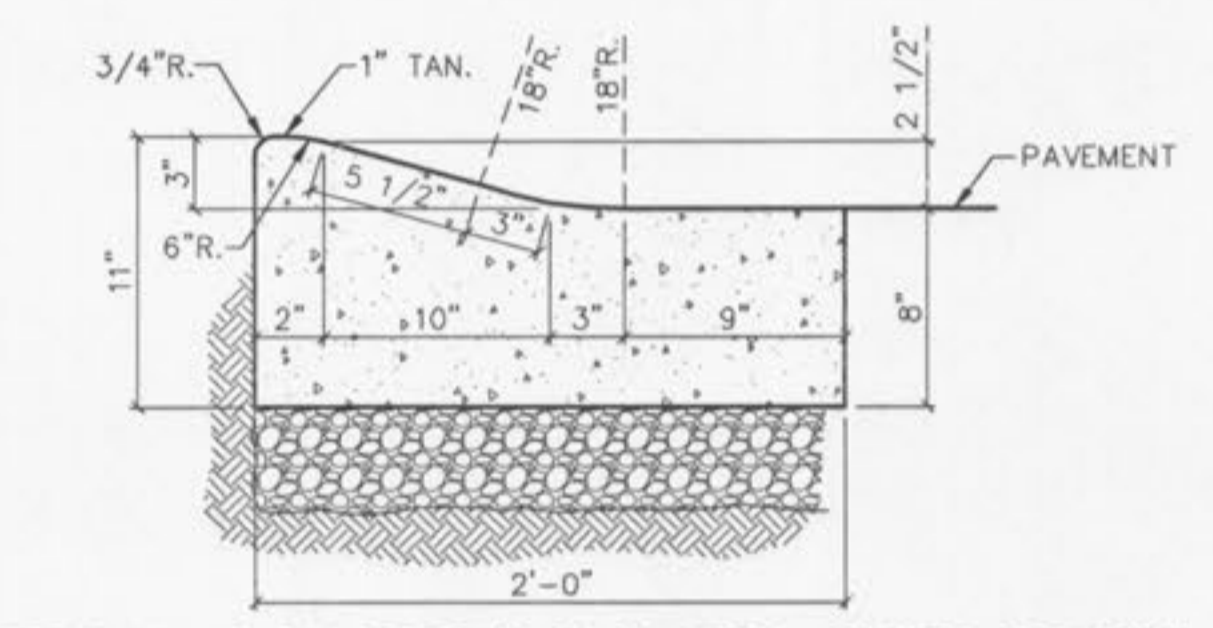

**INTEGRAL CONCRETE ROLLED CURB DETAIL**  
N.T.S.

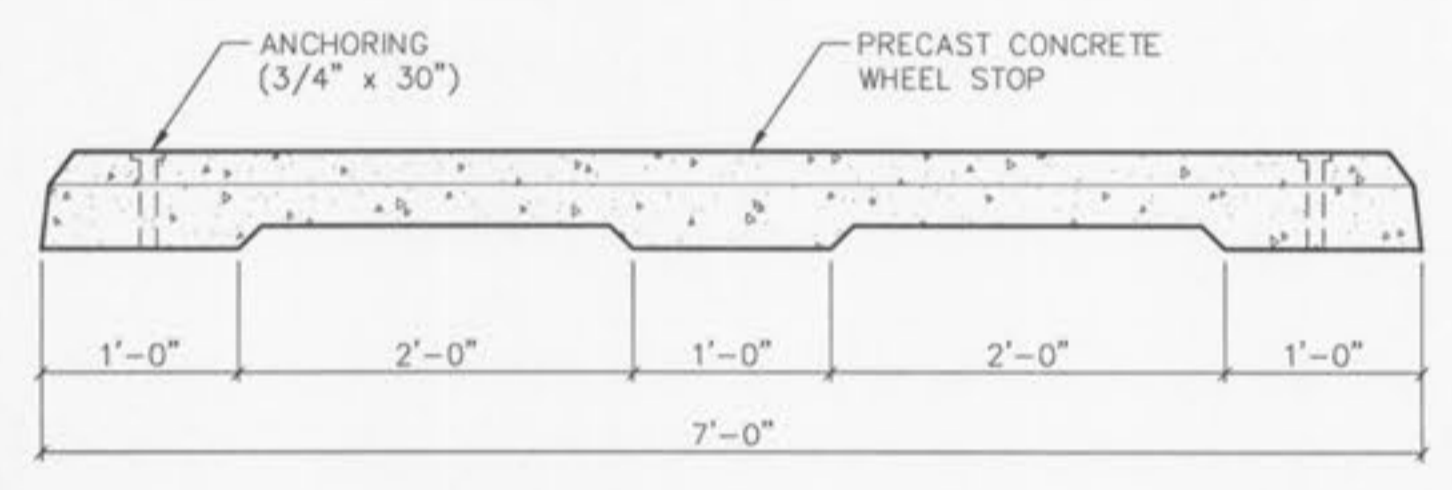

**PRECAST CONCRETE WHEEL STOP DETAIL**  
N.T.S.

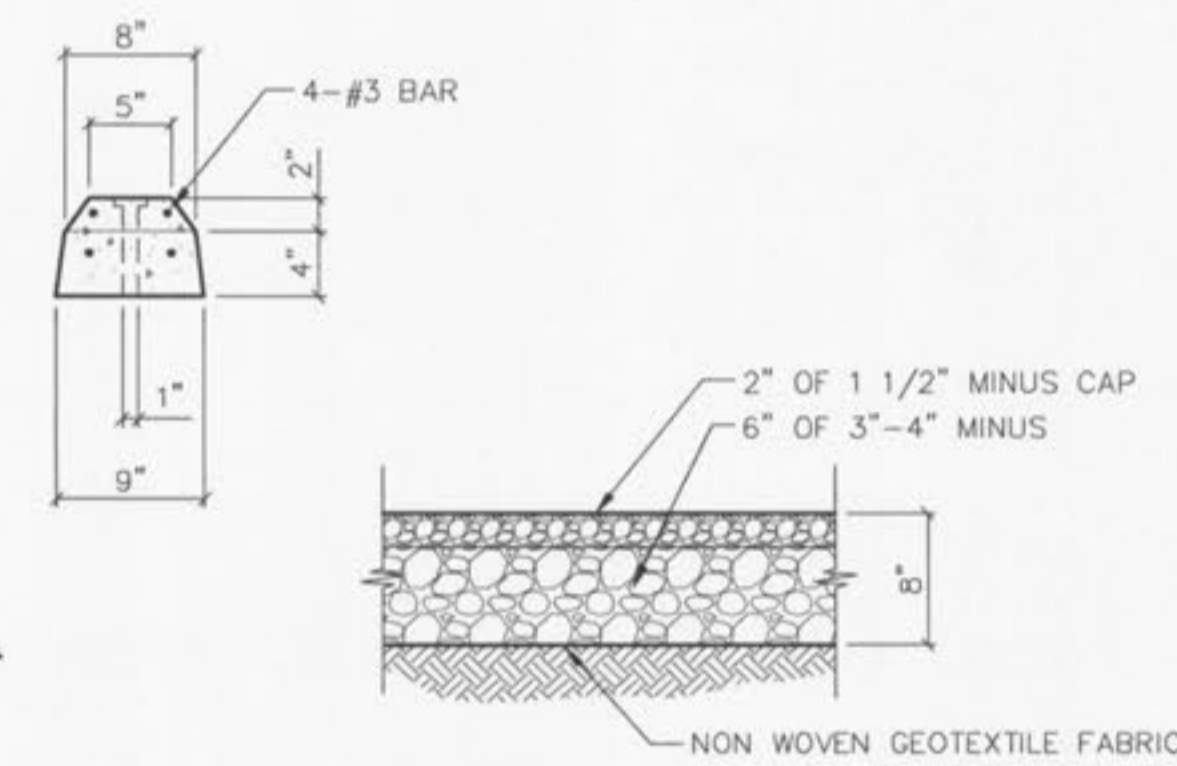

**GRAVEL PAVEMENT SECTION**  
N.T.S.

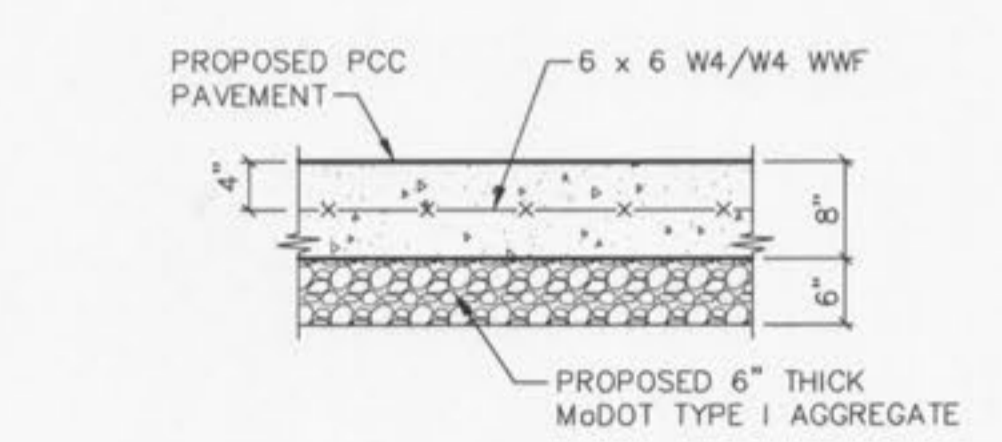

**CONCRETE PAVEMENT DETAIL**  
N.T.S.

ALL NON-REINFORCED CONCRETE SHALL BE 4000 PSI AT 28 DAYS.  
 ALL GRANULAR ROLLED STONE BASE UNDER PROPOSED CONCRETE MUST BE COMPACTED TO 100% OF THE MAXIMUM DENSITY AS DETERMINED BY THE STANDARD PROCTOR TEST AASHTO T-99.

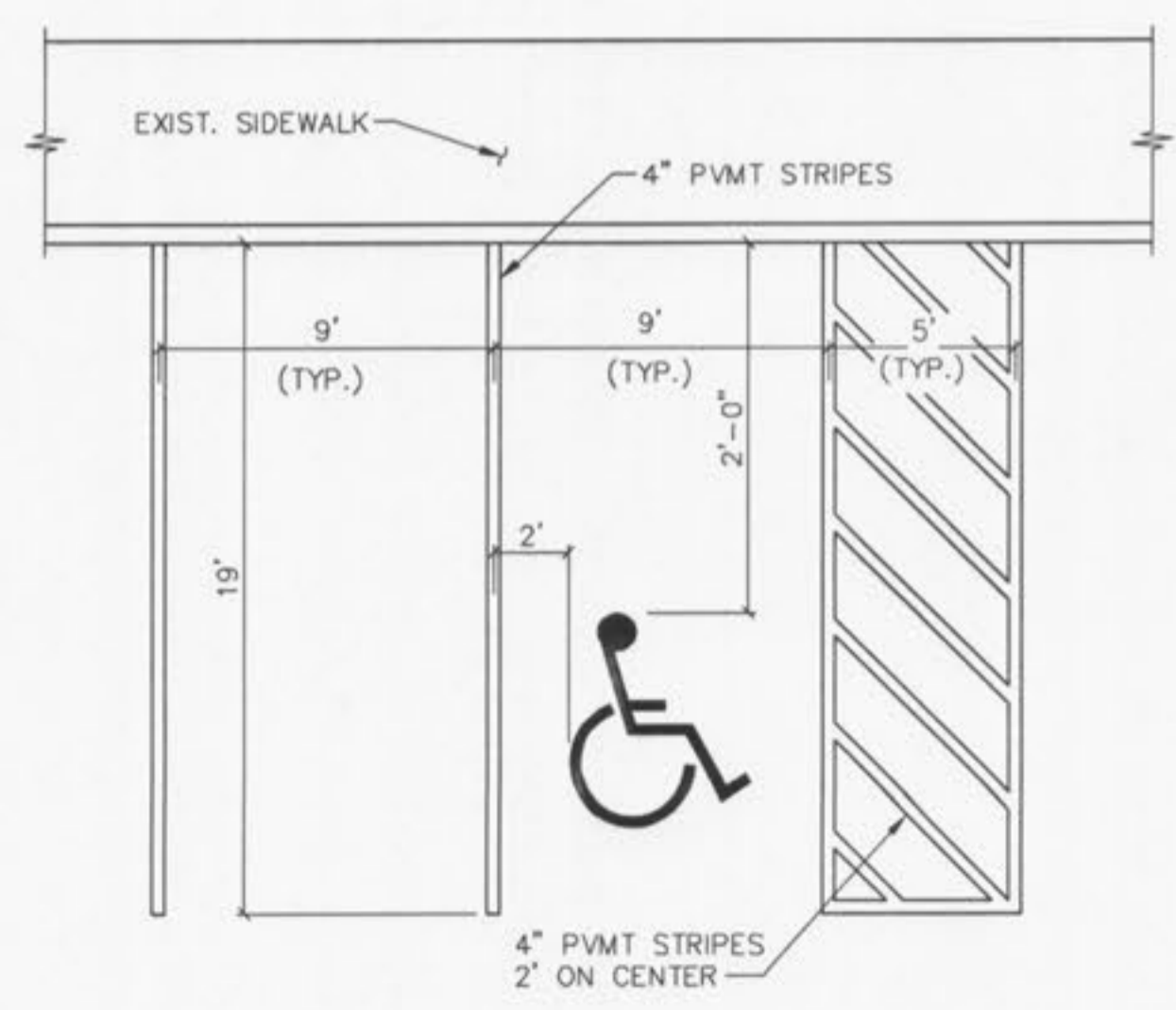

**HANDICAP PARKING SPACE DETAIL**  
N.T.S.



**TYPICAL HANDICAP SIGN**  
N.T.S.

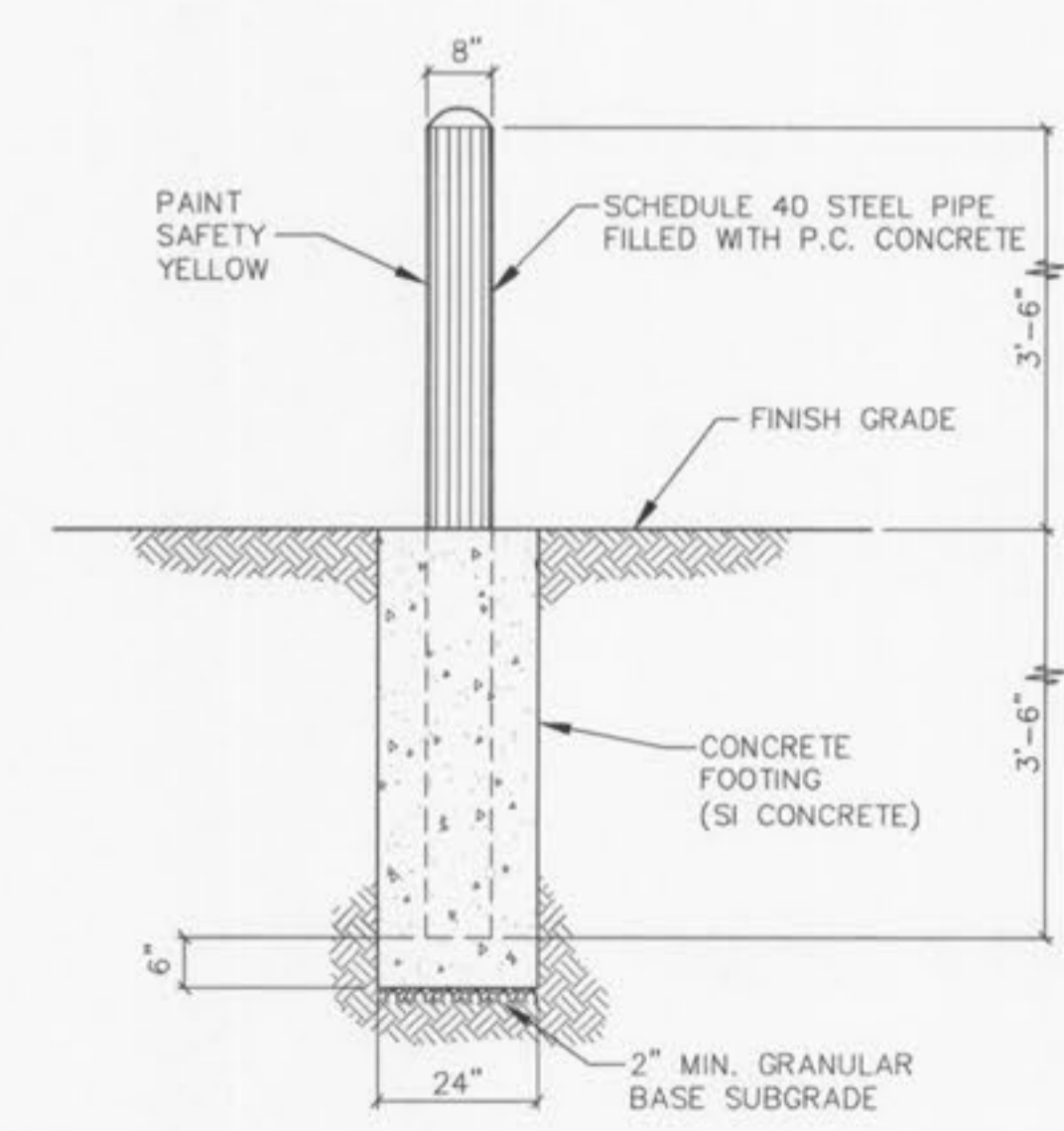

**BOLLARD DETAIL**  
N.T.S.

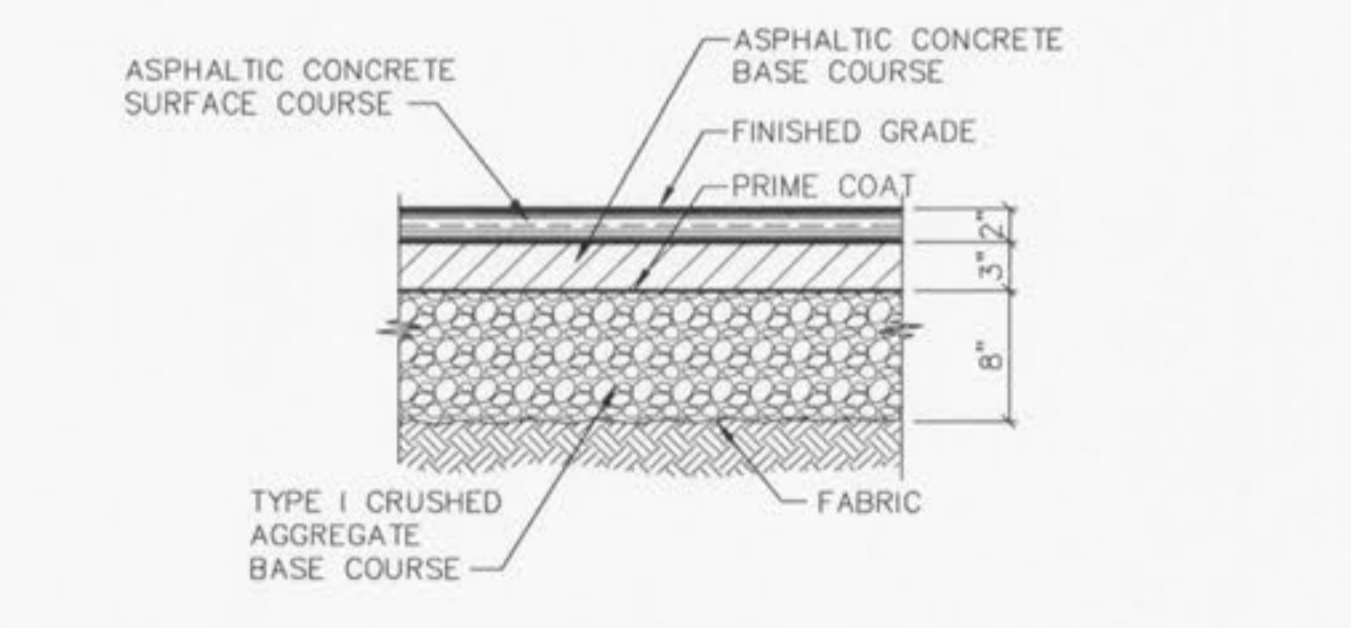

**ASPHALTIC CONCRETE PAVEMENT DETAIL**  
N.T.S.

CITY OF O'FALLON  
 THE ASPHALT SURFACE SHALL BE COMPACTED TO DEVELOPMENT DEPARTMENT DENSITY.  
 ACCEPTED FOR CONSTRUCTION BY: [Signature] DATE: 1/11/11  
 PROFESSIONAL ENGINEER'S SEAL  
 INDICATES RESPONSIBILITY FOR DESIGN & TITLE NUMBER 0408  
 APPROVAL DATE: JUNE 3, 2010