

MISSOURI DEPARTMENT OF TRANSPORTATION

D6 PERMITS TYPE III COMMERCIAL DRIVE

RECOMMENDED WIDTH 30 FEET

SHEET NO. 1 OF 2

CROSS SECTION	CONDITION		TREATMENT	SIGN	
	DIFFERENTIAL	TIME		MAINLINE (1)	SIDE ROAD (2)
1V:1H SLOPE OR FLATTER	PAVEMENT EDGE DIFFERENTIAL > 2" TO 5"	NON-WORKING HOURS	WEDGE SLOPE TO 1V:1H OR FLATTER	NO SIGNS REQUIRED	NO SIGNS REQUIRED
		WORKING HOURS	NO EDGE TREATMENT REQUIRED	NO SIGNS REQUIRED	NO SIGNS REQUIRED
1V:1H SLOPE OR FLATTER	PAVEMENT EDGE DIFFERENTIAL > 2" TO 5"	NON-WORKING HOURS	WEDGE SLOPE TO 1V:1H OR FLATTER	NO SIGNS REQUIRED	NO SIGNS REQUIRED
		WORKING HOURS	NO EDGE TREATMENT REQUIRED	NO SIGNS REQUIRED	NO SIGNS REQUIRED
1V:1H SLOPE OR FLATTER	PAVEMENT EDGE DIFFERENTIAL > 2"	NON-WORKING HOURS	WEDGE SLOPE TO 1V:1H OR FLATTER	NO SIGNS REQUIRED	NO SIGNS REQUIRED
		WORKING HOURS	DELINEATE DIFFERENTIAL WITH CHANNELIZERS	NO SIGNS REQUIRED	NO SIGNS REQUIRED
10" MIN.	ANY PAVEMENT EDGE OR LANE LINE DIFFERENTIAL	NON-WORKING AND WORKING HOURS	NO EDGE TREATMENT REQUIRED	NO SIGNS REQUIRED	NO SIGNS REQUIRED
		NON-WORKING AND WORKING HOURS	DELINEATE DIFFERENTIAL WITH CHANNELIZERS	NO SIGNS REQUIRED	NO SIGNS REQUIRED
LANE LINE	LANE LINE DIFFERENTIAL > 2"	NON-WORKING AND WORKING HOURS	NO EDGE TREATMENT REQUIRED	UNEVEN LANES	NO SIGNS REQUIRED
		NON-WORKING AND WORKING HOURS	WEDGE SLOPE TO 1V:1H OR FLATTER	UNEVEN LANES	NO SIGNS REQUIRED
LANE LINE	LANE LINE DIFFERENTIAL > 2"	NON-WORKING AND WORKING HOURS	WEDGE SLOPE TO 1V:1H OR FLATTER	UNEVEN LANES	NO SIGNS REQUIRED
		NON-WORKING AND WORKING HOURS	DELINEATE DIFFERENTIAL WITH CHANNELIZERS	UNEVEN LANES	NO SIGNS REQUIRED

LEGEND:
 [Symbol] RIGID PAVEMENT
 [Symbol] FLEXIBLE PAVEMENT
 [Symbol] ALL PAVEMENT TYPES

GENERAL NOTES:
 SIGNS SHALL BE VISIBLE TO TRAFFIC ONLY WHEN AND WHERE CONDITIONS EXIST.
 FOR ADDITIONAL SIGN SPACING AND DETAILS SEE STANDARD PLAN 620-10.

MISSOURI HIGHWAYS AND TRANSPORTATION COMMISSION
 DATE EFFECTIVE: 12/01/2012
 DATE PREPARED: 8/24/2012
 SHEET NO. 619.10J 1 OF 1

(1) SIGNS SHALL BE SPACED AT APPROXIMATELY ONE MILE INTERVALS AND LOCATED WITHIN 150 FT. BEYOND ANY STATE ROUTE. WHEN A SIGN PLACED AT THE ONE MILE INTERVAL FALLS WITHIN 1/2 MILE OF A SIGN PLACED AT THE 1/2 MILE INTERVAL, THE SIGN PLACED AT THE 1/2 MILE INTERVAL MAY BE OMITTED. WHEN SHOULDER DROPOFF EXIST ON DIVIDED LANES AND BOTH SPECIFIED, ALTERNATING SIGN MESSAGES SHALL BE USED AT 1/2 MILE SPACING.

(2) ON SIDE ROADS WITH POSTED SPEED OF 45 MPH OR GREATER, SIGNS SHALL BE PLACED 150 FT. IN ADVANCE OF INTERSECTION WITH MAINLINE.

(3) SIGNS SHALL BE LOCATED ON THE SIDE OF THE ROADWAY WHERE THE PAVEMENT EDGE DIFFERENTIAL EXISTS.

(4) SIGNS TO REMAIN VISIBLE UNTIL SHOULDER SHAPING IS COMPLETE.

(5) SIGNS SHALL BE LOCATED ON RIGHT SIDE OF NON-DIVIDED HIGHWAYS AND ON BOTH SIDES OF DIVIDED HIGHWAYS WHERE A LANE LINE DIFFERENTIAL EXISTS.

(6) WHEN THE SHOULDER DROPOFF SIGNS ARE IN PLACE FOR GREATER THAN THREE DAYS, THE SHOULDER DROPOFF PLACED SHOULD BE USED IN ADDITION WITH THE SHOULDER DROPOFF SIGN.

616.8.10 (TA-10) Lane Closure on Two-Lane Highways With Edgelines Using Flaggers

SPEED	SIGN SPACING (ft)	TAPER LENGTH (ft)	OPTIONAL CHANNELIZER SPACING (ft)				
Permanent Posted (mph)	Undivided (S)	Divided (S)	Shoulder (T1)	Lane (T2)	BUFFER LENGTH (ft)	Tapers	Channelizer Work Areas
0-35	200	-	-	-	280	-	40
40-45	350	-	-	-	400	-	80
50-55	500	-	-	-	560	-	80
60-70	1000	-	-	-	840	-	120

1. Shoulder taper length based on 10 ft. (standard shoulder width) offset. 2. Lane taper length based on 12 ft. (standard lane width) offset.

TYPE OF ROADWAY	SIGN HEIGHT	MAXIMUM WORK ZONE LENGTH (L)	Channelizer	Sign	Protective Vehicle
URBAN	7' Portable	1 ML	Truck or Trailer Mounted Arrow Panel	Truck Mounted Attenuator (TMA)	Work Space
RURAL UNDIVIDED	7' Portable	3 ML	Flagger	(Advanced Warning Rail System) For Long Term Operations	

A protective vehicle shall be used while work is in progress. The protective vehicle should be equipped with a TMA and flashing arrow panel and positioned at least 150 ft. in advance of the work space.

If a flashing arrow panel is used, the caution mode shall be displayed.

When a temporary road closure is needed, both directions may be stopped at the same time up to a maximum of 20 minutes.

Where operational conditions warrant, channelizing devices may be eliminated.

For short duration operations, signs and channelizers may be reduced or eliminated. The protective vehicle may be eliminated if adequate sight distance exists and the work vehicle uses activated rotating lights or strobe lights.

Vehicle hazard warning signals shall not be used instead of the vehicle's rotating lights or strobe lights.

For mobile operations where workers are on foot and move with the operation, channelizers may be reduced or eliminated.

Additional warning signs shall be erected at each intersection with another state highway within the work zone. Upon the discretion of the supervisor, additional warning signs may be erected at other intersections within the work zone.

For mobile operations, spacing between flagger and FLAGGER AHEAD signs shall not exceed one mile.

At night, flagger stations shall be illuminated.

For long-term operations, refer to EPG 616.6.2.2 Flags and Advance Warning Rail System.

If rumble strips are used, review EPG 616.6.8.7 RUMBLE STRIPS.

For work zone located in the vicinity of a railroad grade crossing, refer to EPG 616.6.46 (TA-46) Work in the Vicinity of a Grade Crossing.

SEE EPG 616.12 WORK ZONE SPEED LIMITS FOR SPEED LIMIT GUIDELINES.

TA-10 1/16

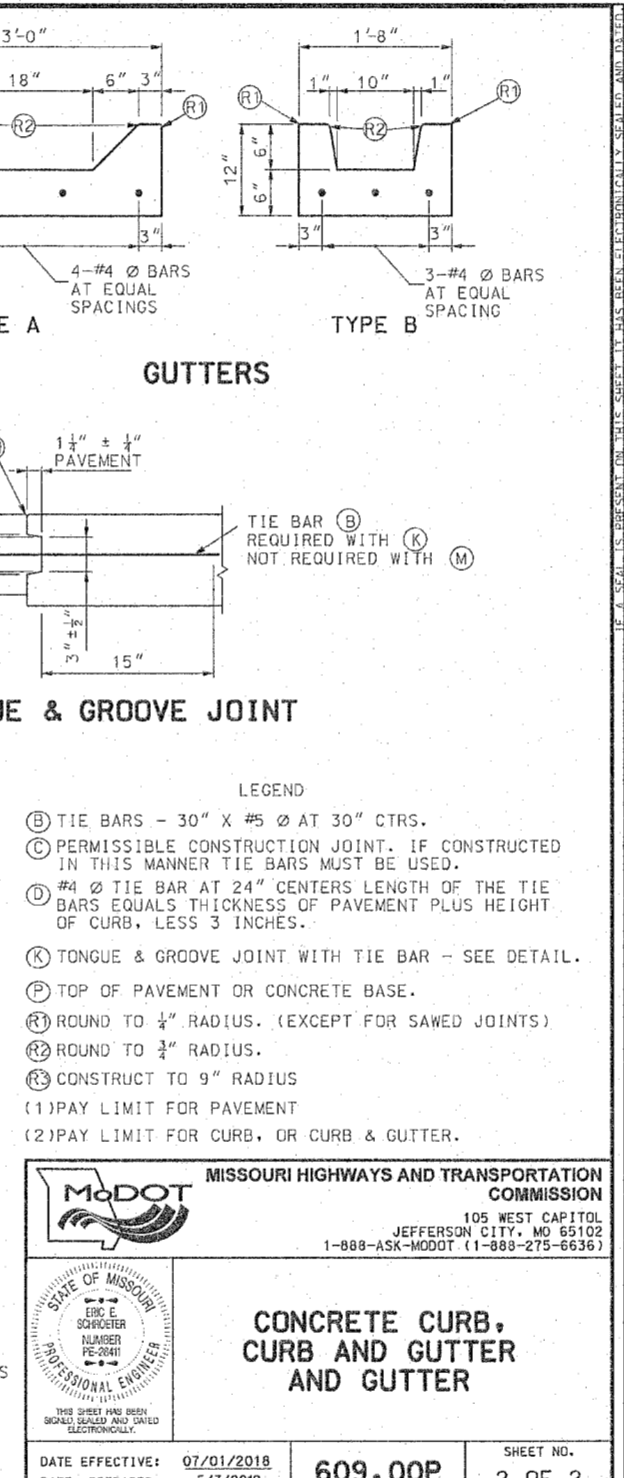
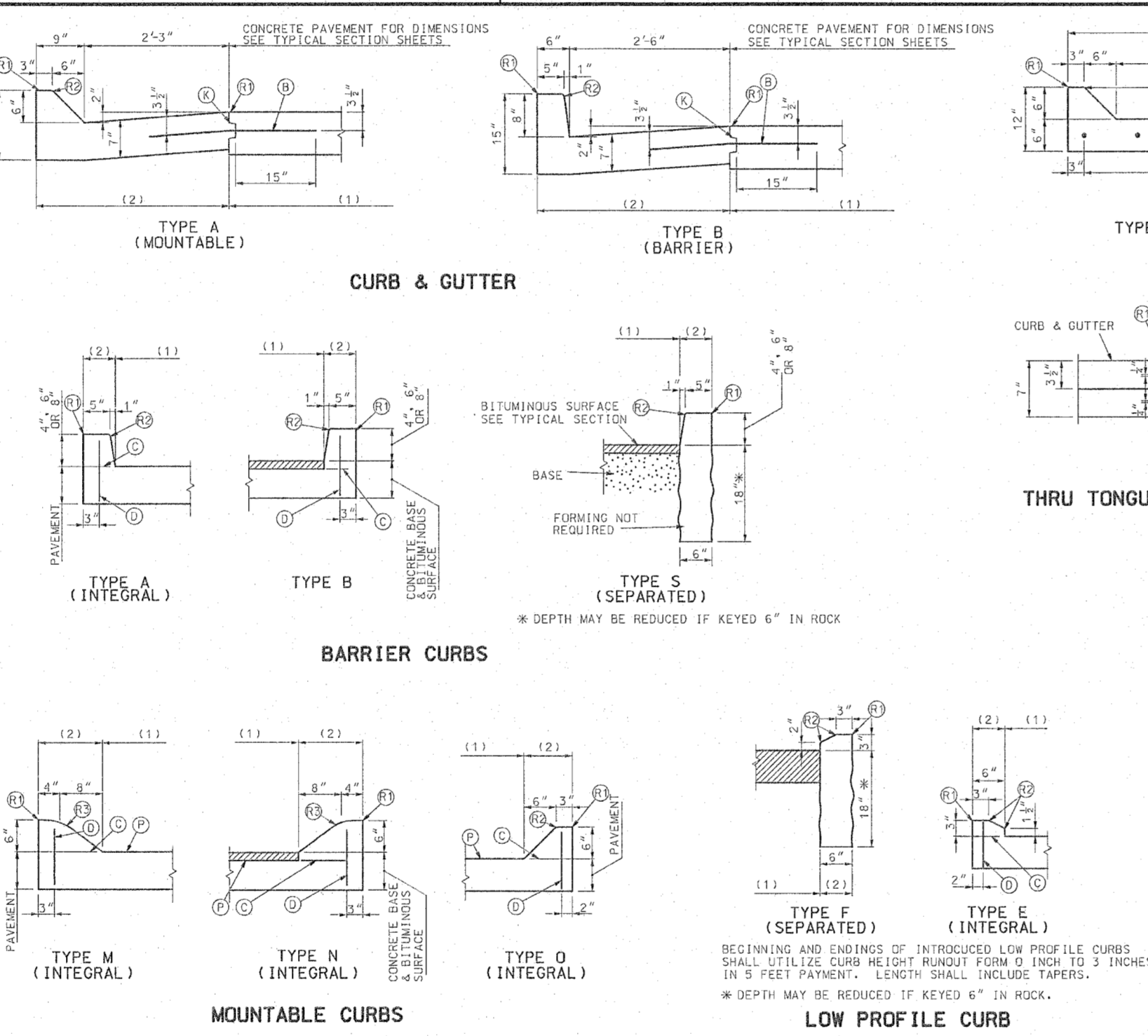

ENGINEERS SEAL DOES NOT APPLY TO TRAFFIC CONTROL OR MODOT DETAILS ON THIS SHEET

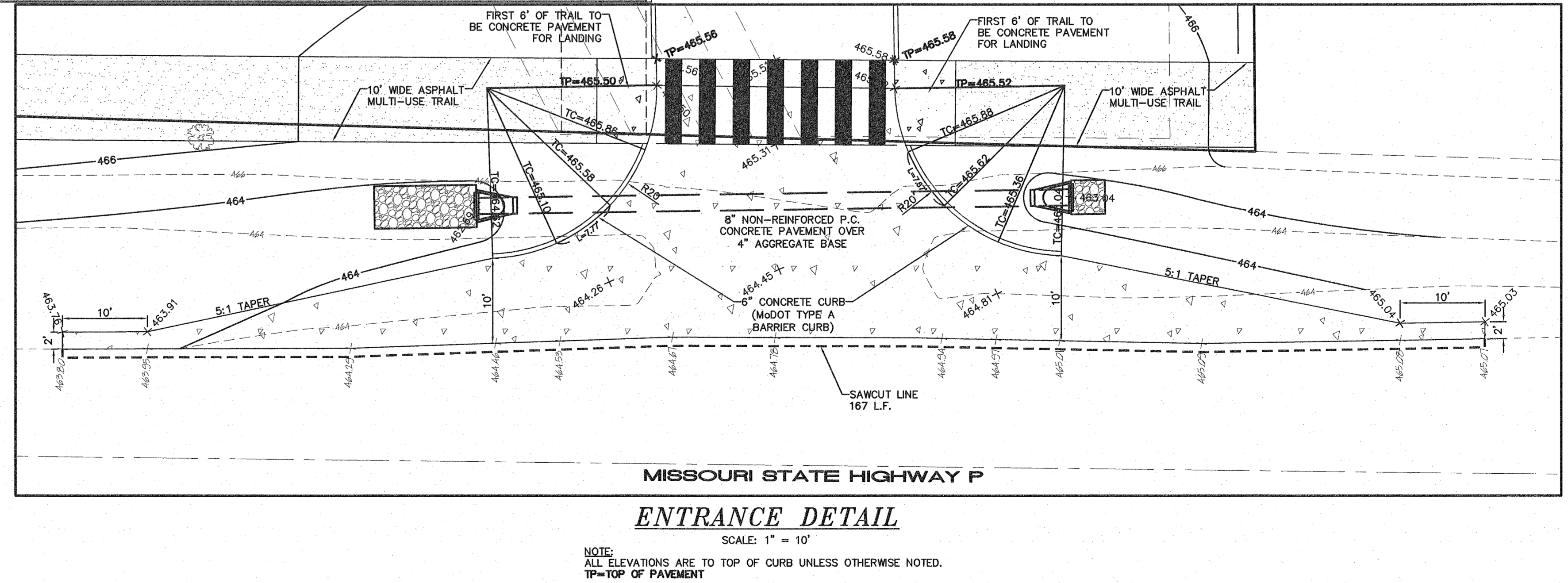

PROJECT TITLE: SHANE ESTATES

4572 HIGHWAY P
CITY OF OFALLON
ST. CHARLES COUNTY, MO. 63366

ENGINEERING PLANNING SURVEYING
 221 Point West Blvd.
 St. Charles, MO 63301
 636-928-9552
 FAX 636-928-1718

Clifford L. Heitmann
 Civil Engineer
 E29817
 Box Engineering Company, Inc.
 Missouri State Certificate of Authority
 Engineering #000655

REVISIONS

DATE	CITY COMMENTS
07/05/18	CITY COMMENTS
07/17/18	CITY COMMENTS
08/31/18	MODOT COMMENTS
09/12/18	MODOT COMMENTS
12/10/18	CLIENT COMMENTS
01/09/19	CITY COMMENTS

Developer / Owner: ELLA REAL PROPERTY HOLDINGS, L.L.C.
 428 NORTH MAIN STREET
 OFALLON, MO 63366
 (636) 577-2458

P+Z No. 18-000613
Approval Date: 04/05/2018
Page No. 11 of 12