

GENERAL NOTES PERTINENT TO ALL CONSTRUCTION OPERATIONS

- Underground utilities shown on these plans have been plotted from available records and information, and their locations shall be considered approximate only. The verification of the actual location of all underground utilities, either shown or not shown on these plans, shall be the responsibility of the contractor(s), and the verification of the actual location shall be performed prior to beginning work.
- Easements and right-of-ways will be provided for streets, sanitary sewers, storm sewers, water mains and private utilities on the subdivision plat (record plat). See the subdivision plat (record plat) for location and size of easements and right-of-ways.
- All construction shall be performed in accordance with the specifications, ordinances, rules, regulations, guidelines and/or policies of the local governing jurisdictional authority. The City of St. Peters will be provided a copy of all grading compaction test results.

GRADING NOTES

- No area shall be cleared without authorization from the project engineer.
- All grading work performed shall be within a 0.2 foot tolerance of the grades shown on the grading plan. Maximum slopes to be 3 horizontal to 1 vertical.
- A Geotechnical Engineer shall be employed by the owner and be on site during grading operations.
- The grading contractor shall perform a complete grading and compaction operation as shown on the plans, stated in these notes, or reasonably implied therefrom, all in accordance with the plans and notes as interpreted by the Geotechnical Engineer.
- Before the grading begins, the owner shall employ a competent, licensed surveyor to establish all lines and grades.
- The contractor shall notify the Geotechnical Engineer at least two days in advance of the start of the grading operation.
- The contractor shall notify the City of St. Peters Engineering Department at least 2 days prior to the start of grading operations. Telephone: (636) 477-6600, ext. 670.

II. SPECIFICATIONS

- Site preparation includes the clearing of all stumps, trees, bushes, shrubs, and weeds; the grubbing and removal of roots and other surface obstructions from the site; and the demolition and removal of any man-made structures. The unsuitable material shall be burned (after securing permits) and/or properly disposed of on site. Topsoil and grass in the fill areas shall be thoroughly disced prior to the placement of any fill. The Geotechnical Engineer shall approve the discing operation.
- Compaction equipment shall consist of tamping rollers, pneumatic-tired rollers, vibratory rollers, or high speed impact type drum rollers acceptable to the Geotechnical Engineer. The roller shall be designed so as to avoid the creation of a layered fill without proper blending of successive fill layers.
- Observation and Testing: The Geotechnical Engineer shall observe and test the placement of the fill to verify that specifications are met. A series of fill density tests will be determined on each lift of fill. Interim reports showing fill quality will be made to the owner at regular intervals.
- The Geotechnical Engineer shall notify the contractor of rejection of a lift of fill or portion thereof. The contractor shall rework the rejected portion of fill and obtain notification from the Geotechnical Engineer of its acceptance prior to the placement of additional fill.
- Placing and Compaction of Fill: All areas to receive fill shall be scarified to a depth of not less than 6 inches and then compacted to at least 85 percent of the maximum dry density as determined from the modified Proctor compaction test (ASTM-D-1557). Natural slopes steeper than 1 vertical to 5 horizontal to receive fill will have horizontal benches, with minimum widths of 12 feet and maximum height of 5 feet, cut into the slopes before the placement of any fill. The fill shall be loosely placed in horizontal layers not exceeding 8 inches in thickness and compacted in accordance with the specifications given below. The Geotechnical Engineer shall be responsible for determining the acceptability of the soils placed. Any unacceptable soils placed shall be removed at the contractor's expense.
- The sequence of operation in the fill areas will be fill, compact, verify acceptable soil density, and repetition of the sequence. The acceptable moisture contents during the filling operation in the remaining areas are from 2 to 8 percent above the optimum moisture control.
- The surface of the fill shall be finished so that it will not impound water. If at the end of a day's work, it would appear that there may be rain prior to the next working day, the surface shall be finished smooth. If the surface has been finished smooth for any reason, it shall be scarified before proceeding with the placement of succeeding lifts. Fill should not be placed on frozen ground, nor shall filling operations continue when the temperature is such as to permit the layer under placement to freeze.
- All fills shall be compacted to 90% of maximum density as determined by the "Modified AASHTO T-1800 Compaction Test" (ASTM D-1557).
- Fills in rear yard areas only shall be compacted, but the compaction criteria may be reduced to 85% of maximum density as determined by the "Modified AASHTO T-1800 Compaction Test" (ASTM D-1557).
- All filled places under proposed storm and sanitary sewer lines and/or paved areas including trench backfills within and off the road right-of-way shall be compacted to 90 percent of maximum density as determined by the "Modified AASHTO T-180 Compaction Test" (ASTM D-1557). All tests shall be verified by a Soils Engineer concurrent with grading and backfilling operations.
- All filled places in proposed and existing City of St. Peters roads (highways) shall be compacted from the bottom of the fill up to 90 percent maximum density as determined by the "Modified AASHTO T-180 Compaction Test" (ASTM D-1557). All tests shall be verified by a Soils Engineer concurrent with grading operations.

PAVEMENT CONSTRUCTION

I. GENERAL

- The paving contractor shall perform a complete installation as shown on the plans, stated in these notes, or reasonably implied therefrom, all in accordance with the plans, and notes as interpreted by the project engineer.
- Before street paving begins, the owner shall employ a competent, licensed surveyor to establish the lines and grades of the street pavement being constructed.
- The contractor shall notify the City Engineer at least two days in advance of the start of construction. Contact City of St. Peters, at telephone (636) 477-6600.

II. SPECIFICATIONS

- All materials used shall meet the following specifications:
 Rolled Stone Base: Rolled Stone Base used shall meet the requirements for Type 5 Aggregate as specified in Section 1007 of the "Missouri Standard Specifications for Highway Construction, 1996".
 P.C. Concrete: P.C. Concrete used shall meet the requirements for Pavement Concrete as specified in Section 502 of the "Missouri Standard Specifications for Highway Construction, 1996".
 Asphaltic Concrete: A.C. used shall meet the requirements for Pavement Concrete as specified in Section 403 of the "Missouri Standard Specifications for Highway Construction, 1996".
- All areas to receive paving shall first have the earth subgrade prepared in accordance with the requirements of Section 209 of the "Missouri Standard Specifications for Highway Construction, 1996".
- Areas within the City Street rights-of-way shall have P.C. Concrete pavement installed on the earth subgrade in accordance with the City of St. Peters Design Criteria and Standard Specifications for Street Construction.
- All paving work shall be performed in accordance with the City of St. Peters specifications. The contractor shall assist City personnel or City representatives in the inspection and testing of the paving work.

VEGETATIVE ESTABLISHMENT FOR URBAN DEVELOPMENT SITES

APPENDIX A

SEEDING RATES:

Permanent:

- Tall Fescue - 30 lbs./ac.
- Smooth Brome - 20 lbs./ac.
- Combined: Fescue@15 lbs./ac. and Brome@10 lbs./ac.

Temporary:

- Wheat or Rye - 150 lbs./ac.(3.5 lbs. per 1000 sq. ft.)
- Oats - 120 lbs./ac.(2.75 lbs. per 1000 sq. ft.)

SEEDING PERIODS

- Fescue or Brome March 1 to June 1
- August 1 to October 1
- Wheat or Rye March 15 to November 1
- Oats March 15 to September 15

MULCH RATES: 100 lbs. per 1000 sq.ft.(4,356 lbs. per acre)

- FERTILIZER RATES:**
- Nitrogen 30 lbs./ac.
 - Phosphate 30 lbs./ac.
 - Potassium 30 lbs./ac.
 - Lime 600 lbs./ac. ENM*

*ENM = effective neutralizing material as per State evaluation of quarried rock.

SYNTHETIC FILTER BARRIERS FOR URBAN DEVELOPMENT SITES

APPENDIX D

MAINTENANCE

- Filter barriers shall be inspected immediately after each rainfall and at least daily during prolonged rainfall. Any required repairs shall be made immediately.
- Should the fabric decompose or become ineffective prior to the end of the expected useful life and the barrier still be necessary, longer required shall be dressed to conform with the existing grade, prepared and seeded.
- Sediment deposits should be removed after each storm event. They must be removed when deposits reach approximately half the height of the barrier.
- Any sediment deposits remaining in place after the silt fence or filter barrier is no longer required shall be dressed to conform with the existing grade, prepared and seeded.

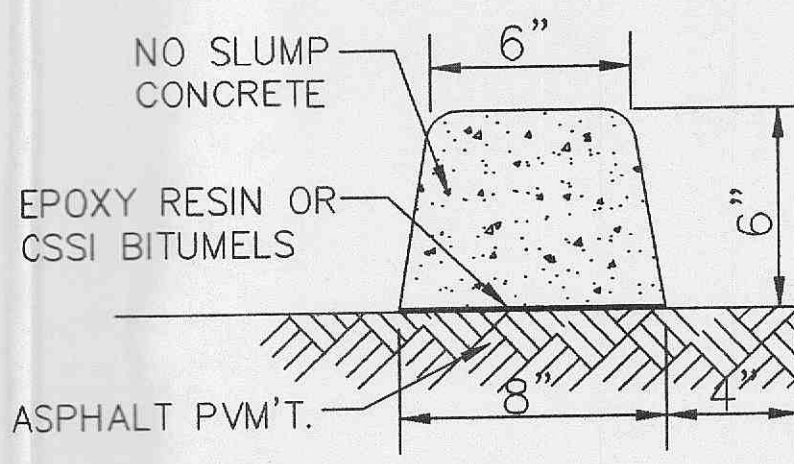
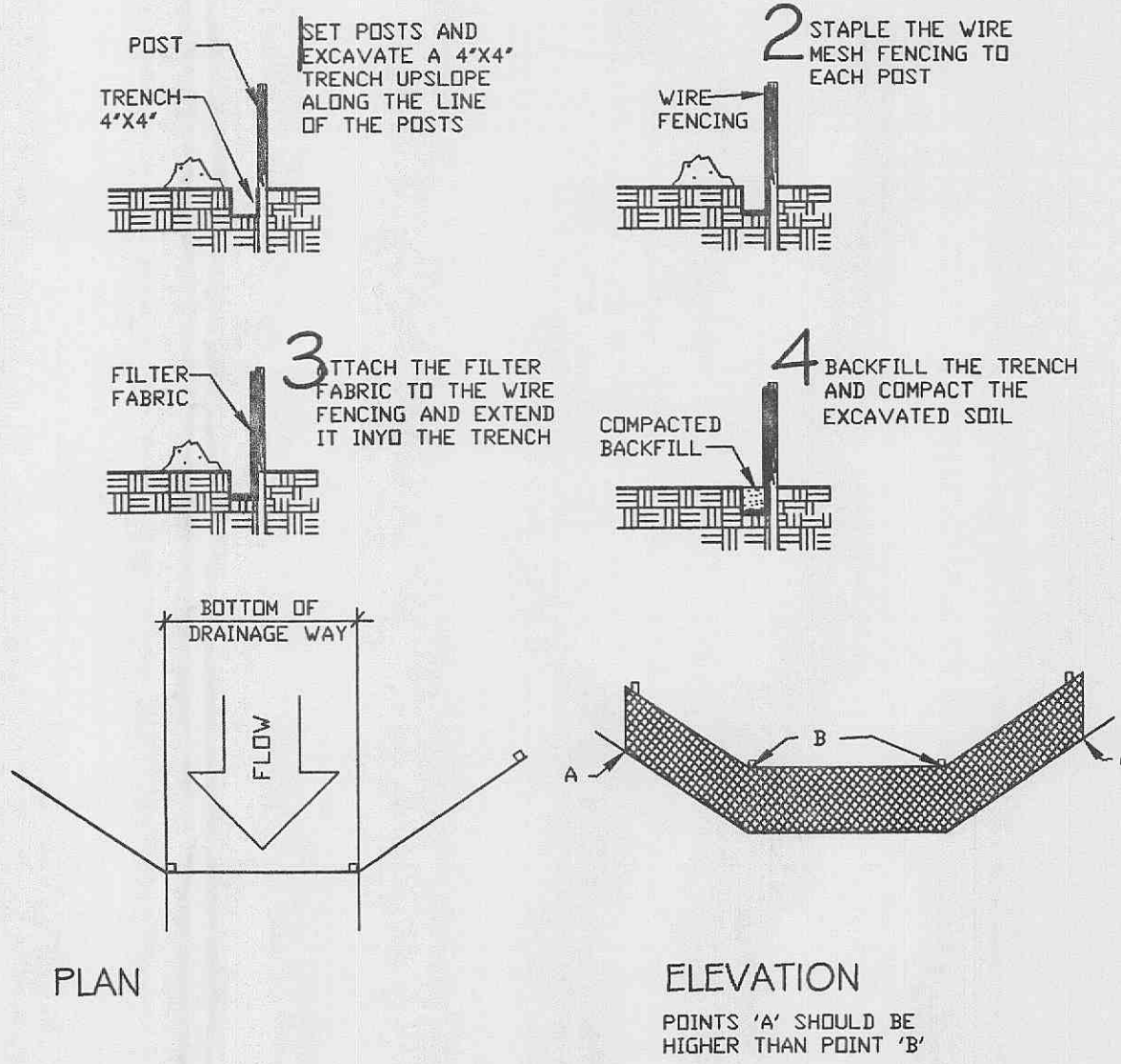

6" EXTRUDED CONCRETE CURB (PERMA-CURB)

NOTE: ALL EROSION CONTROL SYSTEMS ARE INSPECTED AND NECESSARY CORRECTIONS ARE MADE WITHIN 24 HOURS OF ANY RAINSTORM RESULTING IN ONE-HALF INCH OF RAIN OR MORE.

STRAW BALE BARRIERS FOR URBAN DEVELOPMENT SITES

APPENDIX C

