

PLAN OF BEAM

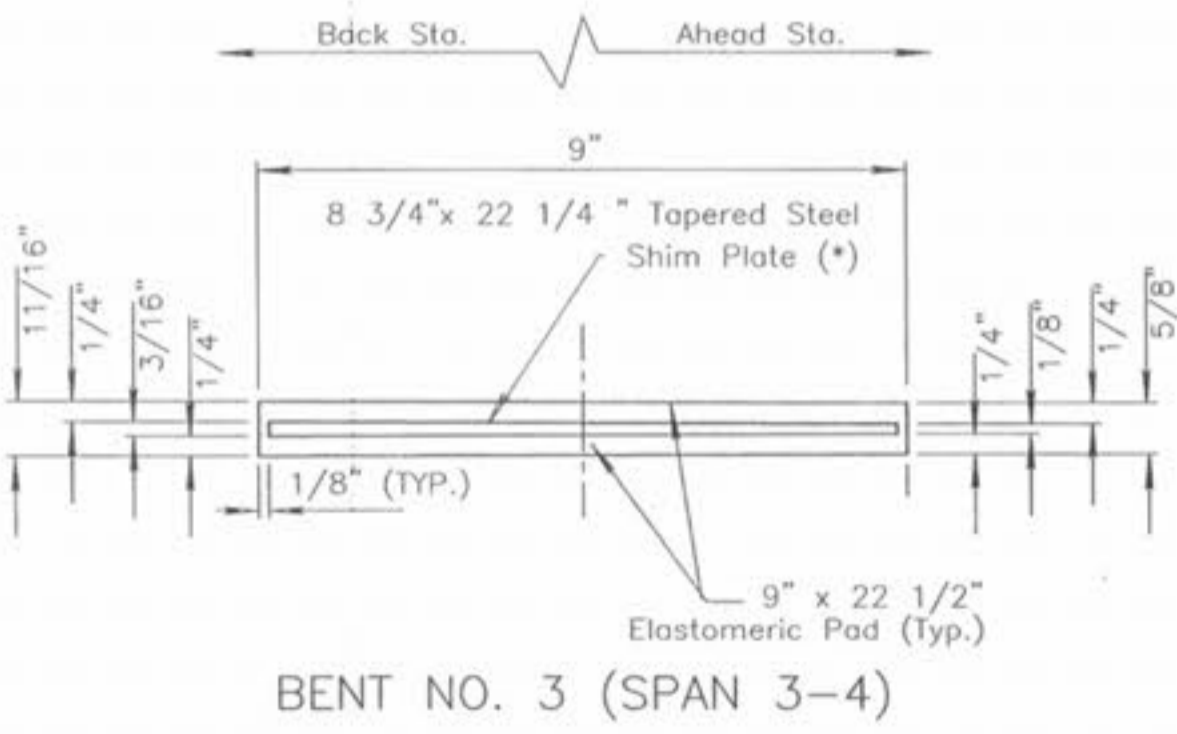

DETAIL OF LAMINATED NEOPRENE BEARING PAD

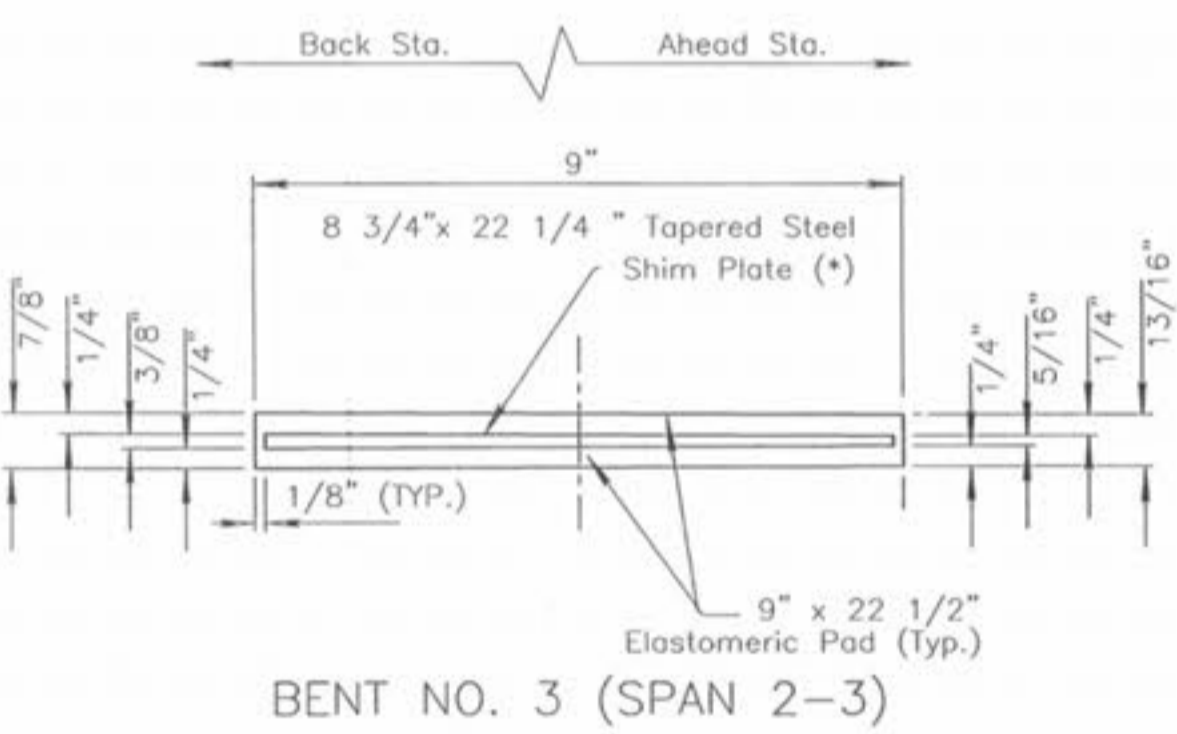
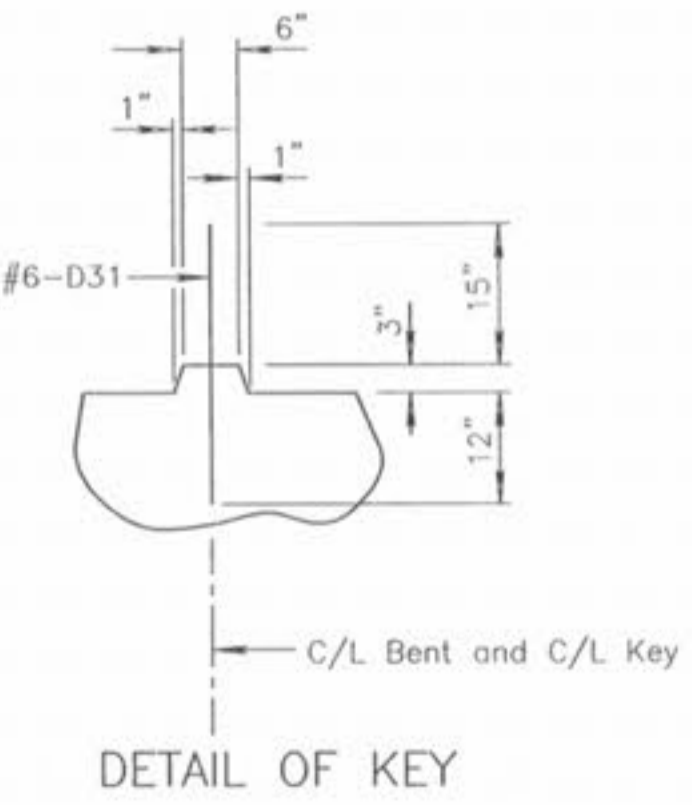

DETAIL OF KEY

ITEM	QUANTITY
Class 1 Excavation	cu. yd. 160
Structural Steel Piles (12 in)	lin. ft. 984
Pile Point Reinforcement	each 24
Class B Concrete (Substr)	cu. yd. 125.6
Reinforcing Steel (Substr)	lbs. 16,489

Note: These quantities are included in the Estimated Quantities table on Sheet No. 3.

ENGINEER'S AUTHENTICATION: The responsibility for professional engineering liability on this project is hereby limited to the set of plans authenticated by the seal, signature and date hereto attached. Responsibility is disclaimed for all other engineering plans involved in this project and specifically excludes revisions after this date, unless reauthenticated.



DETAILS INTERMEDIATE BENT NO. 3

NOTE: This drawing is not to scale. Follow dimensions.