

TYPICAL ADA RAMP AT ENTRY TO APARTMENTS

NOT TO SCALE

1. AT NO TIME CAN A RAMP EXCEED A 1:12 OR 8.33% SLOPE.
2. CONTRACTOR TO BE AWARE THAT MAXIMUM ALLOWABLE CROSS SLOPE ON NEW PAVEMENT IS 2% MAXIMUM RUNNING SLOPE ON NEW PAVEMENT (OTHER THAN RAMPS) IS 5%.
3. CONTRACTOR TO VERIFY GRADES AND SLOPES PRIOR TO INSTALLING CONCRETE.

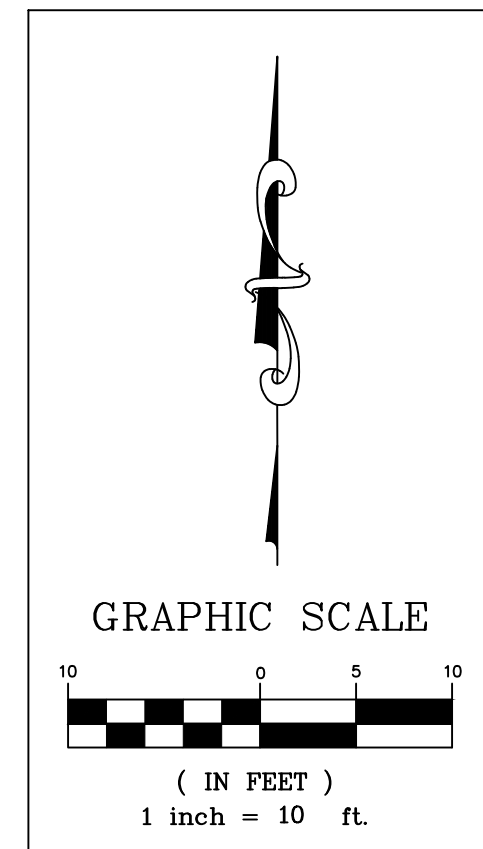
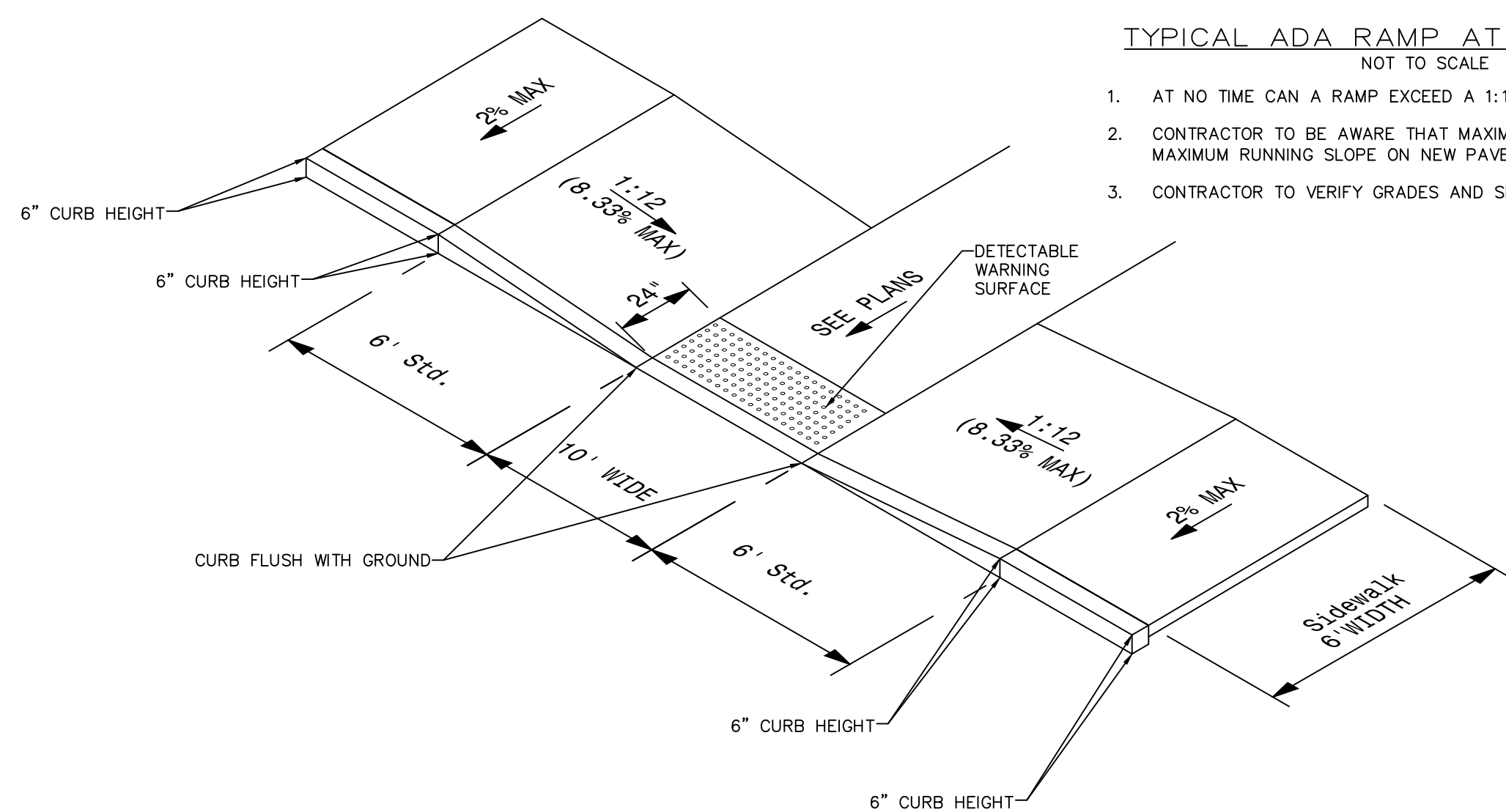

**DOG PARK
5,066 S.F.**

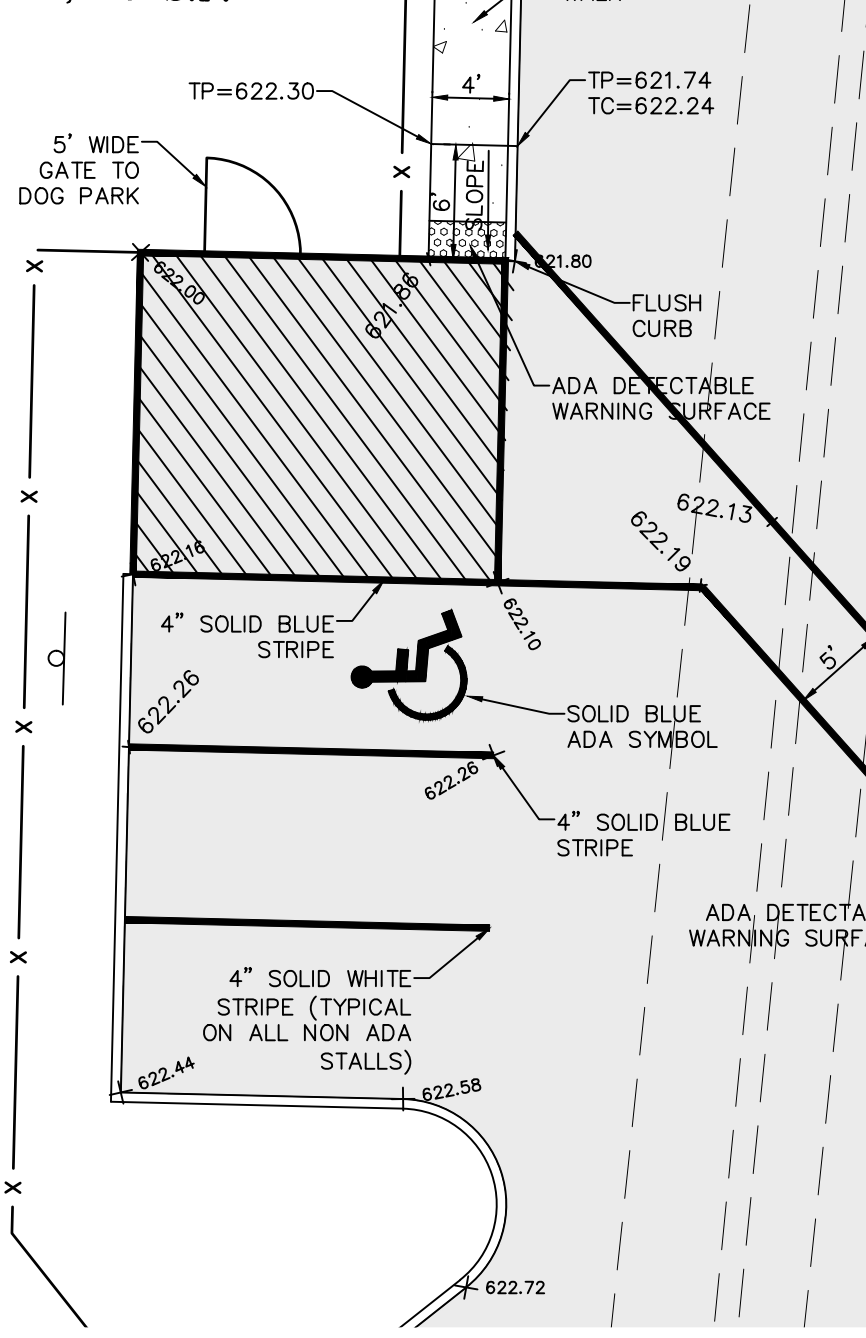

TYPICAL ADA RAMP AT NORTH WEST CORNER OF BLDG #1

NOT TO SCALE

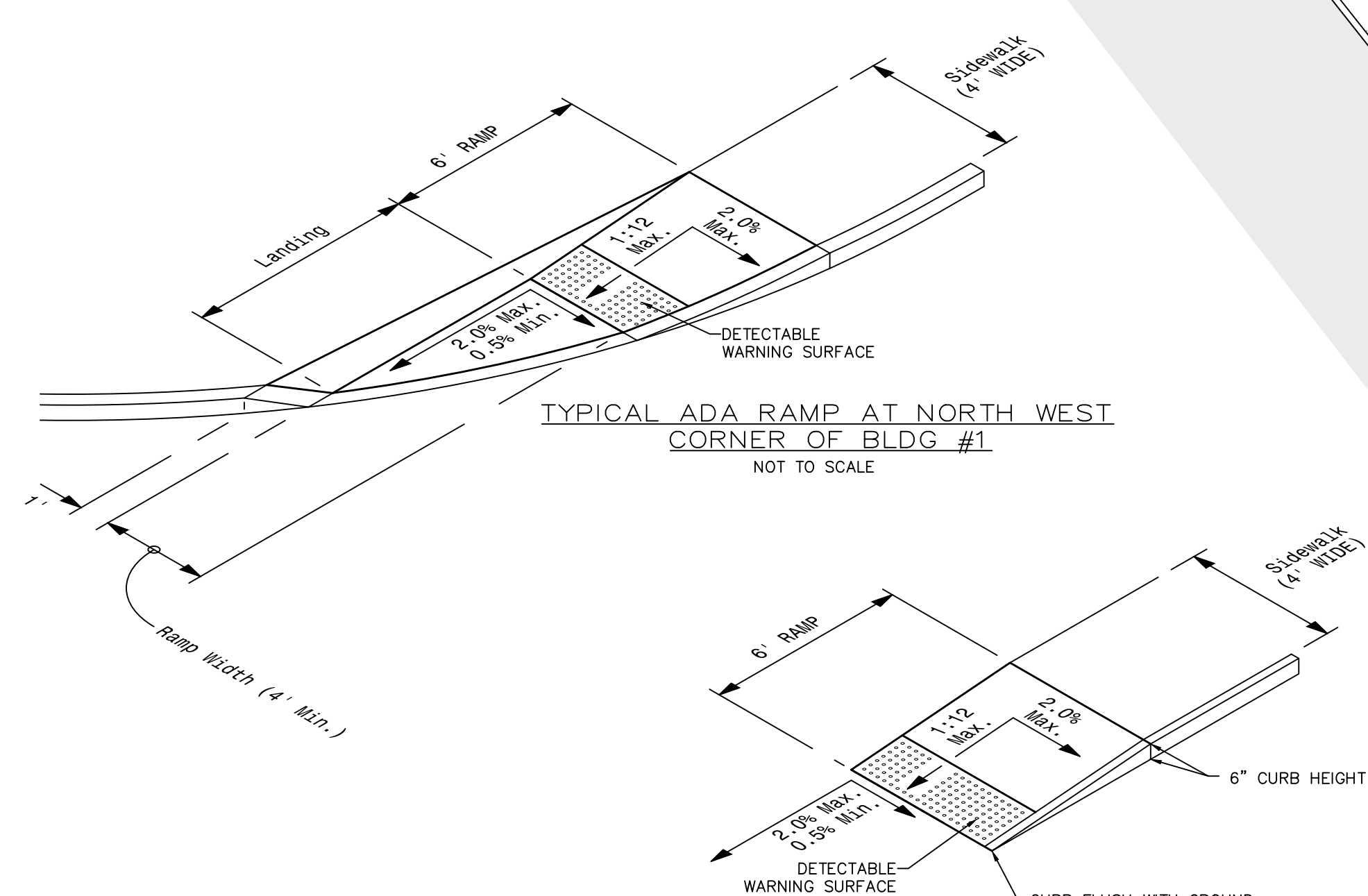

TYPICAL ADA RAMP AT DOG PARK

NOT TO SCALE

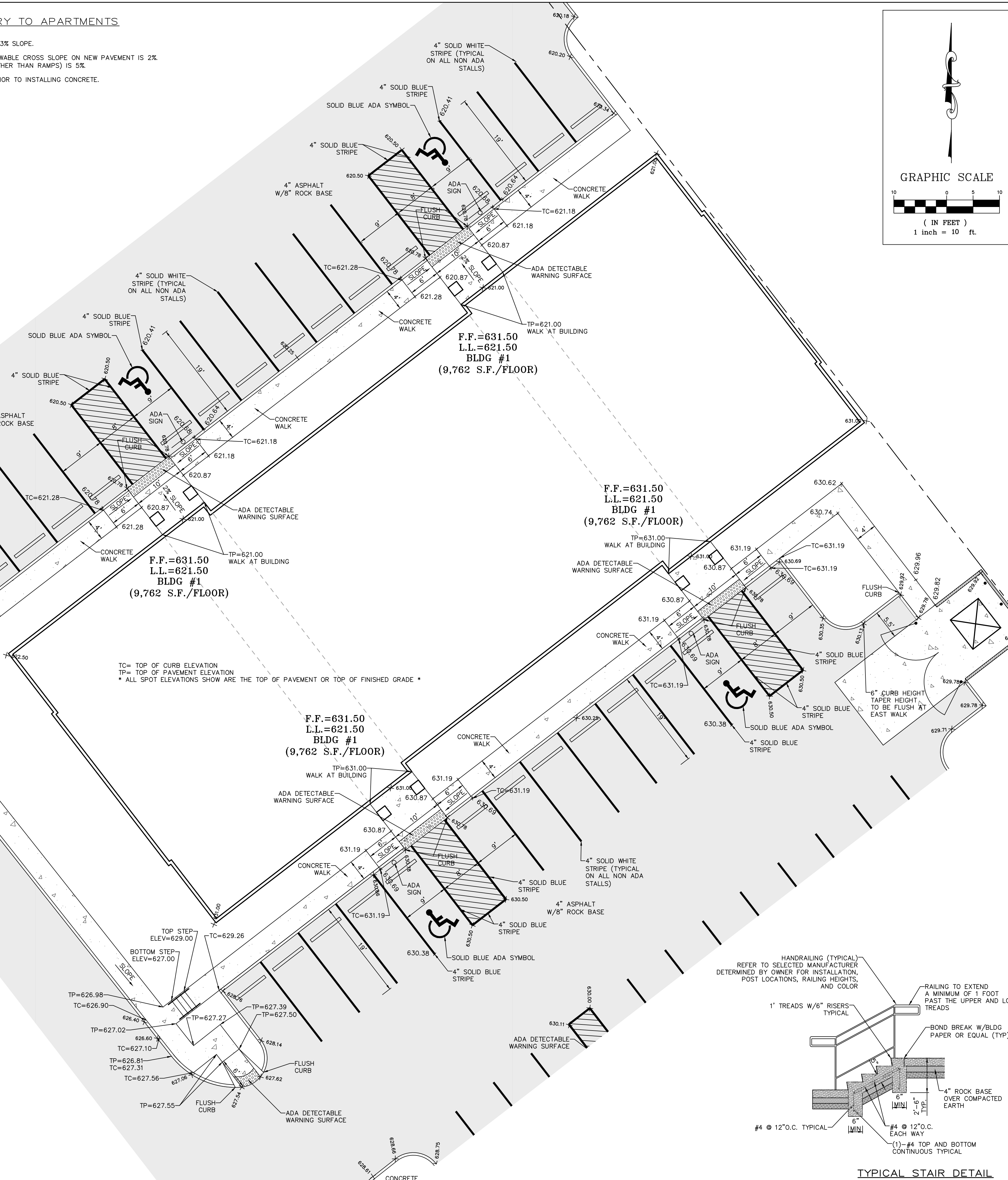

TC= TOP OF CURB ELEVATION
TP= TOP OF PAVEMENT ELEVATION
* ALL SPOT ELEVATIONS SHOW ARE THE TOP OF PAVEMENT OR TOP OF FINISHED GRADE *

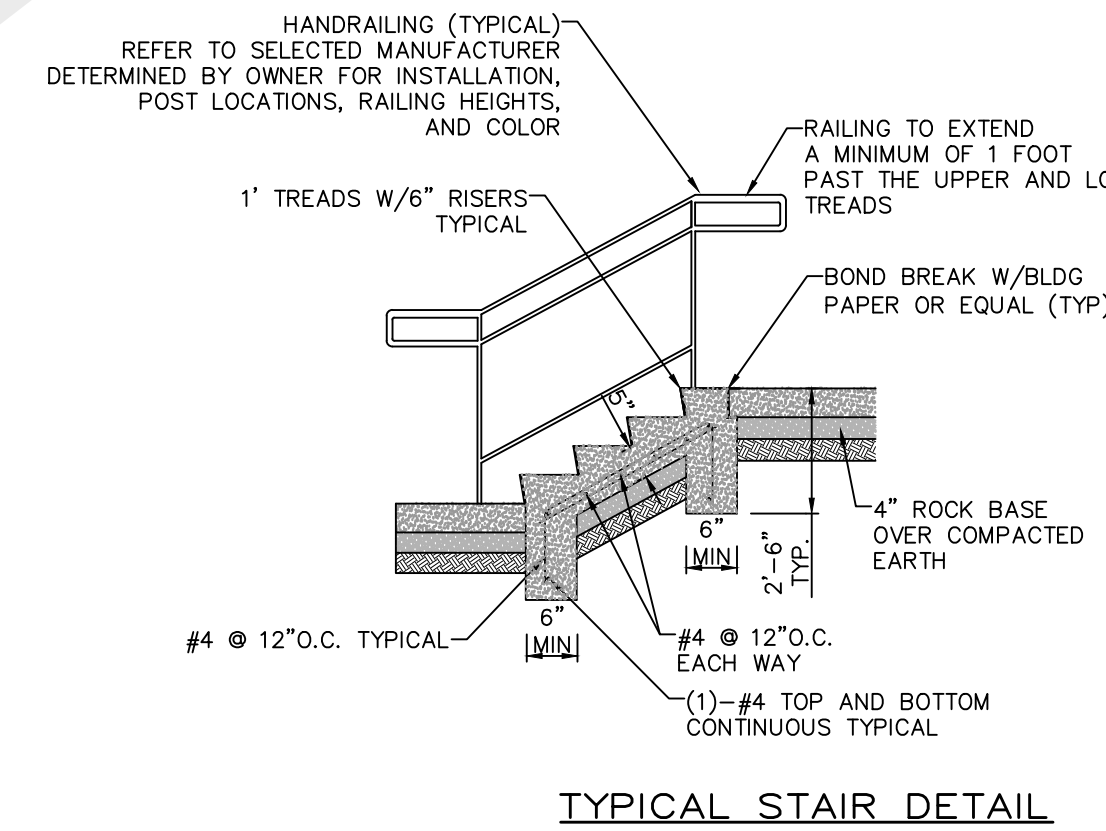

TYPICAL STAIR DETAIL
NOT TO SCALE

PROJECT TITLE:
THORNWOOD APARTMENTS
THORNBURY CROSSING DRIVE
OFALLON, MO 63366

**ENGINEERING
PLANNING
SURVEYING**
221 Point West Blvd.
St. Charles, MO 63301
636-928-5552
FAX 636-928-1718

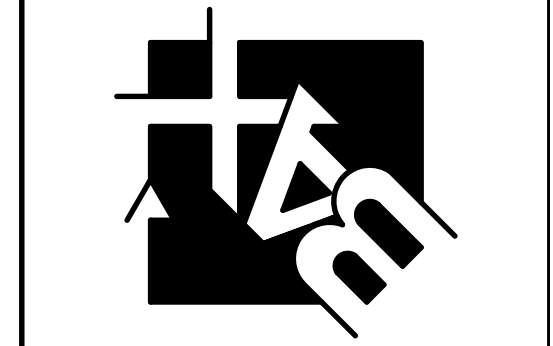

DISCLAIMER OF RESPONSIBILITY
I hereby certify that the documents intended to be authenticated by my seal are limited to this sheet, and I hereby disclaim any responsibility for all other drawings, specifications, estimates, reports or other documents or instruments relating to or intended to be used for any part or parts of the architectural or engineering project or survey.

STATE OF MISSOURI
CLIFFORD L. HEITMANN
NUMBER E-29817
REGISTERED PROFESSIONAL ENGINEER
10/24/24
CLIFFORD L. HEITMANN
Civil Engineer
Engineers License E-29817

REVISIONS

07-25-24	CITY COMMENTS
08-15-24	CITY COMMENTS

Bax Engineering Company, Inc.
Missouri State Certificate of Authority
Engineering #000655
Missouri State Certificate of Authority
Surveying #000144

Developer / Owner:
MRS TROMBONE LLC
1100 WOODCHASE LANE
CHESTERFIELD, MO 6307
314-469-0029

P+Z No. 23-010426
Approval Date: 1-4-24
City No. #

Page No.
16 of 34

I:\VAULT\SERVER\Civil\3d Projects\19014\Construction\19014\Constsheets.dwg, ARCH full bleed D (24.00 x 36.00 inches), 1:1