

PROPERTY N/F
KAPLAN DEVELOPMENT
INVESTMENT CO.
2376/1858
I-1 LIGHT INDUSTRIAL

PROPERTY N/F
MICHAEL GRECO
1488/1492
I-1 LIGHT INDUSTRIAL

SITE PLAN
**VATTEROTT COLLEGE
PARKING ADDITION**

95-641E
Per City Comments
Per Client Changes

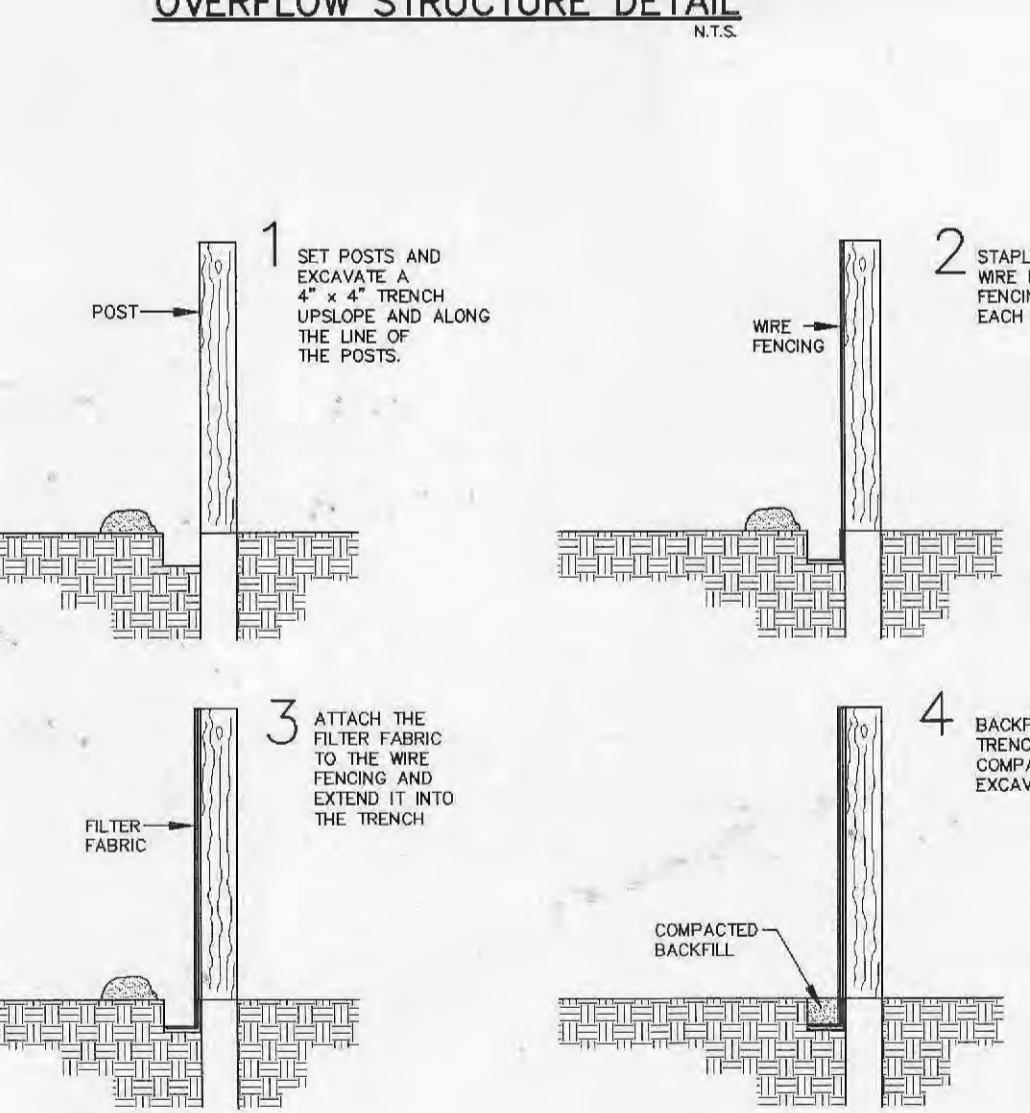
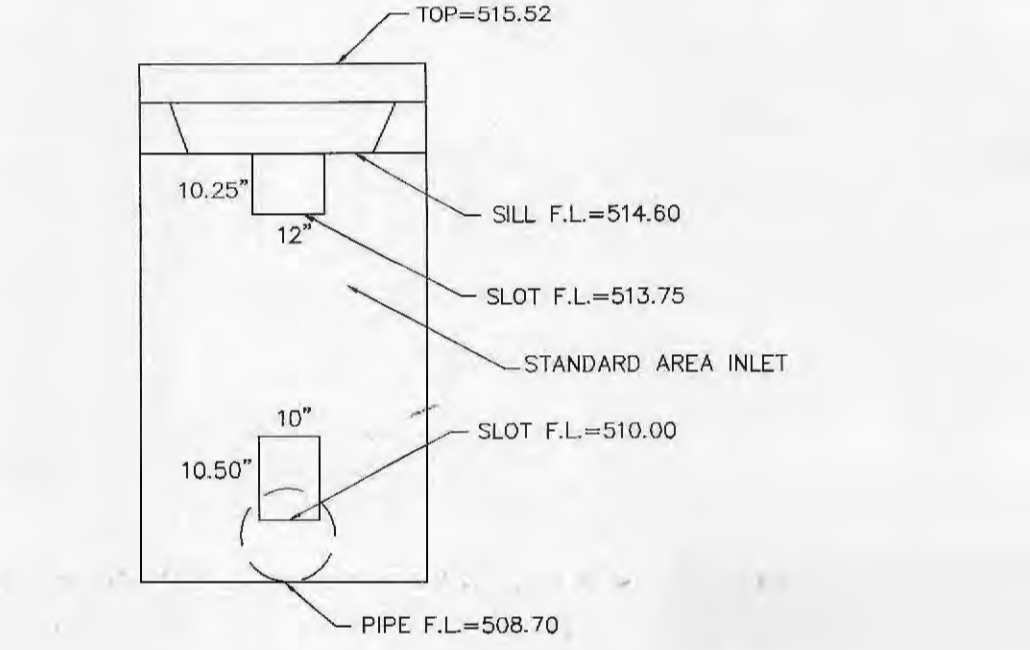
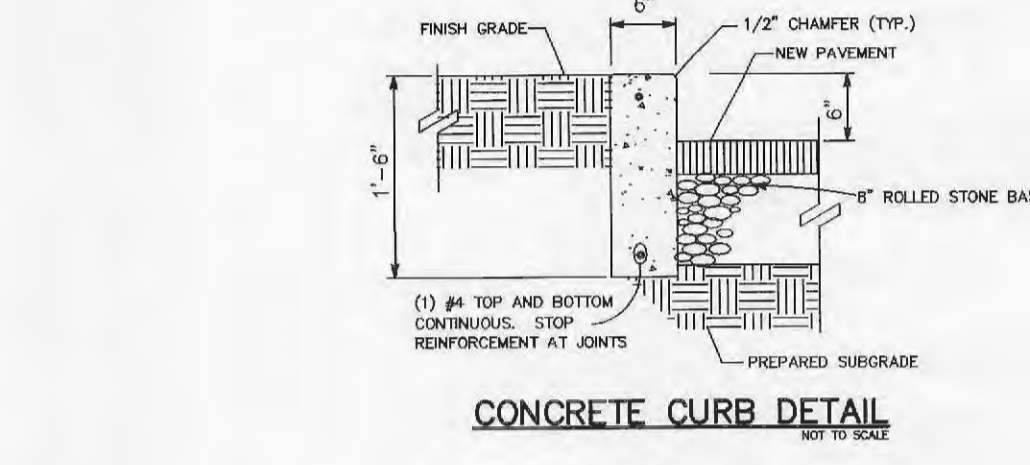
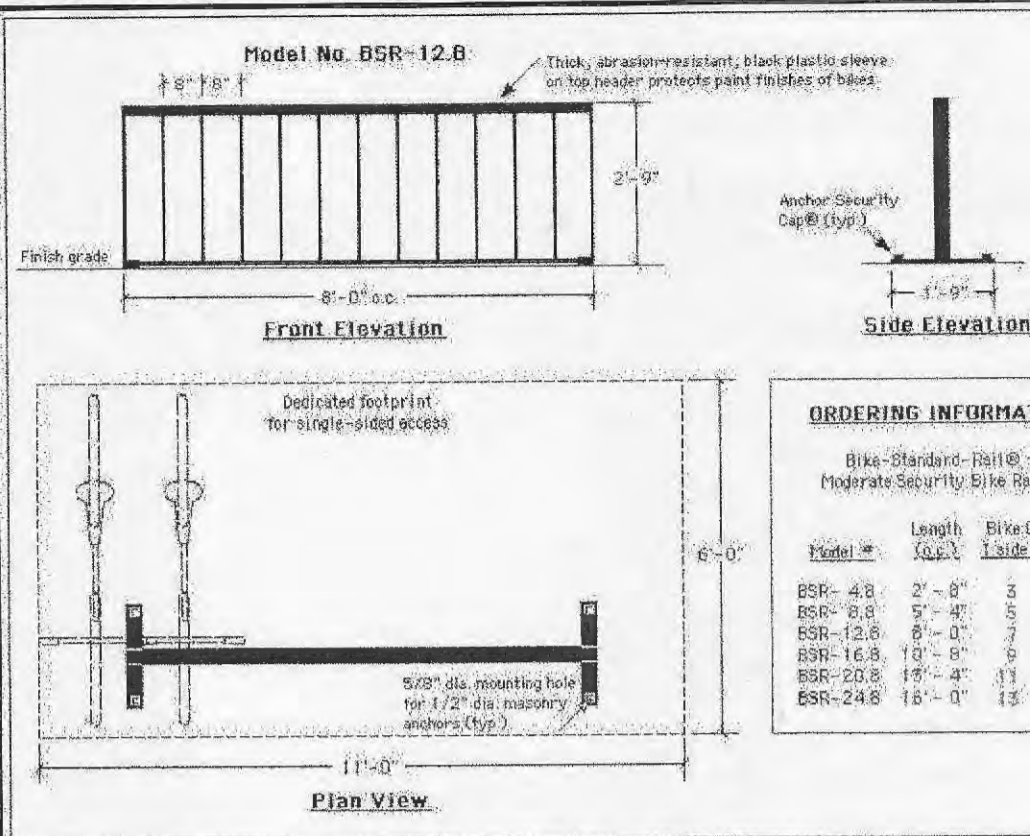
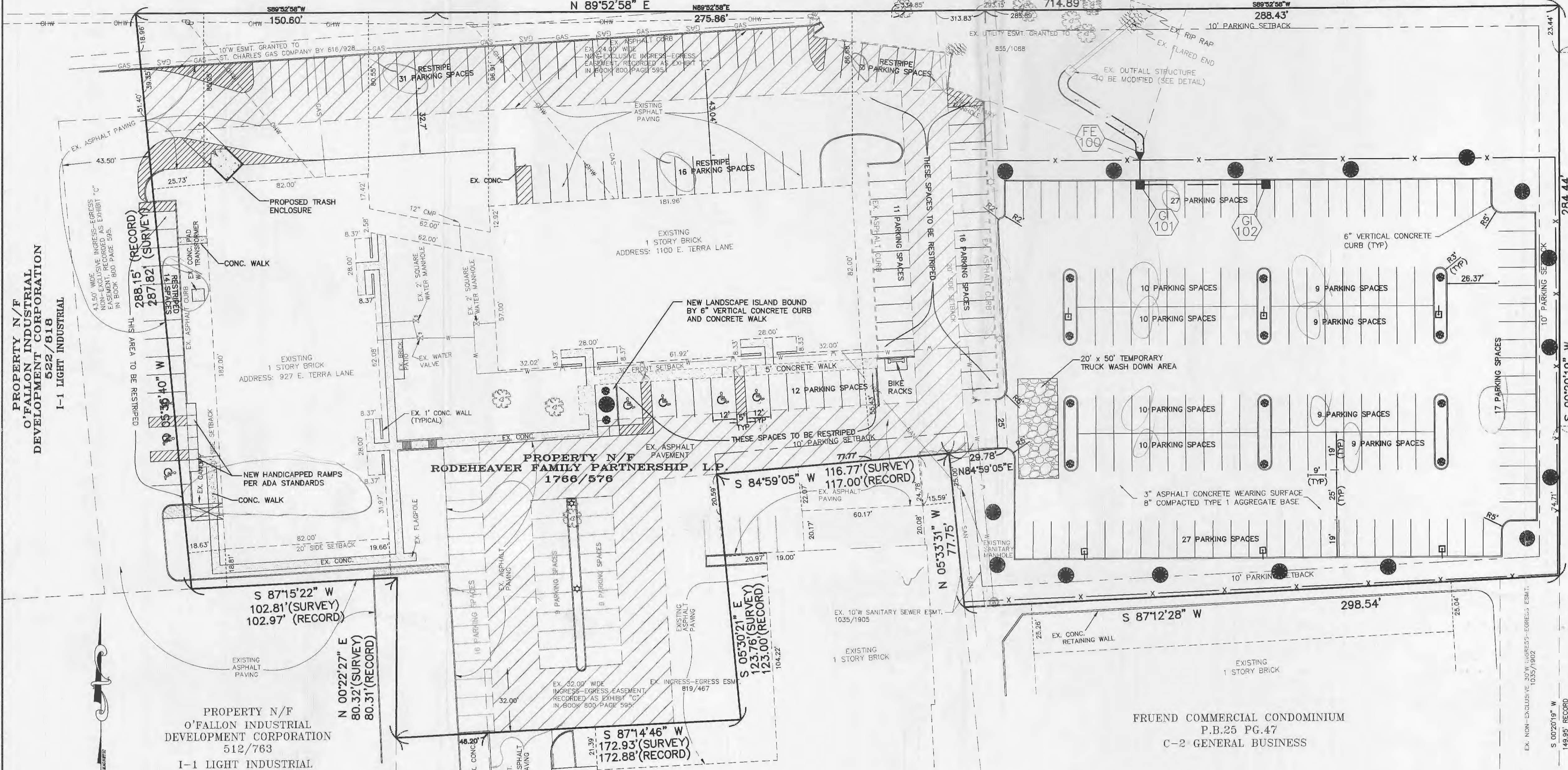

1. FILTER BARRIERS SHALL BE INSPECTED IMMEDIATELY AFTER EACH RAINFALL AND AT LEAST DAILY DURING PROLONGED ANY REQUIRED REPAIRS SHALL BE MADE IMMEDIATELY.
2. SHOULD THE FABRIC DECOMPOSE OR BECOME INEFFECTIVE PRIOR TO THE END OF THE EXPECTED USABLE LIFE AND IT STILL BE NECESSARY, THE FABRIC SHALL BE REPLACED PROMPTLY.
3. SEDIMENT DEPOSITS SHOULD BE REMOVED AFTER EACH STORM EVENT, THEY MUST BE REMOVED WHEN DEPOSITS REACH APPROXIMATELY HALF THE HEIGHT OF THE BARRIER.
4. ANY SEDIMENT DEPOSITS REMAINING IN PLACE AFTER THE SILT FENCE OR FILTER BARRIER IS NO LONGER REQUIRED MUST BE DRESSED TO CONFORM WITH THE EXISTING GRADE, PREPARED AND SEED.



NOTE: TO BE USED AT INTAKE AND DISCHARGE END OF PIPE. GRADE OF ROCK BLANKET TO BE ADJUSTED ACCORDINGLY.
GROUTED ROCK BLANKET REQUIRED.

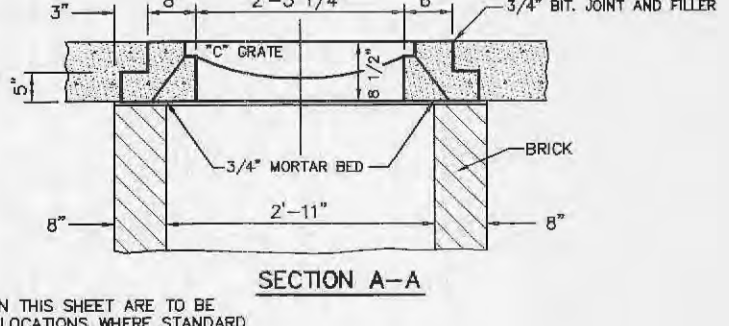
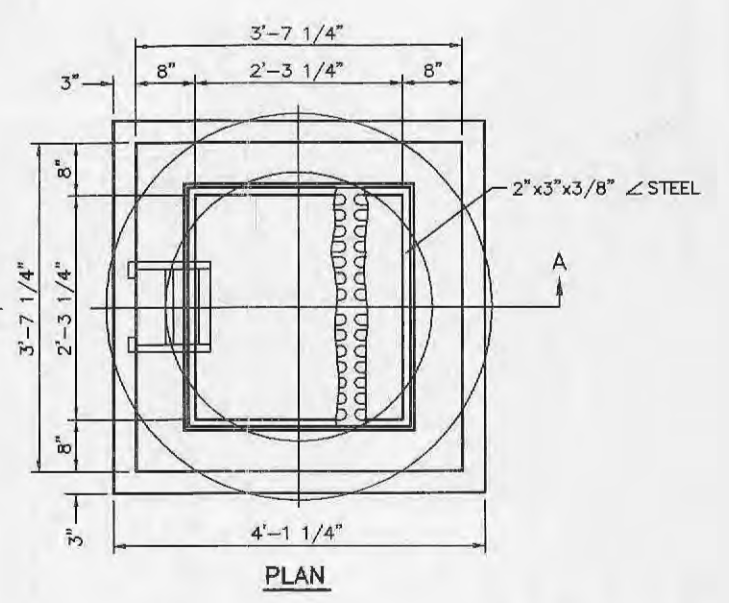
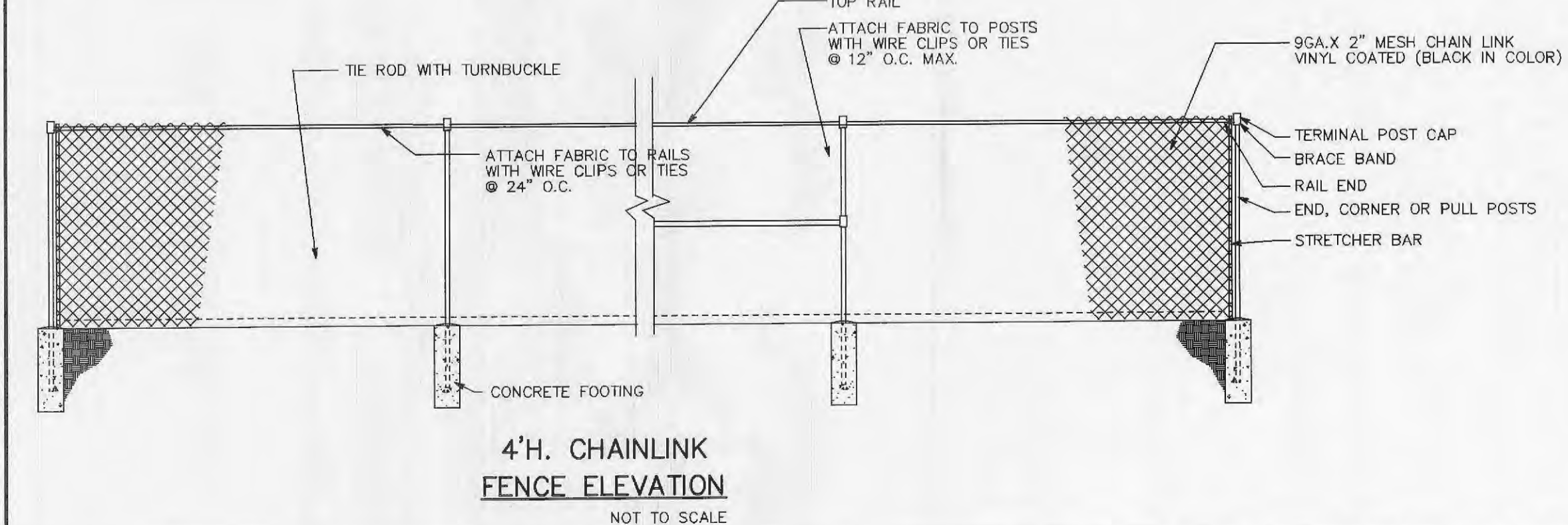
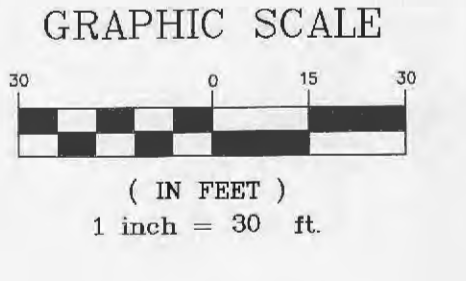

NOTE: INLETS ON THIS SHEET ARE TO BE USED IN LOCATIONS WHERE STANDARD OVER THE ROAD INLETS CAN NOT BE USED, IN PAVED TRAFFIC WAY, AND IN LIMITED EASEMENTS.

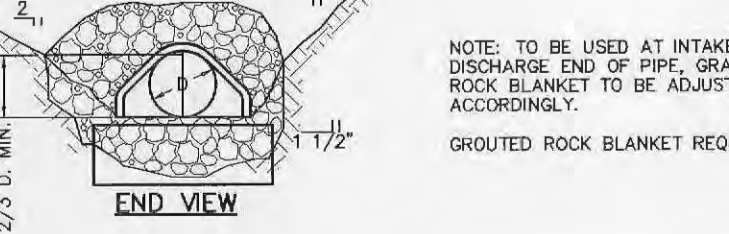
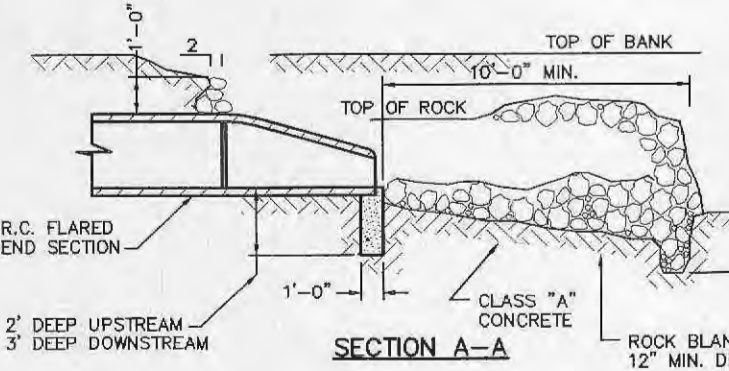
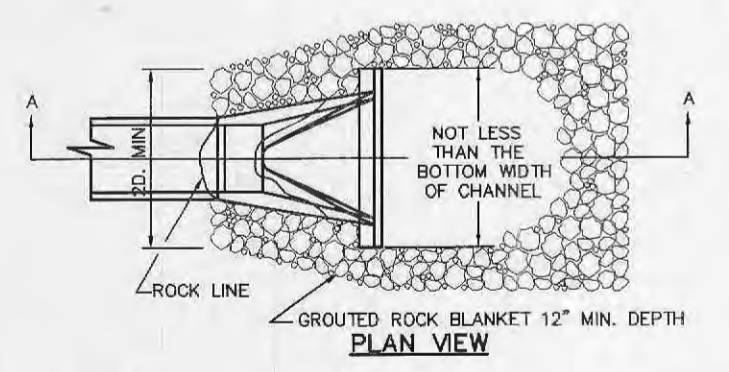

NOTE: TO BE USED AT INTAKE AND DISCHARGE END OF PIPE. GRADE OF ROCK BLANKET TO BE ADJUSTED ACCORDINGLY.
GROUTED ROCK BLANKET REQUIRED.

UNDERGROUND UTILITIES HAVE BEEN PLOTTED FROM AVAILABLE INFORMATION AND THEREFORE THEIR LOCATIONS SHALL BE CONSIDERED APPROXIMATE ONLY. THE VERIFICATION OF THE LOCATION OF ALL UNDERGROUND UTILITIES, EITHER SHOWN OR NOT SHOWN ON THESE PLANS SHALL BE THE RESPONSIBILITY OF THE CONTRACTOR, AND SHALL BE LOCATED PRIOR TO ANY GRADING OR CONSTRUCTION OF THE IMPROVEMENTS.

E:\DWG\6000PLUS\6411E\CONSTRUCTION\6411ECON.dwg, SITE PLAN(3), 3/24/2004 8:17:15 AM, STATION 35 KW