

SAINT CHARLES COUNTY HIGHWAY DEPARTMENT ST. CHARLES, MISSOURI	
GUARDRAIL END ANCHOR DETAILS	
DATE: December, 2000	DRAWING C606.05

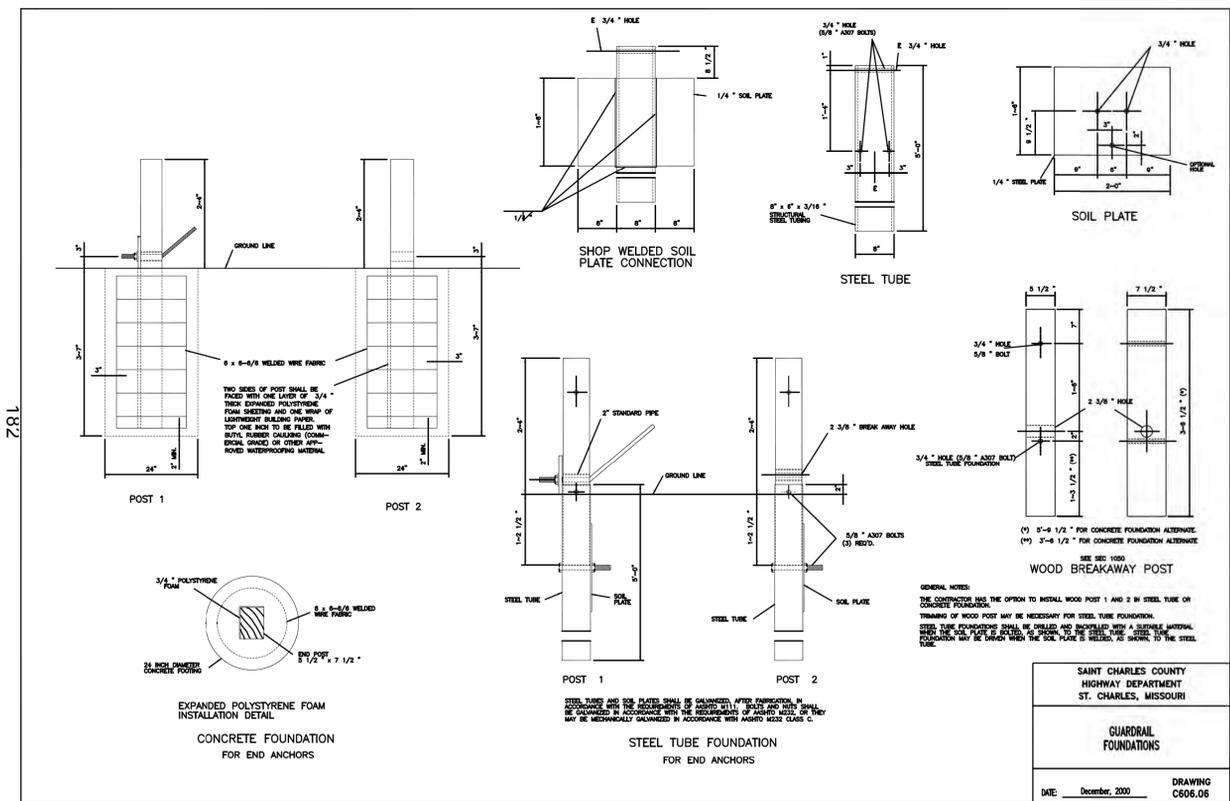

SAINT CHARLES COUNTY HIGHWAY DEPARTMENT ST. CHARLES, MISSOURI	
GUARDRAIL FOUNDATIONS	
DATE: December, 2000	DRAWING C606.06

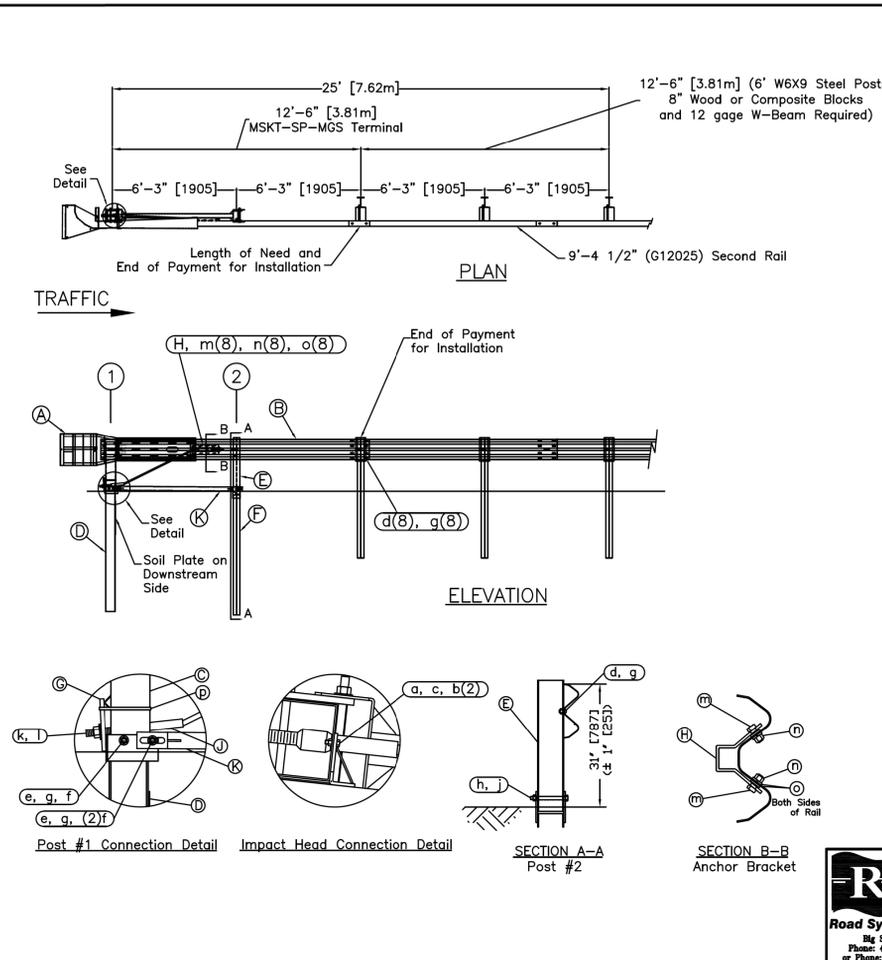

ITEM	QTY	BILL OF MATERIALS	ITEM NO.
A	1	IMPACT HEAD	MS3000
B	1	W-BEAM GUARDRAIL END SECTION, 12 Ga.	SF1303
C	1	FIRST POST TOP (6x6x4" Tube)	MTHP1A
D	1	FIRST POST BOTTOM (6" W6X15)	MTHP1B
E	1	SECOND POST ASSEMBLY TOP	LHP2A
F	1	SECOND POST ASSEMBLY BOTTOM	HP2B
G	1	BEARING PLATE	E750
H	1	CABLE ANCHOR BOX	S760
J	1	BCT CABLE ANCHOR ASSEMBLY	E770
K	1	STRUT	MS785
HARDWARE (ALL DIMENSIONS IN INCHES)			
a	2	5/16 x 1 HEX BOLT GRD 5	B5160104A
b	4	5/16 WASHER	W0516
c	2	5/16 HEX NUT	N0516
d	8	5/8 Dia. x 1 1/4 SPLICE BOLT (POST #2)	S550122
e	2	5/8 Dia. x 9 HEX BOLT GRD 5	B550304A
f	3	5/8 WASHER	W050
g	11	5/8 Dia. H.G.R. NUT	N050
h	1	3/4 Dia. x 8 1/2 HEX BOLT GRD A440	B340854A
j	1	3/4 Dia. HEX NUT	N030
k	2	1 ANCHOR CABLE HEX NUT	N100
l	2	1 ANCHOR CABLE WASHER	W100
m	8	1/2 RSI SHOULDER BOLT W/WASHER	SB12A
n	8	1/2 STRUCTURAL NUT	N012A
o	8	1/2 STRUCTURAL WASHER	W012A
p	1	BEARING PLATE RETAINER TIE	CT-1005T

GENERAL NOTES:

- All bolts, nuts, cable assemblies, cable anchors and bearing plates shall be galvanized.
- The lower sections of the Posts 1&2 shall not protrude more than 4 in [100] above the ground (measured along a 5' [1.5m] cord). Site grading may be necessary to meet this requirement.
- The lower section of the hinged post should not be driven with the upper post attached. If the post is placed in a drilled hole, the backfill material must be satisfactorily compacted to prevent settlement.
- When competent rock is encountered, a 12" [300] Ø post hole, 20 in. [500] deep cored into the rock surface may be used if approved by the engineer for Posts 1 and/or 2. Granular material will be placed in the bottom of the hole, approximately 2.5' [60] deep to provide drainage. The first and/or second post can be field cut to length, placed in the hole and backfilled with suitable backfill. The soil plate may be trimmed if required.
- The breakaway cable assembly must be taut. A locking device (vice grips or channel lock pliers) should be used to prevent the cable from twisting when tightening nuts.

	MSKT-SP-MGS Terminal Test Level 2	Sheet: 1
	Drawing Name: MSKT-SP-MGS-TL2 Scale: None Rev: 0	Date: 07/30/16 By: JRR



Lombardo
H · O · M · E · S

4 Research Park Drive, Suite 130
St. Charles, MO 63304
Phone: (636) 265-2710

VOLZ
INCORPORATED

10849 Indian Head Indl. Blvd.
St. Louis, Missouri 63132
314.890.1250 Fax
www.volzinc.com
Aulinity #203

RYAN L. HOLMES
Professional Engineer
PE-2017018988

THE VILLAS AT ARAGON
VETERANS MEMORIAL PARKWAY
OF FALLON, MO 63366

CONSTRUCTION DETAILS: SHEET 9

Design By: R/LH
Drawn By: R/LH
Checked By: R/LH

Permit No. GR22-00001
Volz Project # 22649

10-12-22
C22.8