

18" Dia. Pipe Requires A 48" Dia. Manhole

PRE-CAST CONCRETE MANHOLE FOR SEWERS 8' THRU 18'

SCALE : N.T.S.

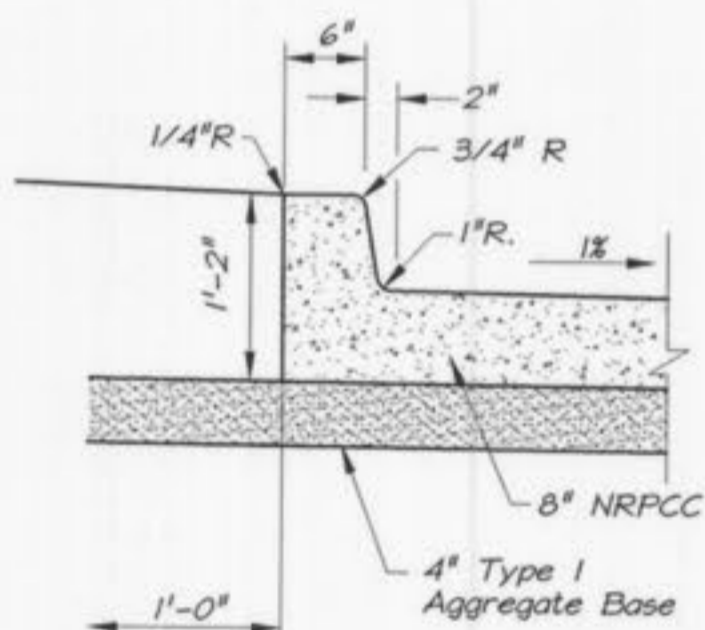

NOTES:
 1. Contraction Joints Placed Every 20'

CONCRETE CURB DETAIL WITHIN PARKING LOTS

SCALE : N.T.S.

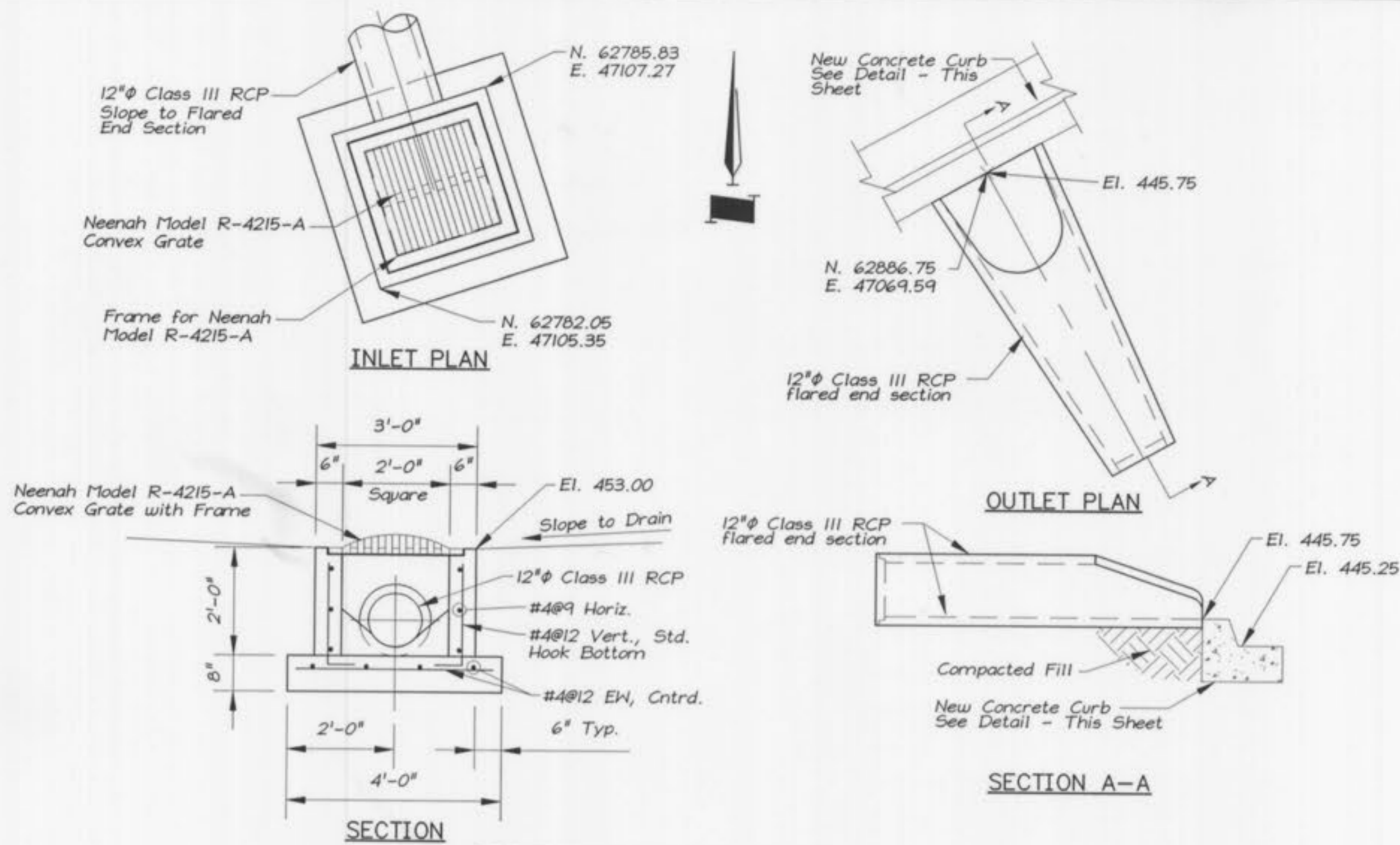

YARD DRAIN DETAILS

SCALE : 1/4" = 1'-0"

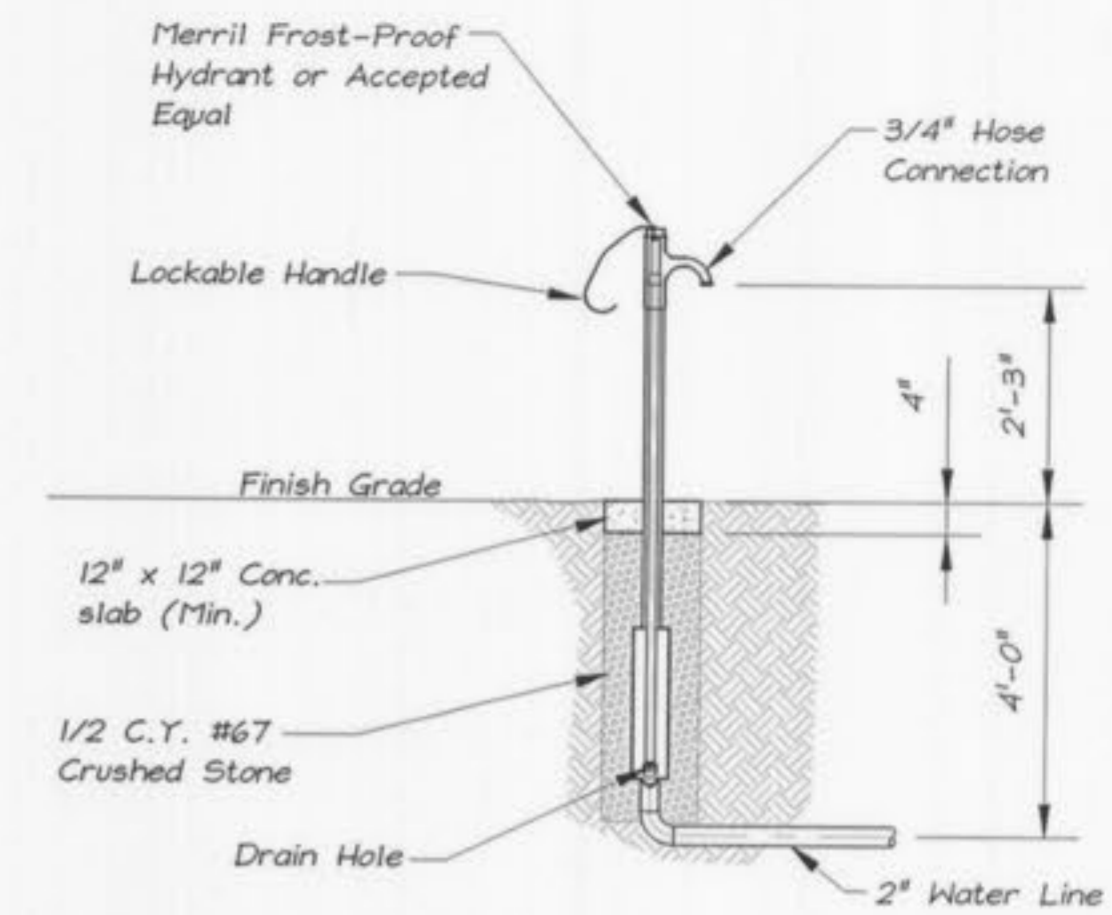

YARD HYDRANT

SCALE : N.T.S.

PIPE SIZE	FITTING					DEAD END
	11 1/4" BEND	22 1/2" BEND	45" BEND	90" BEND	TEE	
4"	1.0	2.5	4.5	8.0	5.5	5.5
8"	2.0	4.0	7.5	14.0	10.0	10.0
10"	2.5	5.0	9.0	22.0	16.0	16.0
12"	4.0	8.0	16.0	29.0	20.5	20.5
20"	13.0	20.0	36.0	45.0	45.0	45.0
24"	18.0	24.0	42.0	58.0	52.0	52.0
30"	20.0	26.0	44.0	60.0	54.0	54.0

MINIMUM BEARING AREAS ARE BASED ON SOIL WITH AN ALLOWABLE LATERAL BEARING PRESSURE OF 2000 PSF. REVISE BEARING AREA FOR SOIL WITH A LESSER ALLOWABLE BEARING PRESSURE.

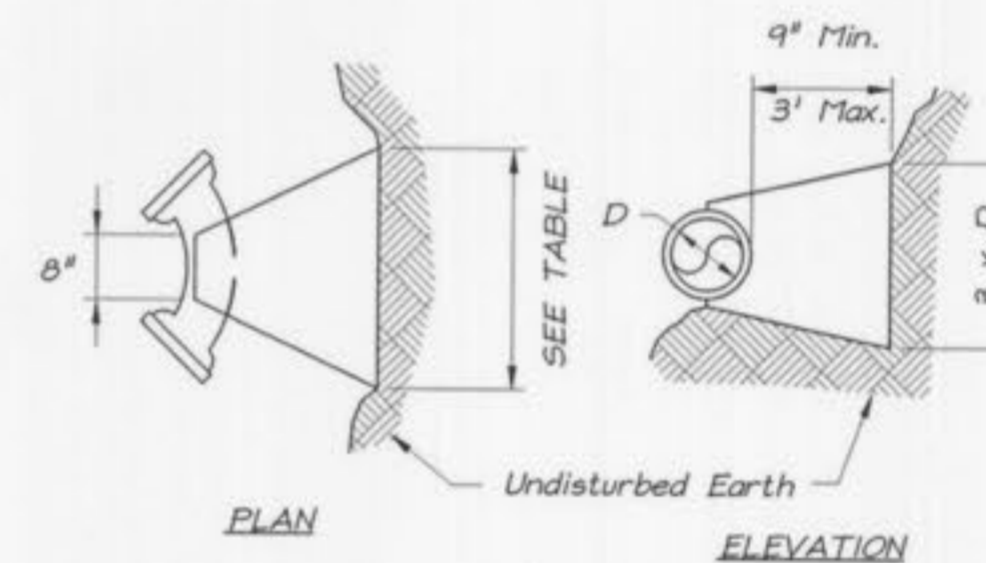

FORCE MAIN FITTING THRUST BLOCK DETAILS

SCALE : N.T.S.

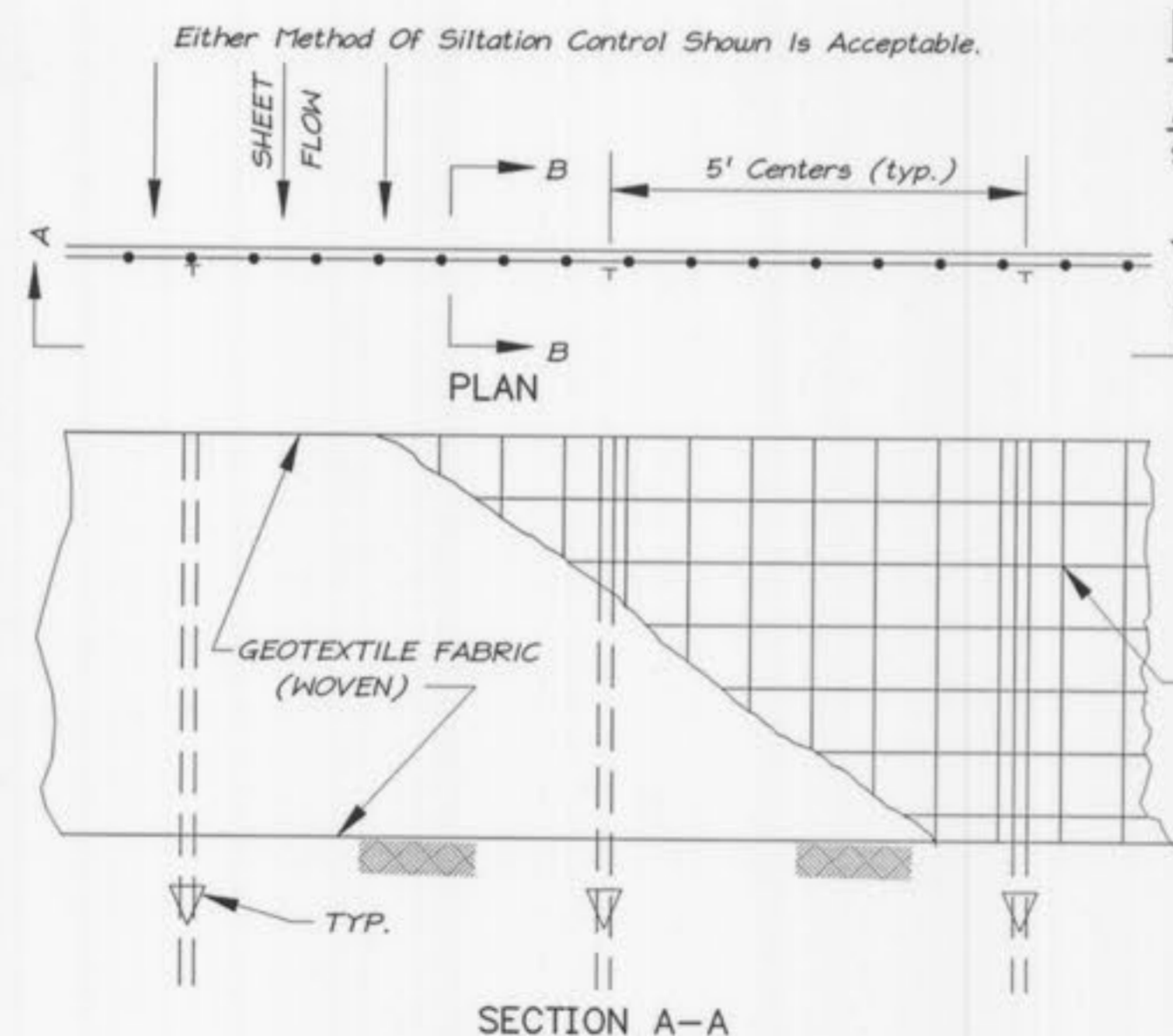

SILTATION FENCE DETAILS

EXISTING AIR/VACUUM VALVE AND VAULT MODIFICATIONS

SCALE : N.T.S.

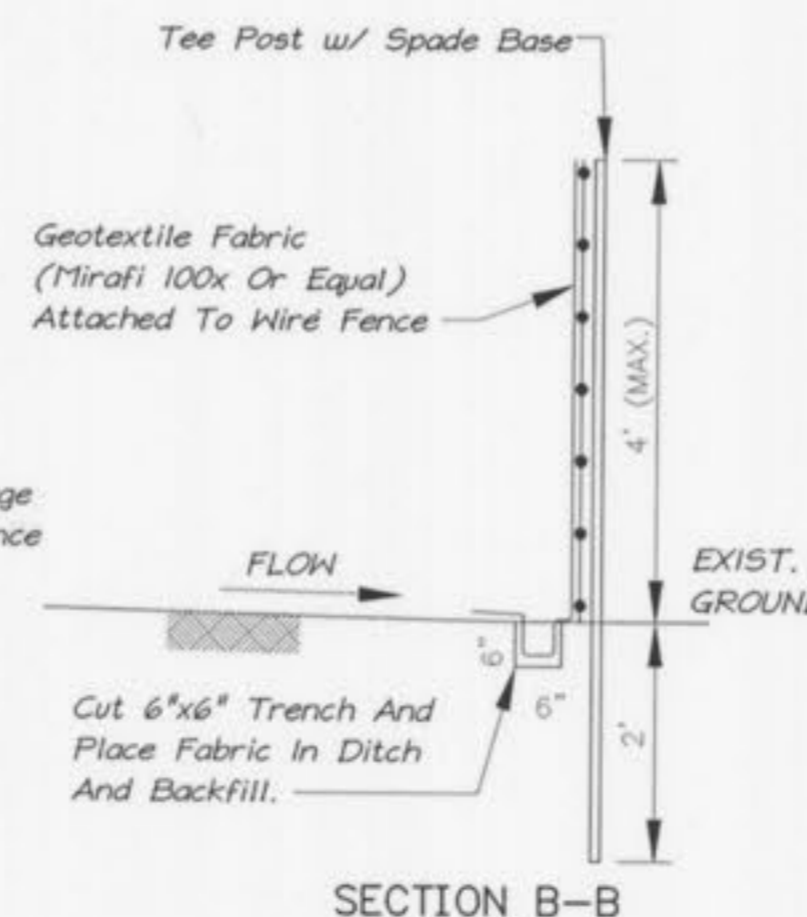

SILTATION CONTROL DEVICES

SCALE : N.T.S.

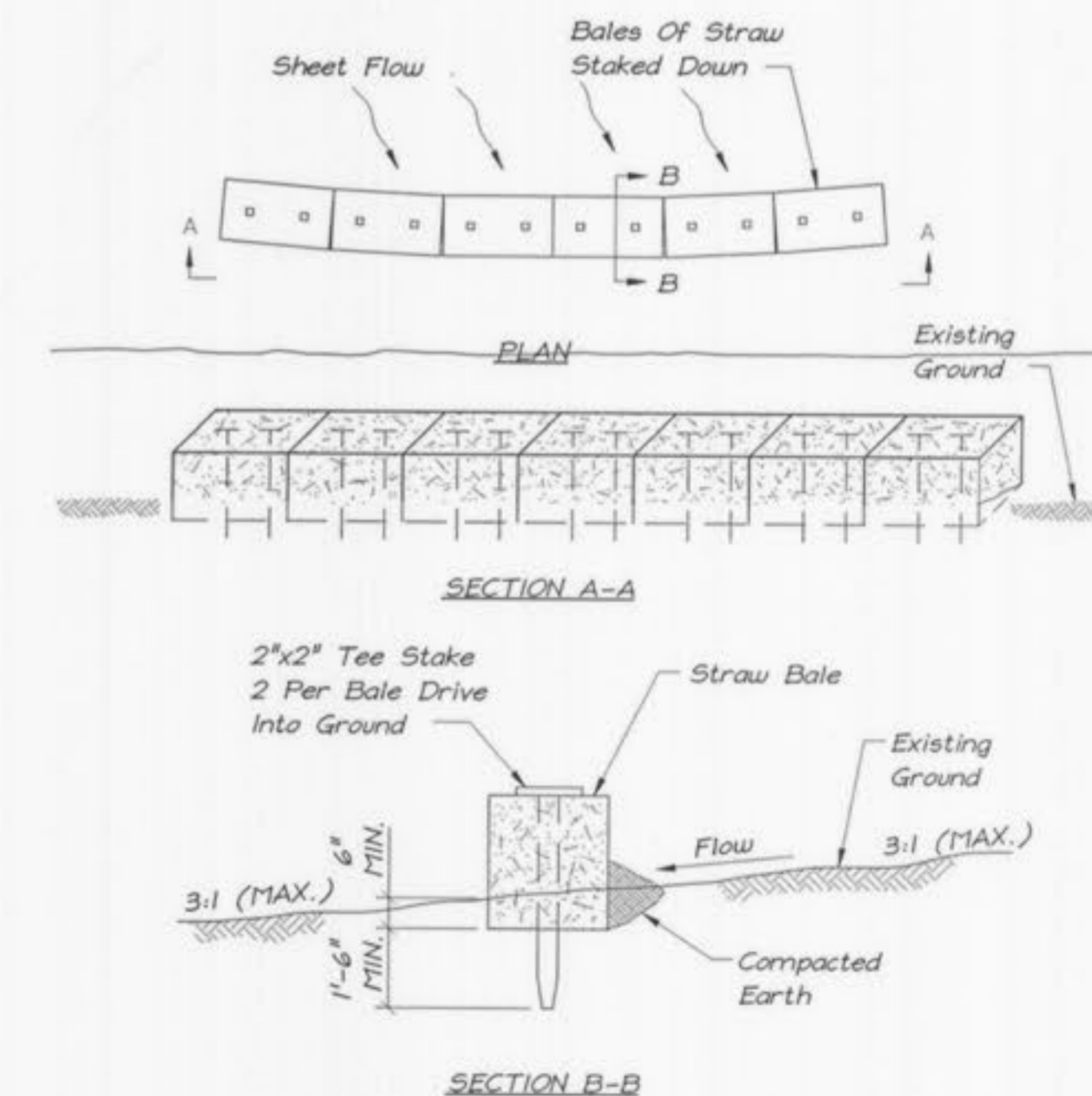

STRAW BALE DETAIL

GEORGE BUTLER ASSOCIATES, INC.
 Engineers • Architects
 Kansas • Missouri • Illinois

GBA

STATE OF MISSOURI
 ROBERT J. RUSSIN
 NUMBER E-2000
 10/10/11

WASTEWATER TREATMENT PLANT EXPANSION
 MISCELLANEOUS DETAILS
 No. 3
 CITY OF O'FALLON, MISSOURI

JOB NO.: 9234
 DATE: 10-08-2001

DESIGNED BY: TMS
 DRAWN BY: DMH
 CHECKED BY: RJR/TMS
 SHEET NUMBER

GO.20