

GEOGRID SECTION #2
NOT TO SCALE

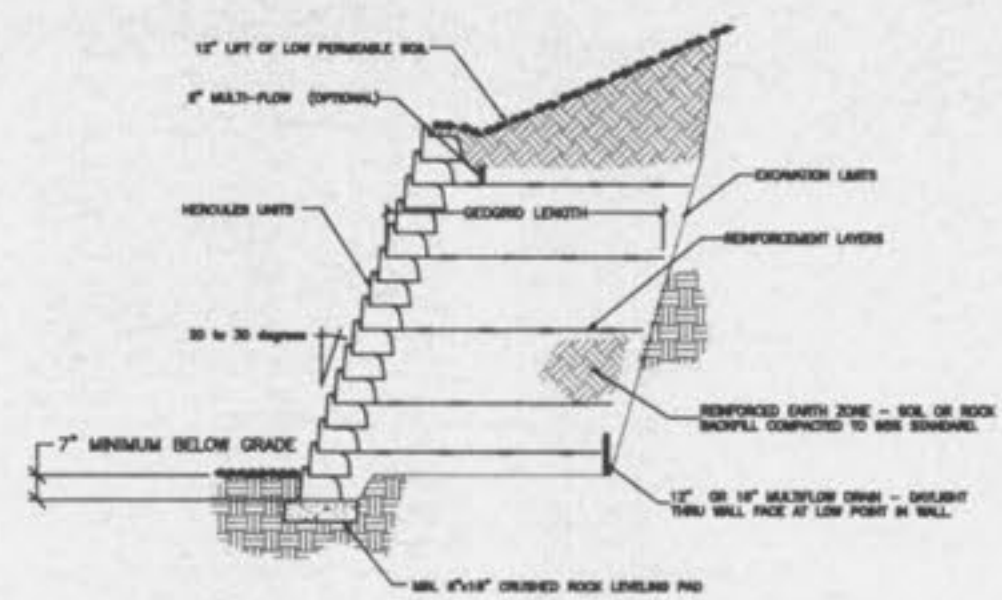

GEOGRID SECTION #1
NOT TO SCALE

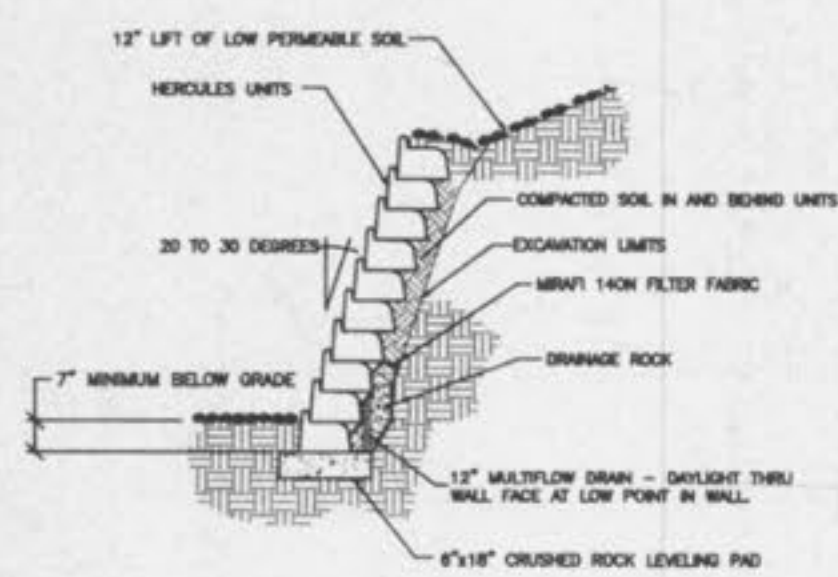

HERCULES WITH DRAINAGE ROCK
NOT TO SCALE

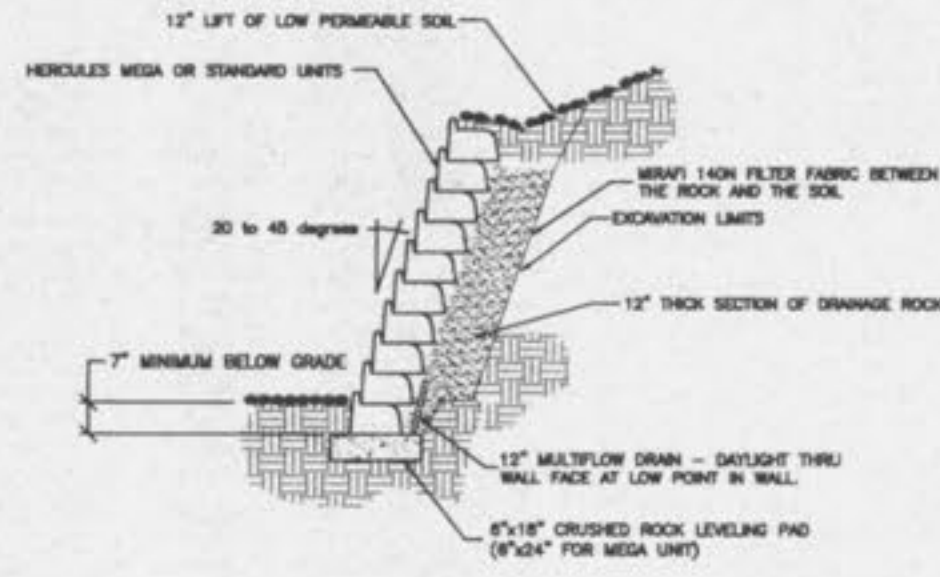

HERCULES WITH BASE DRAIN SECTION
NOT TO SCALE

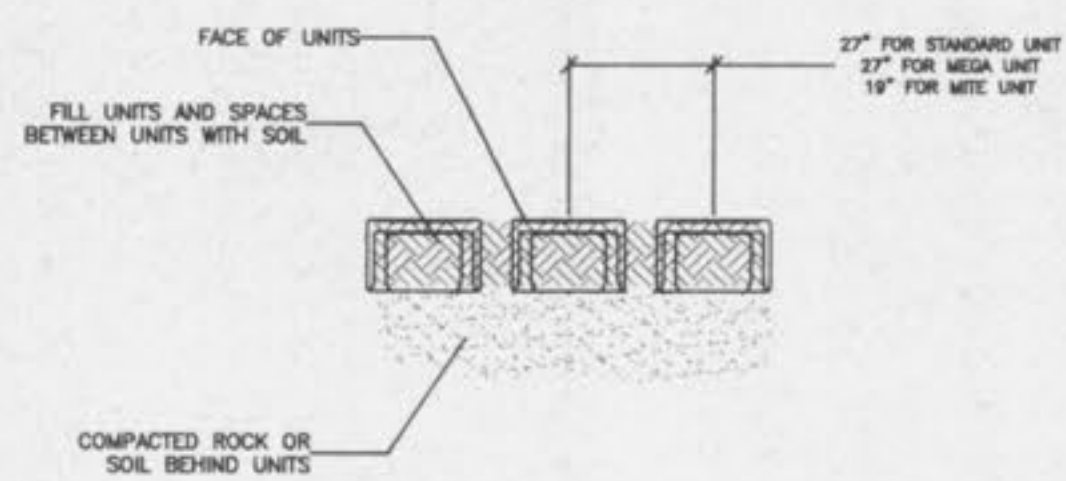

LEVELING PAD DETAIL
NOT TO SCALE

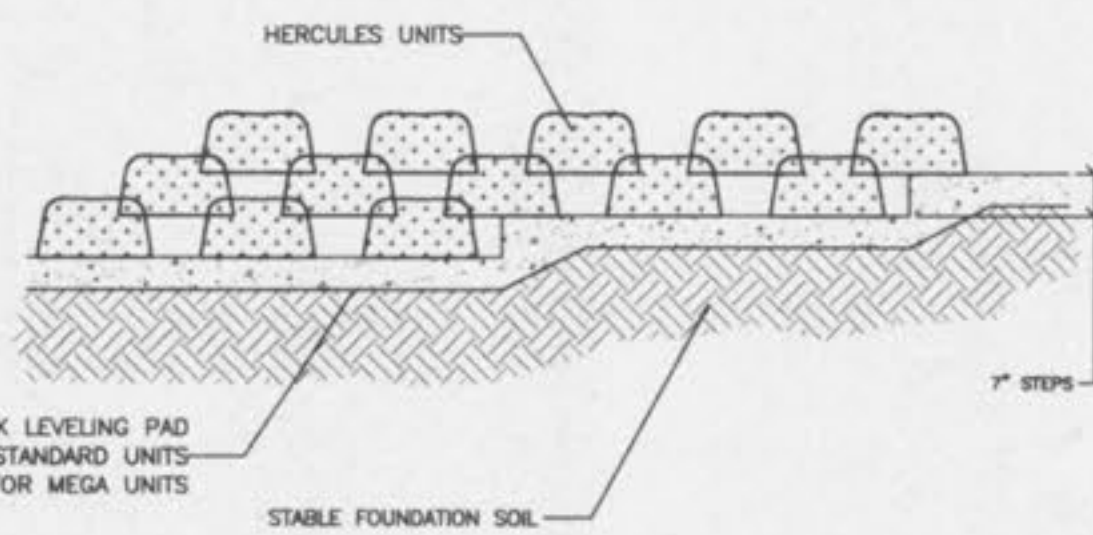

LEVELING PAD DETAIL
NOT TO SCALE

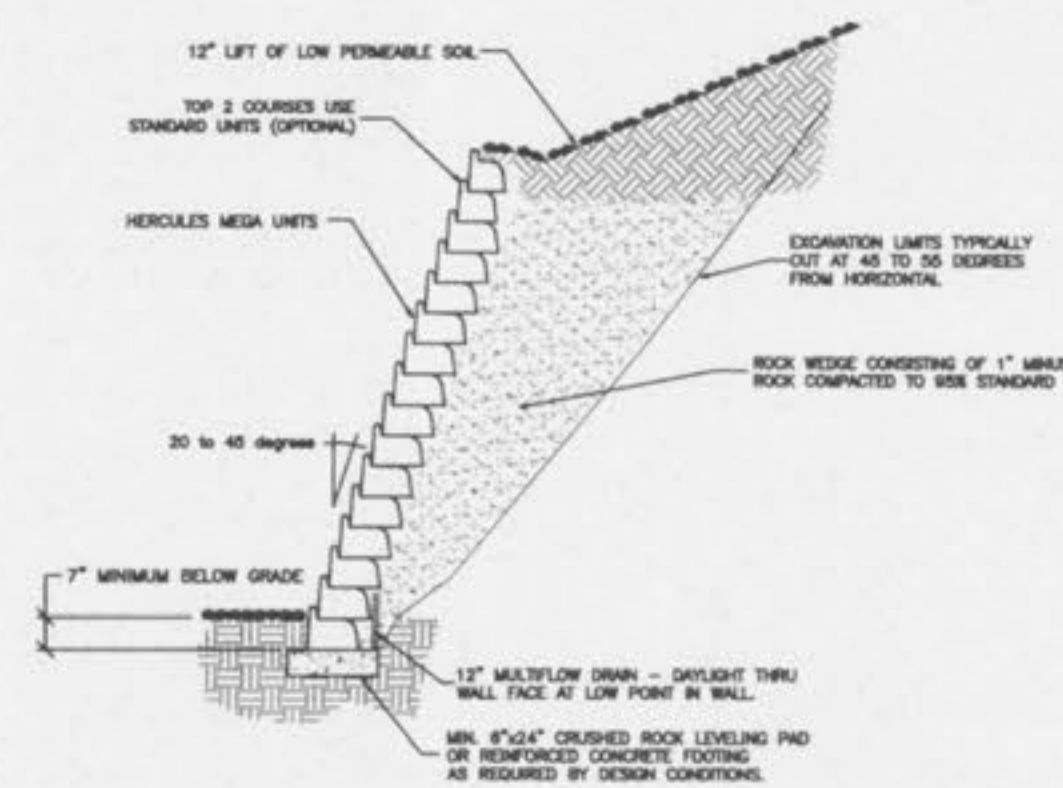

ROCK WEDGE SECTION
NOT TO SCALE

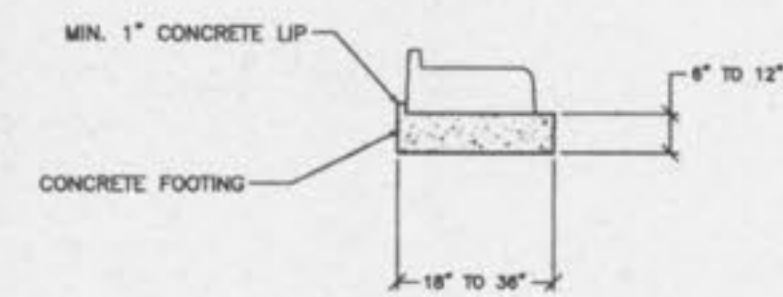

FOOTING OPTIONS
NOT TO SCALE

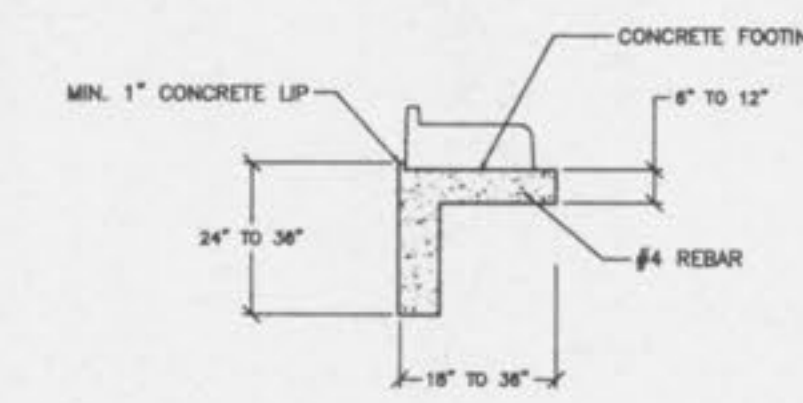

FOOTING OPTIONS
NOT TO SCALE

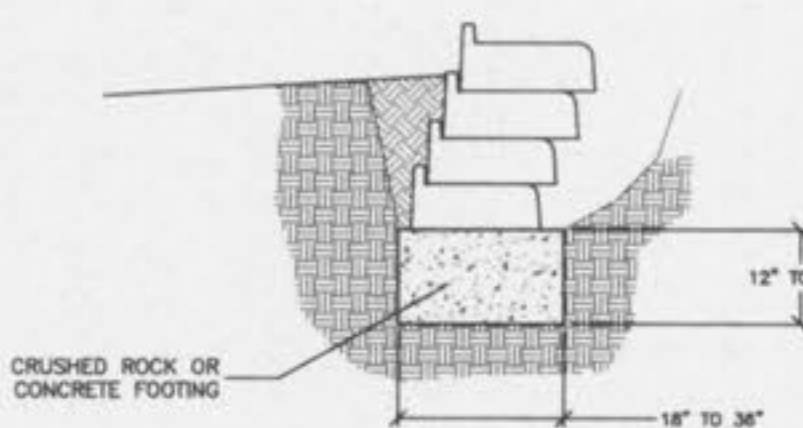

FOOTING OPTIONS
NOT TO SCALE

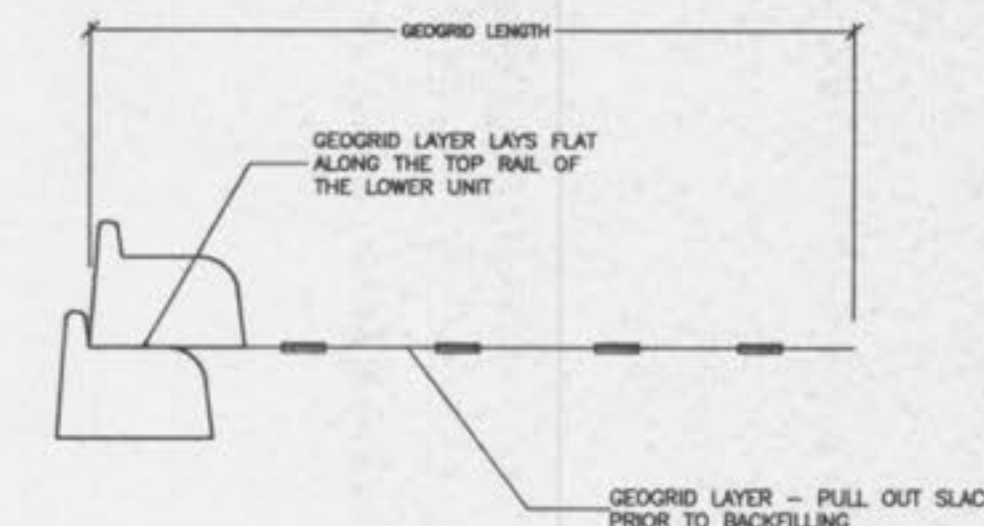

GEOGRID CONNECTION DETAIL
NOT TO SCALE

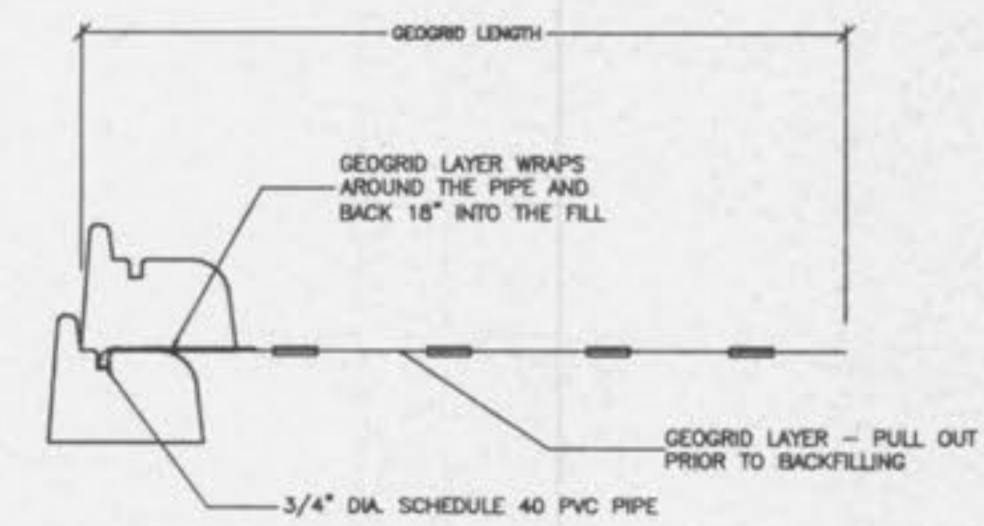

HERCULES \"WRAPPED PIPE\" CONNECTION
NOT TO SCALE

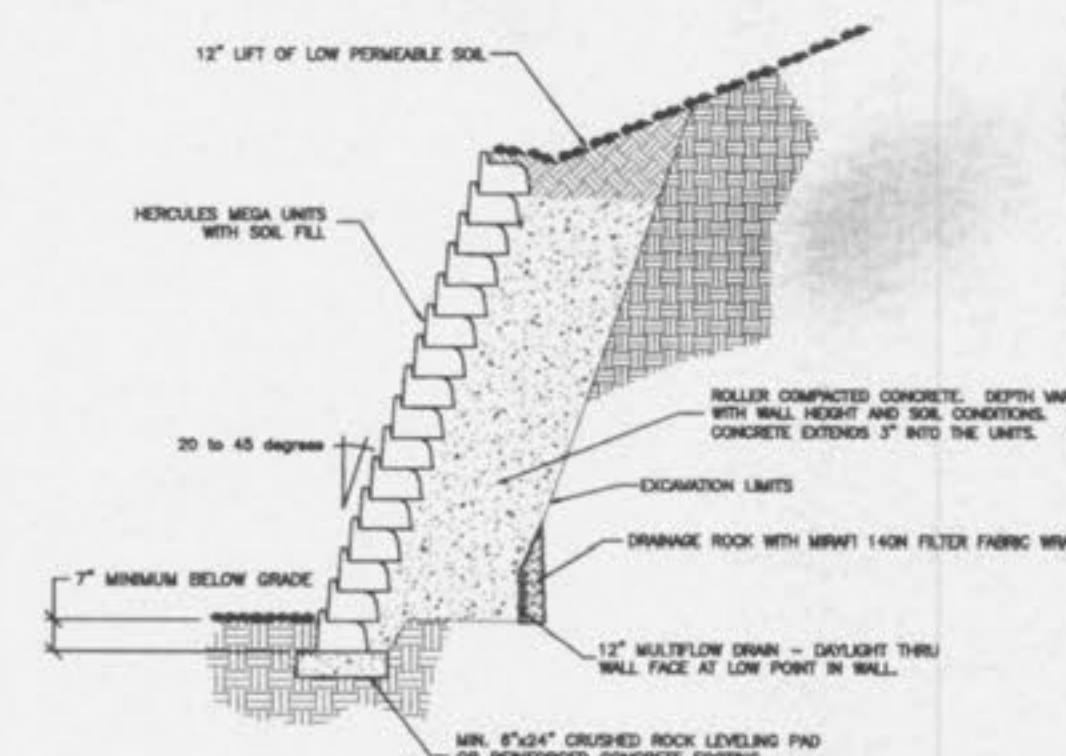

ROLLER COMPACTED CONCRETE SECTION
NOT TO SCALE

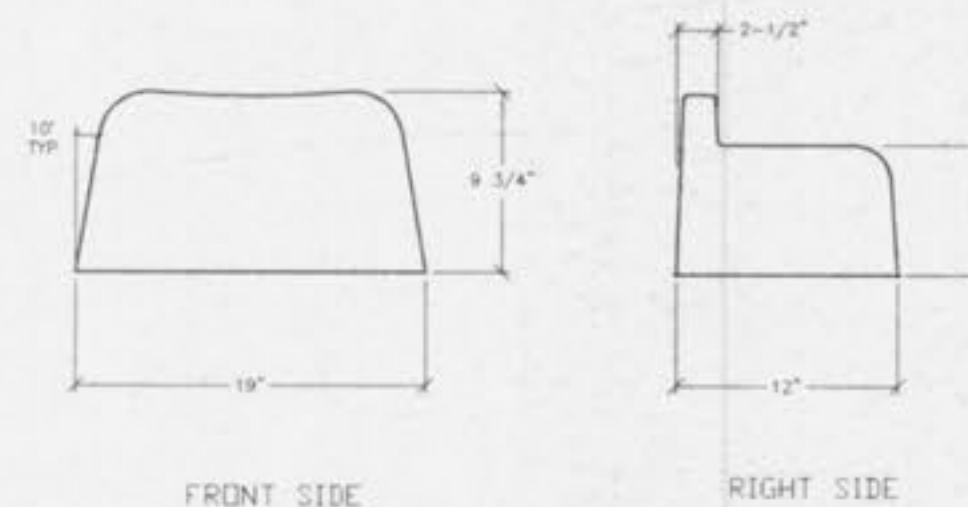

FRONT SIDE RIGHT SIDE

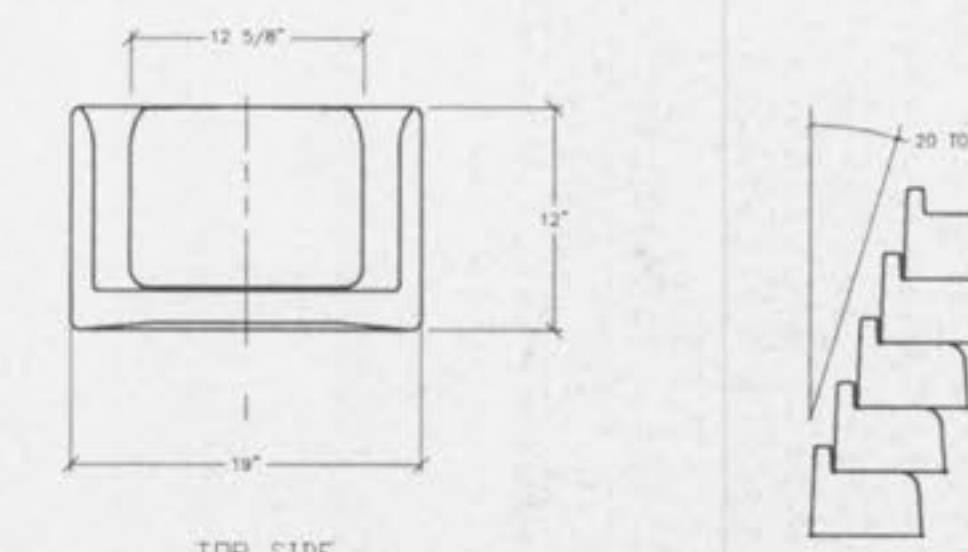

TOP SIDE
STANDARD UNIT
NOT TO SCALE

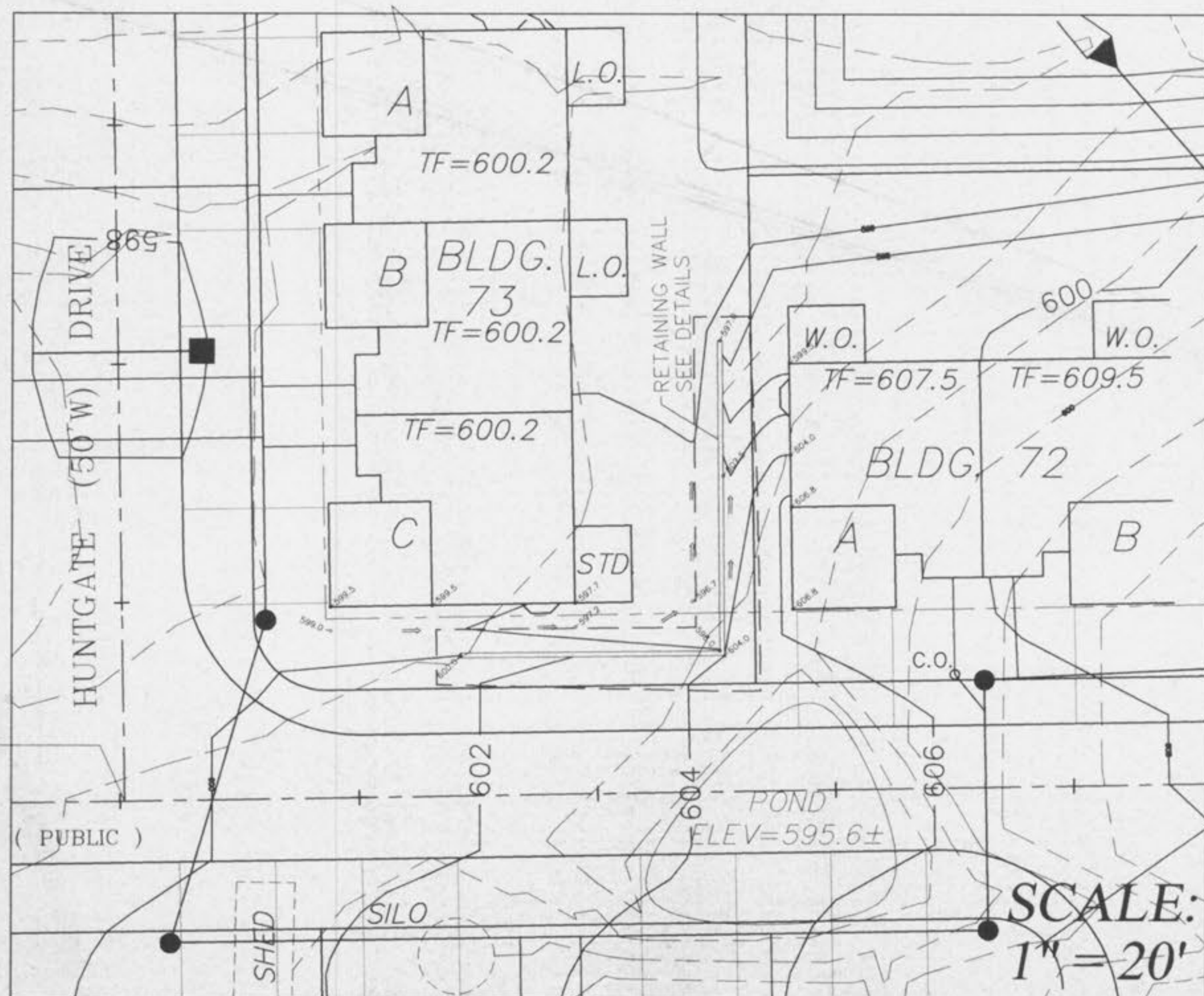

RETAINING WALL DETAIL

NOTE: RETAINING WALL EASEMENTS ARE BASED ON THE FOLLOWING:
 1. INSTALLATION PER "HERCULES WITH DRAINAGE ROCK" SECTION
 2. 5' FROM BASE OF WALL
 3. 5' OUTSIDE OF 20' BATTER FROM INSIDE EDGE OF FOOTING

PICKETT RAY & SILVER

333 Mid Rivers Mall Drive
 St. Peters, MO 65376
 Phone (636) 397-1211
 Fax (636) 397-1104

CIVIL ENGINEERS
 PLANNERS
 LAND SURVEYORS

WHITE GATE VILLAS
 ADDITION
 RETAINING WALL DETAILS

219 FOX HILL ROAD
 ST. CHARLES, MO 63301
 636-940-9300

Prepared For:
 SUMMIT POINTE L.C.

REVISIONS	NO.	DATE	BY	CHKD.
	1	09-08-02	REV. PER CITY OF O'FALLON	
	2	09-23-02	REV. PER CITY OF O'FALLON	

ENGINEER'S AUTHENTICATION
 The responsibility for professional engineering liability on this project is hereby limited to the set of plans authenticated by the seal, signature, and date hereunder attached. Responsibility is disclaimed for all other engineering plans involved in this project and specifically excludes revisions after this date unless reauthenticated.



DRAWN	ABK	DATE	AUG, 2002
CHECKED	D.W.D.	DATE	AUG, 2002
PROJECT #	01241SUPO.02R	TASK #	0
		FIELD BOOK	0