

SIZE	CATALOG NO.	A	B	C	D	E	F	G	H	CT	PT
4"	334-040	4.56	8.23	4.25	4.10	3.94	4.80	2.72	2.7	.32	.25
6"	334-060	6.68	9.93	6.31	4.57	5.88	6.90	3.72	3.5	.45	.36

DUCKETT CREEK SANITARY DISTRICT

SDR-35 x C900 BELL AND SPIGOT ADAPTERS
 Des. By: BSM App. By: KLA Detail No. 19A
 Cld. By: MDOB Date: 1-3-01

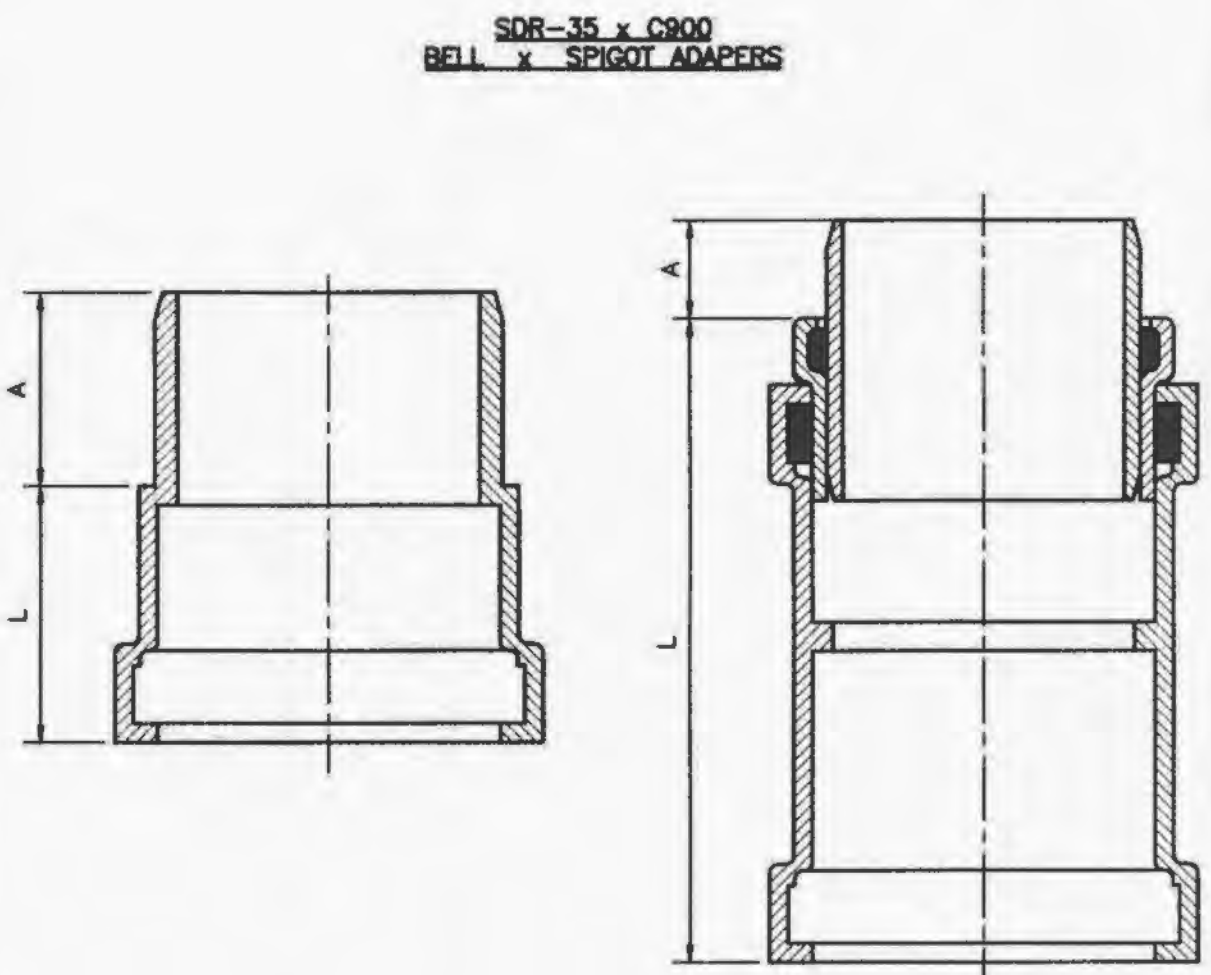

SIZE	CATALOG NO.	A	L	STYLE
4"	335-040	3.2	10.0	FABRICATED
6"	335-060	2.9	3.5	HARCO
8"	335-080	4.0	12.5	FABRICATED

DUCKETT CREEK SANITARY DISTRICT

SDR-35 x C900 BELL AND SPIGOT SPECIAL 4", 6" & 8" ADAPTERS
 Des. By: BSM App. By: KLA Detail No. 19B
 Cld. By: MDOB Date: 1-3-01

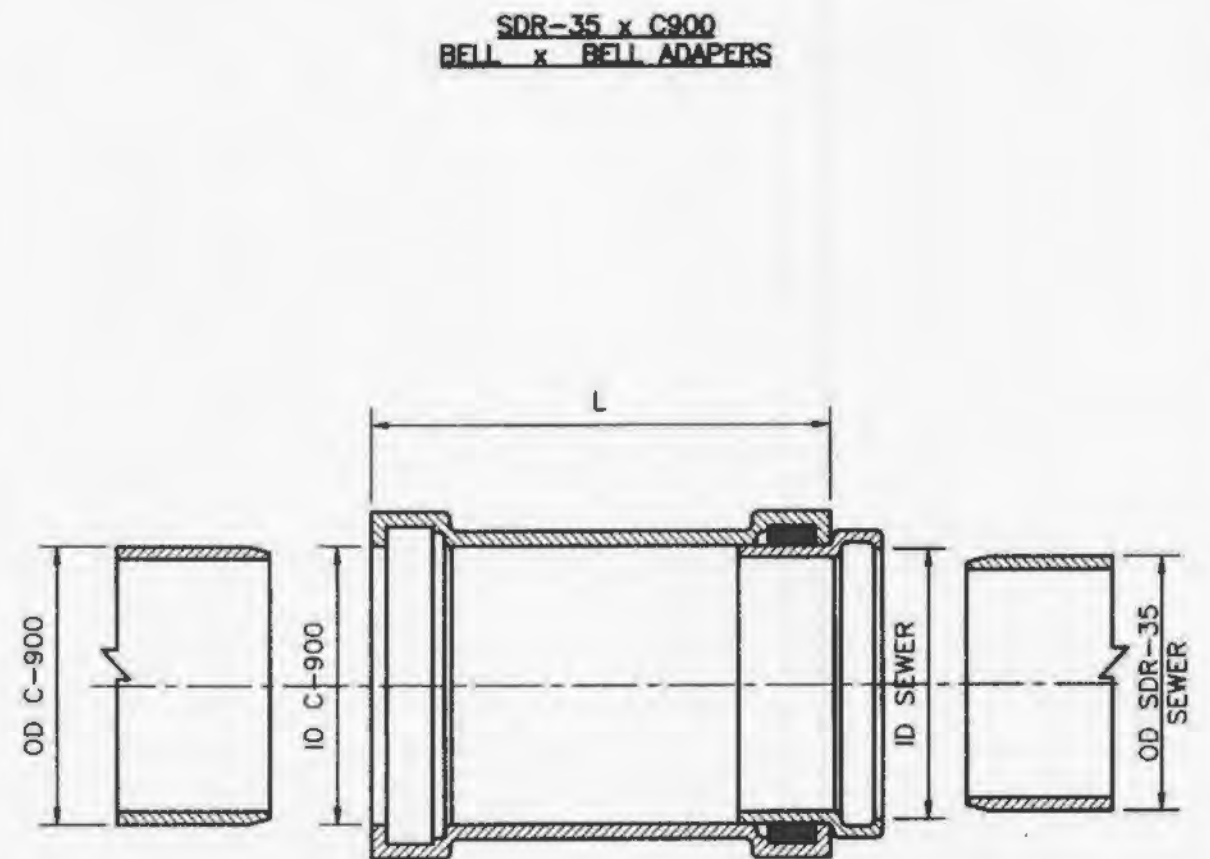

SIZE	CATALOG NO.	OD C900 SEWER	OD C900 SEWER	ID C900 SEWER	ID C900 SEWER	L	CTN QTY	CTN WT
4x4	337-040	4.80	4.215	4.86	4.25	10.0	1	4
6x6	337-060	6.90	6.275	6.96	6.32	11.13	1	8
8x8	337-080	9.05	8.400	9.13	8.45	12.50	1	15

DUCKETT CREEK SANITARY DISTRICT

SDR-35 x C900 BELL AND BELL 4", 6" & 8" ADAPTERS
 Des. By: BSM App. By: KLA Detail No. 19C
 Cld. By: MDOB Date: 1-3-01

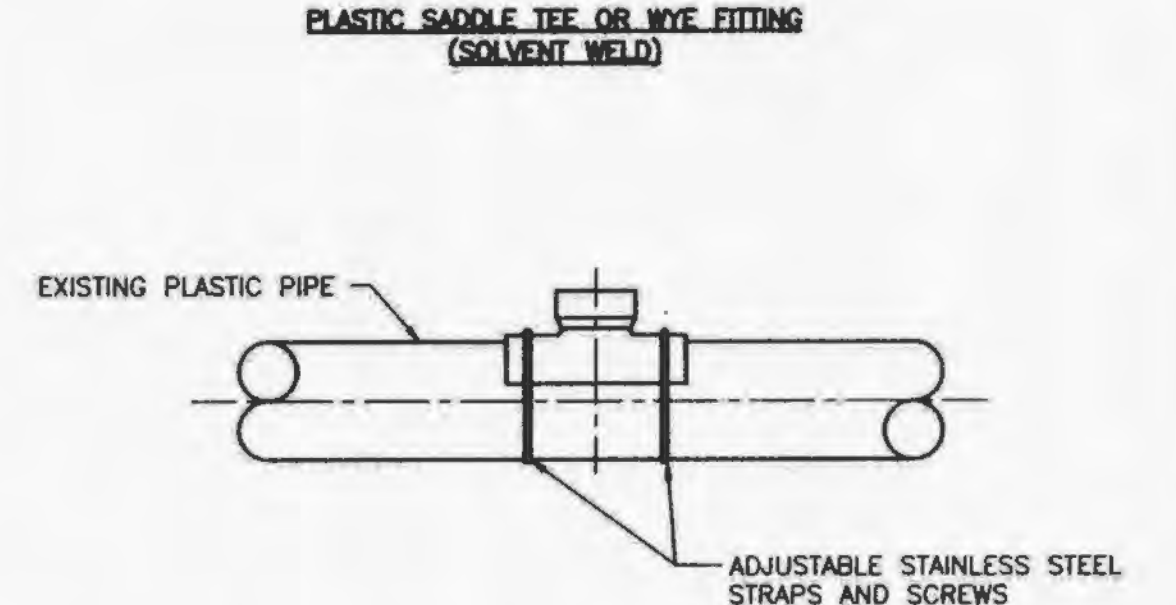

WHEN CONNECTION TO A PLASTIC PIPE IS ALLOWED AND A CONNECTION IS LARGER THAN 6" IN DIAMETER, A SOLVENT WELD WYE OR TEE FITTING OF A SIMILAR MATERIAL MUST BE USED. (EXAMPLE: 10" x 8")
 THIS IS ACCOMPLISHED BY CAREFULLY CUTTING A HOLE WITH A SAW IN THE MAIN AT THE REQUIRED LOCATION AFTER CUTTING AND SHAPING THE HOLE TO THE SIZE OF THE FITTING. THE FOLLOWING STEPS SHOULD BE TAKEN.

- CLEAN AND DRY BOTH INSIDE THE SADDLE WYE SURFACE AND PIPE SURFACE TO BE SOLVENT CEMENTED.
- IMPORTANT:** APPLY A LIBERAL, HEAVY COAT OF ONE-STEP SOLVENT CEMENT TO THE INSIDE SURFACE OF THE SADDLE WYE AND TO THE EXTERIOR WELDING SURFACE TO THE PIPE.
- WITHOUT DELAY, MATE THE SURFACES AND STRAP DOWN TIGHTLY. A BEAD OF SOLVENT SHOULD APPEAR AFTER THE SADDLE HAS BEEN STRAPPED DOWN TIGHTLY.
- USING A RAG OR PAPER TOWEL, WIPE BEAD AND ANY EXCESS SOLVENT CEMENT OFF PIPE AND SADDLE.
- ALLOW 30-60 MINUTES FOR SET-UP TIME BEFORE BACKFILLING. CURE TIME DEPENDS ON SIZE FIT OF MATERIALS BEING INSTALLED AND VARIOUS COLD DAMP CONDITIONS.
- DISCARD OLD SOLVENT IF IT BECAME JELLED OR LUMPY.
- A CLEAN, DRY BEDDING MATERIAL IS REQUIRED AROUND THE COMPLETED CONNECTION BEFORE BACKFILLING. THE BEDDING MATERIAL SHOULD BE ONE OF THE FOLLOWING.
 - A 1 TO 3 CEMENT TO SAND MIX
 - "PRE-MIX" CONCRETE.
 - DCSD APPROVED BEDDING FOR SANITARY SEWERS.

DUCKETT CREEK SANITARY DISTRICT

8" & LARGER CONNECTION TO PLASTIC MAIN
 Des. By: BSM App. By: KLA Detail No. 20A
 Cld. By: MDOB Date: 1-4-01

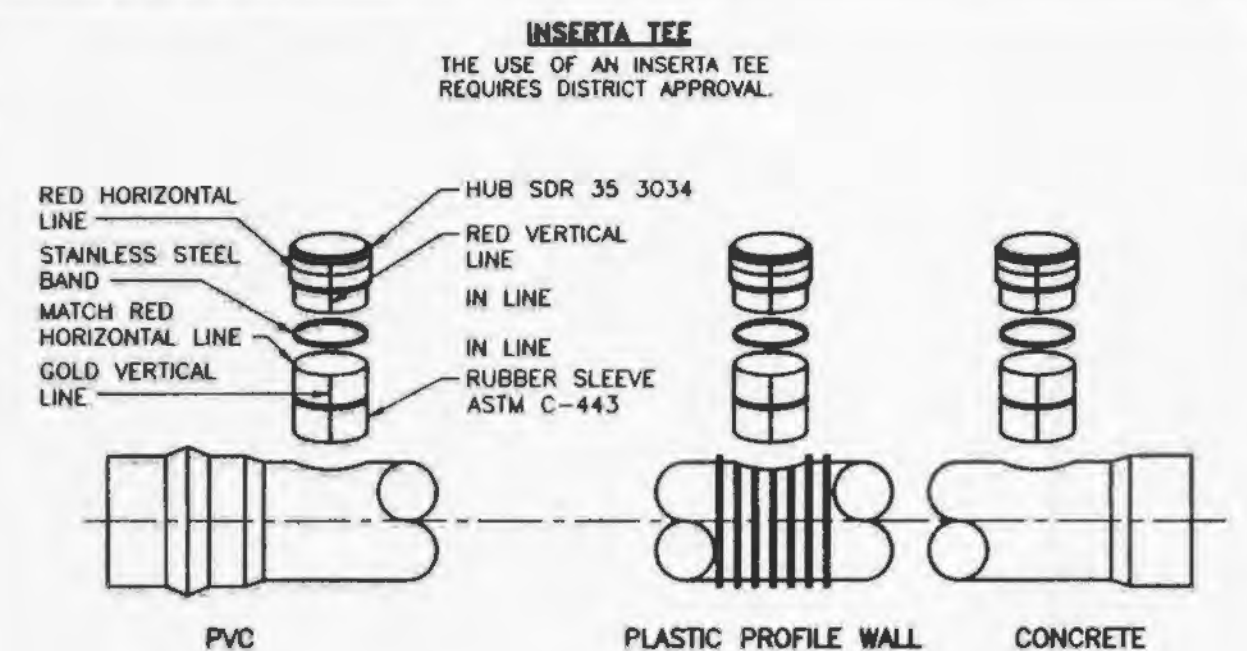

- INSTALLATION PROCEDURE:**
- CORE THE PROPER SIZE HOLE. TEE SIZE: 4" 6" 8" 10" 12" 15"
 BIT SIZE: 4 1/2" 6 1/2" 8 1/2" 10 1/2" 12 1/2" 15 1/2"
 - INSERT THE RUBBER SLEEVE (1) IN THE CORED HOLE WITH THE GOLD VERTICAL LINE ON THE RUBBER SLEEVE (2) FACING TO THE SID OF THE MAIN LINE. THE UPPER SEGMENT SHOULD BE ON TOP OF THE WALL OR RIG AND THE LOWER SEGMENT (PVC, PROFILE WALL, AND POLYETHYLENE PIPE ONLY) SHOULD BE ON THE INSIDE OF THE PIPE.
 - APPLY THE INSERTA TEE SOLUTION SUPPLIED TO THE INSIDE OF THE RUBBER SLEEVE AND TO THE OUTSIDE OF THE PVC HUB ADAPTER. CAUTION - DO NOT USE AN OIL BASED LUBRICANT.
 - PLACE THE PVC HUB ADAPTER (3) INTO THE RUBBER SLEEVE. MAKE SURE THAT THE RED VERTICAL LINE (4) ON THE PVC HUB ADAPTER IS IN LINE WITH THE GOLD VERTICAL LINE (2) ON THE RUBBER SLEEVE.
 - PLACE THE 2x4 BOARD ONTO THE TOP OF THE PVC HUB ADAPTER.
 - THE RED HORIZONTAL LINE (5) AT THE TOP OF THE HUB ADAPTER IS A DEPTH MARK. THIS TELLS THE INSTALLER HOW FAR TO DRIVE THE ADAPTER INTO THE RUBBER SLEEVE. DRIVE THE PVC HUB ADAPTER INTO THE RUBBER SLEEVE TO WHERE THE HORIZONTAL RED LINE (5) ON THE PVC HUB ADAPTER (3) MEETS THE TOP OF THE RUBBER SLEEVE (6).
 - PLACE THE STAINLESS STEEL BAND (7) AROUND THE TOP OF THE RUBBER SLEEVE AND TIGHTEN DOWN.
 - INSTALL PIPE IN NORMAL MANNER.

DUCKETT CREEK SANITARY DISTRICT

INSERTA TEE DETAILS AND SPECIFICATIONS
 Des. By: BSM App. By: KLA Detail No. 20B
 Cld. By: MDOB Date: 1-4-01

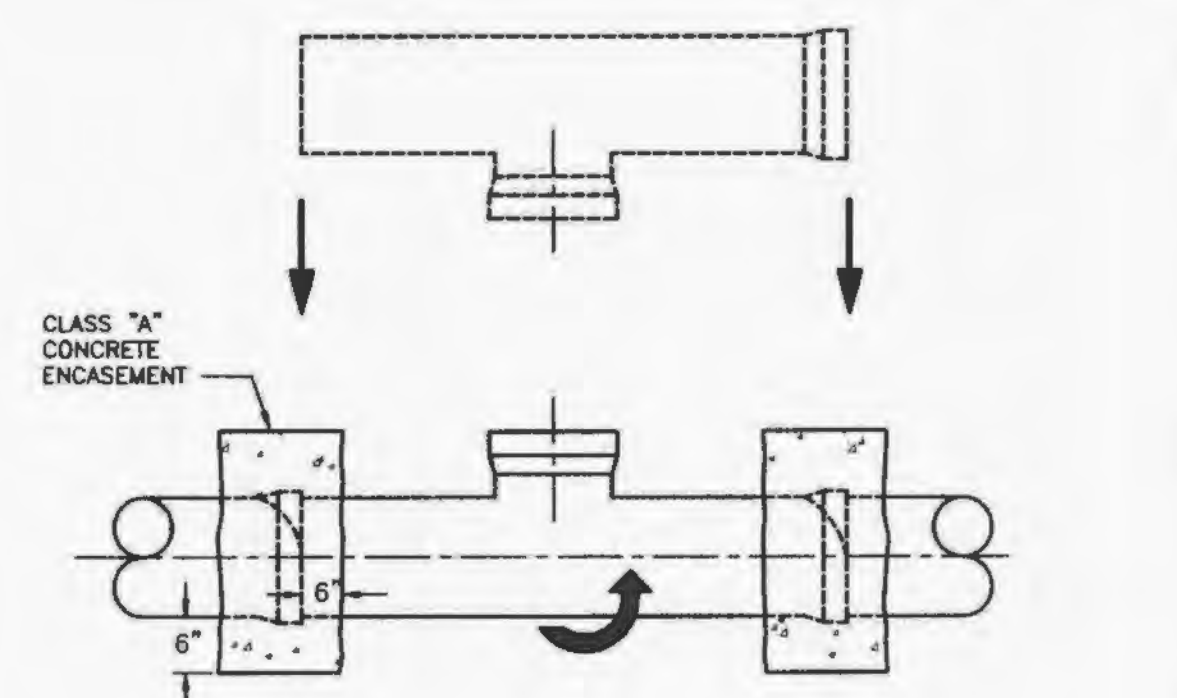

- NOTES:**
- WHEN A CONNECTION IS ALLOWED LARGER THAN 6" DIAMETER A SADDLE MAY BE USED IF THE I.D. OF THE CONNECTION PIPE IS NOT GREATER THAN ONE HALF (1/2) OF THE I.D. OF THE MAIN SEWER. (EXAMPLE: 24" x 10")
 - IF THE I.D. OF THE CONNECTION PIPE IS GREATER THAN ONE HALF (1/2) THE I.D. OF THE MAIN SEWER THE WYE OR TEE MUST BE "ROLLED IN". (EXAMPLE: 15" x 8")
 - THIS IS ACCOMPLISHED BY BREAKING AWAY AND REMOVING ONE SECTION OF PIPE. THE TOP HALF OF THE BELL ON THE PIPE LYING ADJACENT TO THE GAP IS CAREFULLY BROKEN OFF. THE TOP HALF OF THE BELL ON THE MAIN REPLACEMENT SECTION (WITH A "TEE" WYE) FITTING IS ALSO BROKEN OFF. THE REPLACEMENT PIPE IS THEN PLACED IN THE LINE GAP WITH THE STUB POINTED IN THE WRONG DIRECTION. THE BROKEN BELLS ON THE REPLACEMENT AND ADJOINING PIPE MAKE IT POSSIBLE FOR THE REPLACEMENT SECTION TO FIT INTO THE SEWER LINE WITHOUT DISTURBING THE ADJOINING PIPE SECTIONS. THE REPLACEMENT SECTION IS THEN ROTATED TO THE DESIRED POSITION AND THE BROKEN BELLS ARE ENCASED WITH A 6" CLASS "A" CONCRETE ENCASEMENT.
 - I.D. OF MAIN SEWER SHALL NOT BE DECREASED BY A ROLL-IN CONNECTION.

DUCKETT CREEK SANITARY DISTRICT

"ROLL-IN" (FOR EXISTING CLAY OR CONCRETE PIPE)
 Des. By: BSM App. By: KLA Detail No. 21
 Cld. By: MDOB Date: 1-5-01

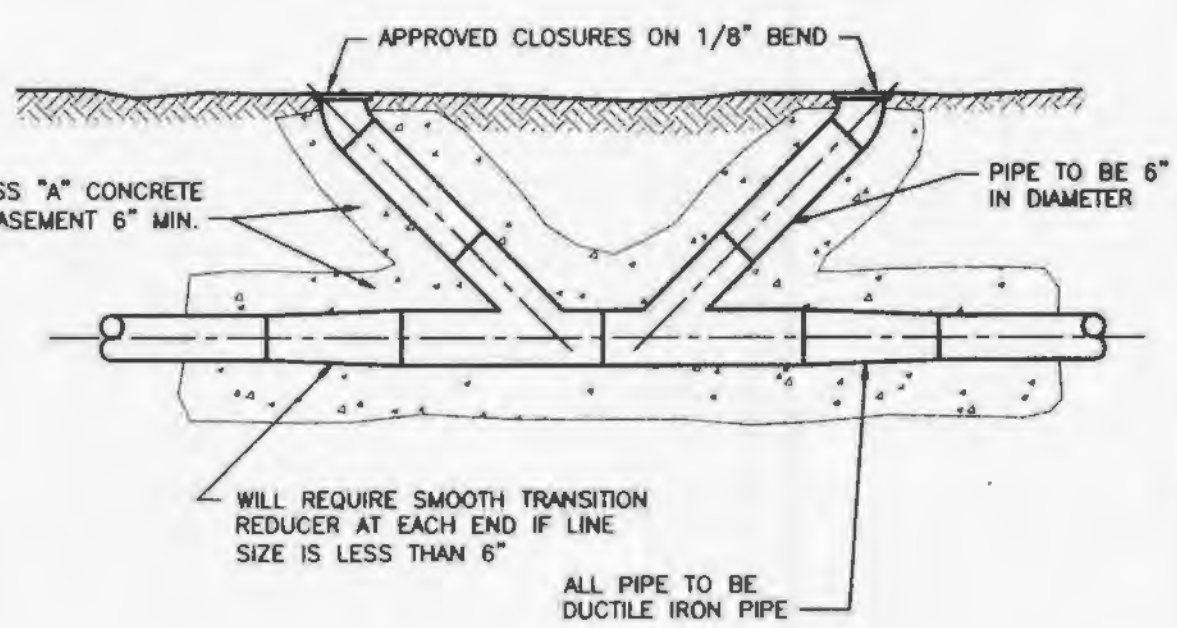

1800' MAXIMUM SPACING

DUCKETT CREEK SANITARY DISTRICT

FORCE MAIN CLEANOUT (6" DIA. & SMALLER)
 Des. By: BSM App. By: KLA Detail No. 22
 Cld. By: MDOB Date: 1-5-01

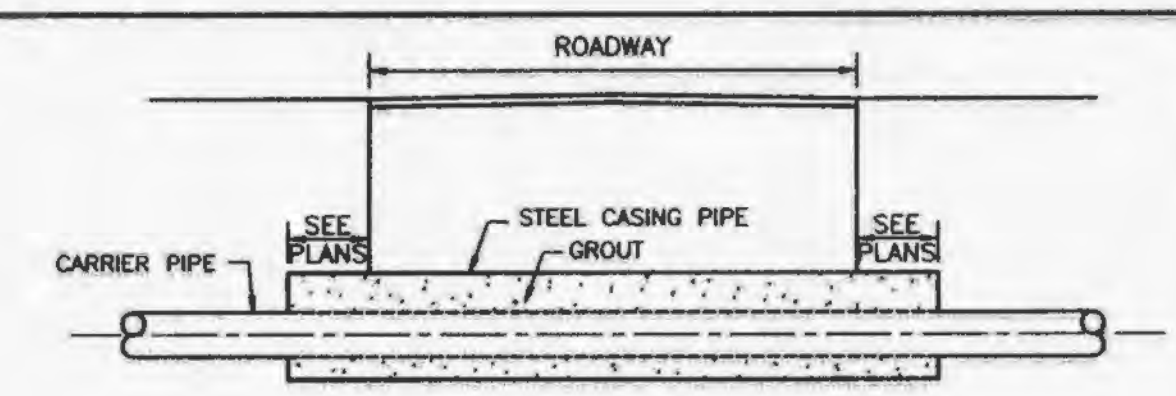

- NOTES:**
- INSIDE DIAMETER OF CASING PIPE TO BE MINIMUM OF 4" GREATER THAN COUPLING DIAMETER OF CARRIER PIPE.
 - ENCASEMENTS TO BE INSTALLED UNDER THE ROAD BY MEANS OF JACKING IT THROUGH, OR BY DRY BORING A HOLE THAT WILL RECEIVE THE CASING WITH A SHUG FIT.
 - THE OUTSIDE DIAMETER OF THE CASING SHALL NOT BE LESS THAN, NOR MORE THAN ONE INCH GREATER THAN THE BORED HOLE.
 - THE ANNULAR SPACE BETWEEN THE CASING PIPE AND THE BORED HOLE SHALL BE FILLED WITH GROUT.

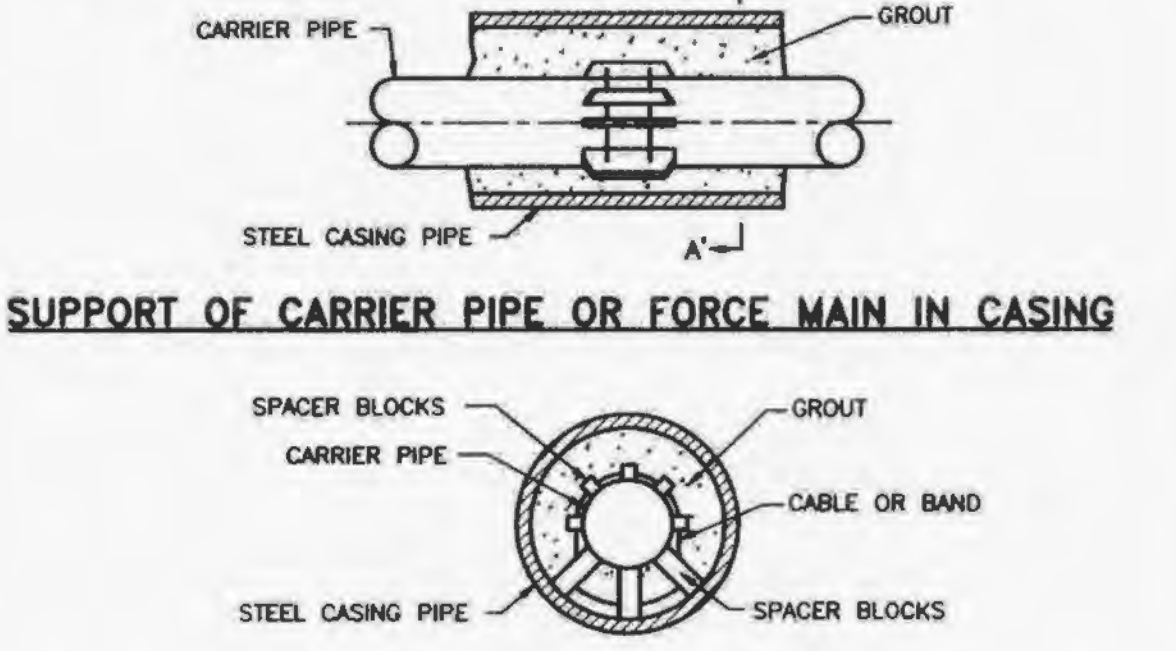

DUCKETT CREEK SANITARY DISTRICT

ROADWAY BORING DETAIL
 Des. By: BSM App. By: KLA Detail No. 23
 Cld. By: MDOB Date: 1-5-01

PROJECT TITLE
 WYNDGATE VILLAGE B
 PLAT TWO

PICKETT, RAY & SILVER INC
 CIVIL ENGINEERING, LAND SURVEYING,
 AND NATURAL RESOURCES SERVICES
 110 West Adams, Suite 201
 Branson, Mo 65616
 Phone (636) 387-1211 Fax (636) 387-1104
 www.prs3.com 1-800-708-3918

ENGINEERS AUTHENTICATION
 THE RESPONSIBILITY FOR PROFESSIONAL ENGINEERING LIABILITY OF THIS PROJECT IS HEREBY LIMITED TO THE SET OF PLANS AUTHENTICATED BY THE SEAL, SIGNATURE, AND DATE HEREUNDER ATTACHED. RESPONSIBILITY IS DECLINED FOR ALL OTHER ENGINEERING PLANS INVOLVED IN THIS PROJECT AND SPECIFICALLY EXCLUDES REVISIONS AFTER THIS DATE UNLESS REAUTHENTICATED.
 PICKETT, RAY & SILVER INC
 10 LICENSE, ENGINEERS
 REGISTERED PROFESSIONAL ENGINEER
 NUMBER 23847
 EXPIRES 12/31/11
 DULAS S. TOWAN
 PROFESSIONAL ENGINEER LICENSE E-22045

Developer / Owner Information
 McBride Wyndgate, LLC
 16091 Swingley Ridge Road, Suite 300
 Chesterfield, Missouri 63077

P+Z No. 3203

City No.

Page No.

18 of 24

FRS No. 01267.MCSO.04R

CITY OF O'FALLON - Duckett Creek Sanitary District Details