



ENGINEERING

PLANNING

SURVEYING



STORMWATER DETENTION ANALYSIS

REPORT FOR

LIVING WORD CHRISTIAN SCHOOL

O'Fallon, Missouri

Prepared By: BAX ENGINEERING CO. INC.

Bax Project #: 97-9203F

October 19, 1998

Revised December 23, 1998

Modified Per As-Built: April 19, 2006

BAX ENGINEERING CO., INC.
221 Point West Blvd.
St. Charles, MO 63301 1
636-928-5552 FAX 928-1718



ENGINEERING

PLANNING

SURVEYING

INTRODUCTION:

The purpose of this report is to analyze the storm water detention basins proposed for Living Word Christian School as shown on a plan prepared by Bax Engineering Co. Inc. Two basins are proposed for this development. This site is divided into two subwatersheds which both discharge to a common tributary of Belleau Creek at Tom Ginnever Road. Two basins will provide the necessary attenuation a "West Basin" which is located in the Northwest corner of the site and an "East Basin" which is located in the Southeast corner of the site. The storage volume and outflow rates have been proportioned to insure that the peak rate of runoff leaving the site under post-developed conditions does not exceed the peak rate of runoff leaving the site under pre-developed conditions. The basins have been analyzed to allow the passage of a 100 year frequency-20 minute design storm. The attached calculations are based on the four design storms listed below:

- 2 year frequency-20 minute duration design storm.
- 15 year frequency-20 minute duration design storm.
- 25 year frequency-20 minute duration design storm
- 100 year frequency-20 minute duration design storm

The proposed basins have been designed to provide detention for portions of the future offsite commercial and industrial developments within this watershed. The Basins have been analyzed for the following conditions.

- Ultimate Development – Total development of the School and the future commercial and industrial sites.
- Proposed Development – Ultimate development of the School site.



ENGINEERING

PLANNING

SURVEYING

The storm runoff from these future commercial and industrial sites will be collected into a storm drainage system and piped to the detention basins. Detention has not been provided for any additional development of the future commercial and industrial areas outside of the area indicated on the offsite drainage area map.

TIME OF CONCENTRATION CALCULATIONS:

West Drainage Area

The most remote point of this drainage area is located 1,800 feet Northwest of the outlet. The difference in elevation of this remote point and the outlet is 35 feet. Using this information the time of concentration was calculated as follows:

$$L = 1,800 \text{ feet}$$

$$S = 35 \text{ feet} / 1,800 \text{ feet} = 0.019$$

$$t_c = (0.0078) (L/S^{0.5})^{0.77} = 11.52 \text{ minutes}$$

East Drainage Area

The most remote point of the drainage area is located 1,300 feet Northeast of the basin outlet. The difference in elevation of this remote point and the basin outlet is 30 feet. Using this information the time of concentration was calculated as follows:

$$L = 1,300 \text{ feet}$$

$$S = 30 \text{ feet} / 1,300 \text{ feet} = 0.0231$$

$$t_c = (0.0078) (L/S^{0.5})^{0.77} = 8.31 \text{ minutes}$$



ENGINEERING

PLANNING

SURVEYING

ULTIMATE DEVELOPMENT

Attenuation and Permitted Release Rate Calculations:

WEST Basin 2 year – 20 minute Design Storm

Pre-Developed

Area	% impervious	C.I. Factor	Q
20.00 acres	5%	1.15 cfs/acre	23.00 cfs
7.00 acres	5%	1.15 cfs/acre	8.05 cfs
4.90 acres	5%	1.15 cfs/acre	5.64 cfs
14.28 acres	5%	1.15 cfs/acre	16.42 cfs
Total Q			53.11 cfs

Post-Developed

Area	% impervious	C.I. Factor	Q
20.00 acres	100%	2.39 cfs/acre	47.80 cfs
7.00 acres	5%	1.15 cfs/acre	8.05 cfs
4.90 acres	5%	1.15 cfs/acre	5.64 cfs
5.67 acres	100%	2.39 cfs/acre	13.55 cfs
5.39 acres	5%	1.15 cfs/acre	6.20 cfs
Total Q			81.23 cfs

Flow to WEST Basin:

Area	% impervious	C.I. Factor	Q
20.00 acres	100%	2.39 cfs/acre	47.80 cfs
7.00 acres	5%	1.15 cfs/acre	8.05 cfs
0.87 acres	5%	1.15 cfs/acre	1.00 cfs
Total Q			56.85 cfs



ENGINEERING

PLANNING

SURVEYING

ULTIMATE DEVELOPMENT

Attenuation and Permitted Release Rate Calculations :

EAST Basin 2 year – 20 minute Design Storm

Pre-Developed

Area	% impervious	C.I. Factor	Q
6.75 acres	5%	1.15 cfs/acre	7.76 cfs
10.80 acres	5%	1.15 cfs/acre	12.42 cfs
5.71 acres	5%	1.15 cfs/acre	6.57 cfs
Total Q			26.75 cfs

Post-Developed

Area	% impervious	C.I. Factor	Q
6.75 acres	100%	2.39 cfs/acre	16.13 cfs
10.80 acres	100%	2.39 cfs/acre	25.81 cfs
4.29 acres	100%	2.39 cfs/acre	10.25 cfs
4.64 acres	5%	1.15 cfs/acre	5.34 cfs
Total Q			57.53 cfs

Flow to EAST Basin:

Area	% impervious	C.I. Factor	Q
6.75 acres	100%	2.39 cfs/acre	16.13 cfs
10.80 acres	100%	2.39 cfs/acre	25.81 cfs
2.69 acres	100%	2.39 cfs/acre	6.43 cfs
4.04 acres	5%	1.15 cfs/acre	4.65 cfs
Total Q			53.02 cfs

Required Attenuation:

$$\begin{aligned}
 \text{Attenuation} &= (Q_{\text{post-developed West Basin}} + Q_{\text{post-developed East Basin}}) \\
 &\quad - (Q_{\text{pre-developed West Basin}} + Q_{\text{pre-developed East Basin}}) \\
 &= (81.23 \text{ cfs} + 57.53 \text{ cfs}) - (53.11 \text{ cfs} + 26.75 \text{ cfs})
 \end{aligned}$$

$$\text{Attenuation} = \mathbf{58.90 \text{ cfs}}$$



ENGINEERING

PLANNING

SURVEYING

Permitted Release rate:

$$\begin{aligned} \text{Permitted Release Rate} &= (Q_{\text{in-flow to West Basin}} + Q_{\text{in-flow to East Basin}}) - \text{Attenuation} \\ &= (56.85 \text{ cfs} + 53.02 \text{ cfs}) - 58.90 \text{ cfs} \end{aligned}$$

Permitted Release Rate = 50.97 cfs

ULTIMATE DEVELOPMENT

Attenuation and Permitted Release Rate Calculations :

WEST Basin 15 year – 20 minute Design Storm

Pre-Developed

Area	% impervious	C.I. Factor	Q
20.00 acres	5%	1.87 cfs/acre	37.40 cfs
7.00 acres	5%	1.87 cfs/acre	13.09 cfs
4.90 acres	5%	1.87 cfs/acre	9.16 cfs
14.28 acres	5%	1.87 cfs/acre	26.70 cfs
Total Q			86.36 cfs

Post-Developed

Area	% impervious	C.I. Factor	Q
20.00 acres	100%	3.85 cfs/acre	77.00 cfs
7.00 acres	5%	1.87 cfs/acre	13.09 cfs
4.90 acres	5%	1.87 cfs/acre	9.16 cfs
5.67 acres	100%	3.85 cfs/acre	21.83 cfs
5.39 acres	5%	1.87 cfs/acre	10.08 cfs
Total Q			131.16 cfs

Flow to WEST Basin:

Area	% impervious	C.I. Factor	Q
20.00 acres	100%	3.85 cfs/acre	77.00 cfs
7.00 acres	5%	1.87 cfs/acre	13.09 cfs
0.87 acres	5%	1.87 cfs/acre	1.63 cfs
Total Q			91.72 cfs



ENGINEERING

PLANNING

SURVEYING

ULTIMATE DEVELOPMENT

Attenuation and Permitted Release Rate Calculations :

EAST Basin 15 year – 20 minute Design Storm

Pre-Developed

Area	% impervious	C.I. Factor	Q
6.75 acres	5%	1.87 cfs/acre	12.62 cfs
10.80 acres	5%	1.87 cfs/acre	20.20 cfs
5.71 acres	5%	1.87 cfs/acre	10.68 cfs
Total Q			43.50 cfs

Post-Developed

Area	% impervious	C.I. Factor	Q
6.75 acres	100%	3.85 cfs/acre	25.99 cfs
10.80 acres	100%	3.85 cfs/acre	41.58 cfs
4.29 acres	100%	3.85 cfs/acre	16.52 cfs
4.64 acres	5%	1.87 cfs/acre	8.68 cfs
Total Q			92.76 cfs

Flow to EAST Basin:

Area	% impervious	C.I. Factor	Q
6.75 acres	100%	3.85 cfs/acre	25.99 cfs
10.80 acres	100%	3.85 cfs/acre	41.58 cfs
2.69 acres	100%	3.85 cfs/acre	10.36 cfs
4.04 acres	5%	1.87 cfs/acre	7.55 cfs
Total Q			85.48 cfs

Required Attenuation:

$$\begin{aligned}
 \text{Attenuation} &= (Q_{\text{post-developed West Basin}} + Q_{\text{post-developed East Basin}}) \\
 &\quad - (Q_{\text{pre-developed West Basin}} + Q_{\text{pre-developed East Basin}}) \\
 &= (131.16 \text{ cfs} + 92.76 \text{ cfs}) - (86.36 \text{ cfs} + 43.50 \text{ cfs})
 \end{aligned}$$

$$\text{Attenuation} = \mathbf{94.06 \text{ cfs}}$$



ENGINEERING

PLANNING

SURVEYING

Permitted Release rate:

$$\begin{aligned} \text{Permitted Release Rate} &= (Q_{\text{in-flow to West Basin}} + Q_{\text{in-flow to East Basin}}) - \text{Attenuation} \\ &= (91.72 \text{ cfs} + 85.48 \text{ cfs}) - 94.06 \text{ cfs} \end{aligned}$$

Permitted Release Rate = 83.14 cfs

ULTIMATE DEVELOPMENT

Attenuation and Permitted Release Rate Calculations :

WEST Basin 25 year – 20 minute Design Storm

Pre-Developed

Area	% impervious	C.I. Factor	Q
20.00 acres	5%	2.37 cfs/acre	47.40 cfs
7.00 acres	5%	2.37 cfs/acre	16.59 cfs
4.90 acres	5%	2.37 cfs/acre	11.61 cfs
14.28 acres	5%	2.37 cfs/acre	33.84 cfs
Total Q			109.45 cfs

Post-Developed

Area	% impervious	C.I. Factor	Q
20.00 acres	100%	4.75 cfs/acre	95.00 cfs
7.00 acres	5%	2.37 cfs/acre	16.59 cfs
4.90 acres	5%	2.37 cfs/acre	11.61 cfs
5.67 acres	100%	4.75 cfs/acre	26.93 cfs
5.39 acres	5%	2.37 cfs/acre	12.77 cfs
Total Q			162.91 cfs

Flow to Basin:

Area	% impervious	C.I. Factor	Q
20.00 acres	100%	4.75 cfs/acre	95.00 cfs
7.00 acres	5%	2.37 cfs/acre	16.59 cfs
0.87 acres	5%	2.37 cfs/acre	2.06 cfs
Total Q			113.65 cfs



ENGINEERING

PLANNING

SURVEYING

ULTIMATE DEVELOPMENT

Attenuation and Permitted Release Rate Calculations :

EAST Basin 25 year – 20 minute Design Storm

Pre-Developed

Area	% impervious	C.I. Factor	Q
6.75 acres	5%	2.37 cfs/acre	16.00 cfs
10.80 acres	5%	2.37 cfs/acre	25.60 cfs
5.71 acres	5%	2.37 cfs/acre	13.53 cfs
Total Q			55.13 cfs

Post-Developed

Area	% impervious	C.I. Factor	Q
6.75 acres	100%	4.75 cfs/acre	32.06 cfs
10.80 acres	100%	4.75 cfs/acre	51.30 cfs
4.29 acres	100%	4.75 cfs/acre	20.38 cfs
4.64 acres	5%	2.37 cfs/acre	11.00 cfs
Total Q			114.74 cfs

Flow to Basin:

Area	% impervious	C.I. Factor	Q
6.75 acres	100%	4.75 cfs/acre	32.06 cfs
10.80 acres	100%	4.75 cfs/acre	51.30 cfs
2.69 acres	100%	4.75 cfs/acre	12.78 cfs
4.04 acres	5%	2.37 cfs/acre	9.57 cfs
Total Q			105.71 cfs

Required Attenuation:

$$\begin{aligned}
 \text{Attenuation} &= (Q_{\text{post-developed West Basin}} + Q_{\text{post-developed East Basin}}) \\
 &\quad - (Q_{\text{pre-developed West Basin}} + Q_{\text{pre-developed East Basin}}) \\
 &= (162.91 \text{ cfs} + 114.74 \text{ cfs}) - (109.45 \text{ cfs} + 55.13 \text{ cfs})
 \end{aligned}$$

$$\text{Attenuation} = 113.07 \text{ cfs}$$



ENGINEERING

PLANNING

SURVEYING

Permitted Release rate:

$$\begin{aligned} \text{Permitted Release Rate} &= (Q_{\text{in-flow to West Basin}} + Q_{\text{in-flow to East Basin}}) - \text{Attenuation} \\ &= (113.65 \text{ cfs} + 105.71 \text{ cfs}) - 113.07 \text{ cfs} \end{aligned}$$

Permitted Release Rate = 106.29 cfs

ULTIMATE DEVELOPMENT

Storm Water Detention Routing Calculations Summary:

A computer program "PONDPACK" was used in routing the design storm through the basin. Results are attached.

2 year – 20 minute storm:

2 year 20 minute	Inflow to Basin	Peak Release Rate	Peak Elevation	Top of Berm Elevation	Freeboard
West Basin	56.85 cfs	8.55 6.82 cfs	490.38 488.97	495.00 494.50	4.62 5.53 '
East Basin	53.00 cfs	41.17 42.47 cfs	481.76 481.52	485.50	3.74 3.98 '
Total Peak Release Rate		49.57 49.29 cfs			
Allowable Peak Release Rate		50.97 cfs			

15 year – 20 minute storm:

15 year 20 minute	Inflow to Basin	Peak Release Rate	Peak Elevation	Top of Berm Elevation	Freeboard
West Basin	91.70 cfs	9.56 7.77 cfs	491.32 489.84	495.00 494.50	3.68 4.66 '
East Basin	85.50 cfs	65.84 73.17 cfs	482.96 482.84	485.50	2.54 2.66 '
Total Peak Release Rate		75.40 80.94 cfs			
Allowable Peak Release Rate		83.14 cfs			



ENGINEERING

PLANNING

SURVEYING

25 year – 20 minute storm:

25 year 20 minute	Inflow to Basin	Peak Release Rate	Peak Elevation	Top of Berm Elevation	Freeboard
West Basin	113.70 cfs	10.05 8.24 cfs	491.82 490.31	495.00 494.50	3.18 4.19'
East Basin	105.70 cfs	90.25 96.63 cfs	483.34 483.18	485.50	2.16-2.32'
Total Peak Release Rate		100.30 104.87 cfs			
Allowable Peak Release Rate		106.29 cfs			



ENGINEERING

PLANNING

SURVEYING

ULTIMATE DEVELOPMENT

100 YEAR – 20 MINUTE STORM

This storm was routed assuming the low flow culvert is blocked and water has ponded to the top of the overflow structure.

A computer program "PONDPACK" was used in routing the 100 year – 20 minute duration design storm through the basin. Results are attached.

Summary of results are as follows:

West Basin:

Overflow : 50 35' grass spillway (Top of Spillway = ~~494.50~~ 492.50) & Open top 42" inside diameter manhole (Top of Structure = 492.66)

Peak Release Rate: ~~410.46~~ 130.66 cfs

Peak Elevation: ~~493.39~~ 493.50

Top of Berm Elevation: ~~495.00~~ 494.50

East Basin:

Overflow : Open top 48 60" inside diameter manhole (Top of Structure = ~~482.40~~ 482.24)

Peak Release Rate: ~~129.11~~ 130.16 cfs

Peak Elevation: ~~484.46~~ 484.22

Top of Berm Elevation: 485.50



ENGINEERING

PLANNING

SURVEYING

PROPOSED DEVELOPMENT

Attenuation and Permitted Release Rate Calculations:

WEST Basin 2 year – 20 minute Design Storm

Pre-Developed

Area	% impervious	C.I. Factor	Q
20.00 acres	5%	1.15 cfs/acre	23.00 cfs
7.00 acres	5%	1.15 cfs/acre	8.05 cfs
4.90 acres	5%	1.15 cfs/acre	5.64 cfs
14.28 acres	5%	1.15 cfs/acre	16.42 cfs
Total Q			53.11 cfs

Post-Developed

Area	% impervious	C.I. Factor	Q
20.00 acres	5%	1.15 cfs/acre	23.00 cfs
7.00 acres	5%	1.15 cfs/acre	8.05 cfs
4.90 acres	5%	1.15 cfs/acre	5.64 cfs
5.67 acres	100%	2.39 cfs/acre	13.55 cfs
5.39 acres	5%	1.15 cfs/acre	6.20 cfs
Total Q			56.43 cfs

In-Flow to Basin:

Area	% impervious	C.I. Factor	Q
20.00 acres	5%	1.15 cfs/acre	23.00 cfs
7.00 acres	5%	1.15 cfs/acre	8.05 cfs
0.87 acres	5%	1.15 cfs/acre	1.00 cfs
Total Q			32.05 cfs



ENGINEERING

PLANNING

SURVEYING

PROPOSED DEVELOPMENT

Attenuation and Permitted Release Rate Calculations :

EAST Basin 2 year – 20 minute Design Storm

Pre-Developed

Area	% impervious	C.I. Factor	Q
6.75 acres	5%	1.15 cfs/acre	7.76 cfs
10.80 acres	5%	1.15 cfs/acre	12.42 cfs
5.71 acres	5%	1.15 cfs/acre	6.57 cfs
Total Q			26.75 cfs

Post-Developed

Area	% impervious	C.I. Factor	Q
6.75 acres	5%	1.15 cfs/acre	7.76 cfs
10.80 acres	5%	1.15 cfs/acre	12.42 cfs
4.29 acres	100%	2.39 cfs/acre	10.25 cfs
4.64 acres	5%	1.15 cfs/acre	5.34 cfs
Total Q			35.77 cfs

In-Flow to Basin:

Area	% impervious	C.I. Factor	Q
6.75 acres	5%	1.15 cfs/acre	7.76 cfs
10.80 acres	5%	1.15 cfs/acre	12.42 cfs
2.69 acres	100%	2.39 cfs/acre	6.43 cfs
4.04 acres	5%	1.15 cfs/acre	4.65 cfs
Total Q			31.26 cfs

Required Attenuation:

$$\begin{aligned}
 \text{Attenuation} &= (Q_{\text{post-developed West Basin}} + Q_{\text{post-developed East Basin}}) \\
 &\quad - (Q_{\text{pre-developed West Basin}} + Q_{\text{pre-developed East Basin}}) \\
 &= (56.43 \text{ cfs} + 35.77 \text{ cfs}) - (53.11 \text{ cfs} + 26.75 \text{ cfs})
 \end{aligned}$$

$$\text{Attenuation} = 12.34 \text{ cfs}$$



ENGINEERING

PLANNING

SURVEYING

Permitted Release rate:

$$\begin{aligned} \text{Permitted Release Rate} &= (Q_{\text{in-flow to West Basin}} + Q_{\text{in-flow to East Basin}}) - \text{Attenuation} \\ &= (32.05 \text{ cfs} + 31.26 \text{ cfs}) - 12.34 \text{ cfs} \end{aligned}$$

Permitted Release Rate = 50.97 cfs

PROPOSED DEVELOPMENT

Attenuation and Permitted Release Rate Calculations :

WEST Basin 15 year – 20 minute Design Storm

Pre-Developed

Area	% impervious	C.I. Factor	Q
20.00 acres	5%	1.87 cfs/acre	37.40 cfs
7.00 acres	5%	1.87 cfs/acre	13.09 cfs
4.90 acres	5%	1.87 cfs/acre	9.16 cfs
14.28 acres	5%	1.87 cfs/acre	26.70 cfs
Total Q			86.36 cfs

Post-Developed

Area	% impervious	C.I. Factor	Q
20.00 acres	5%	1.87 cfs/acre	37.40 cfs
7.00 acres	5%	1.87 cfs/acre	13.09 cfs
4.90 acres	5%	1.87 cfs/acre	9.16 cfs
5.67 acres	100%	3.85 cfs/acre	21.83 cfs
5.39 acres	5%	1.87 cfs/acre	10.08 cfs
Total Q			91.56 cfs

In-Flow to Basin:

Area	% impervious	C.I. Factor	Q
20.00 acres	5%	1.87 cfs/acre	37.40 cfs
7.00 acres	5%	1.87 cfs/acre	13.09 cfs
0.87 acres	5%	1.87 cfs/acre	1.63 cfs
Total Q			52.12 cfs



ENGINEERING

PLANNING

SURVEYING

PROPOSED DEVELOPMENT

Attenuation and Permitted Release Rate Calculations :

EAST Basin 15 year – 20 minute Design Storm

Pre-Developed

Area	% impervious	C.I. Factor	Q
6.75 acres	5%	1.87 cfs/acre	12.62 cfs
10.80 acres	5%	1.87 cfs/acre	20.20 cfs
5.71 acres	5%	1.87 cfs/acre	10.68 cfs
Total Q			43.50 cfs

Post-Developed

Area	% impervious	C.I. Factor	Q
6.75 acres	5%	1.87 cfs/acre	12.62 cfs
10.80 acres	5%	1.87 cfs/acre	20.20 cfs
4.29 acres	100%	3.85 cfs/acre	16.52 cfs
4.64 acres	5%	1.87 cfs/acre	8.68 cfs
Total Q			58.01 cfs

In-Flow to Basin:

Area	% impervious	C.I. Factor	Q
6.75 acres	5%	1.87 cfs/acre	12.62 cfs
10.80 acres	5%	1.87 cfs/acre	20.20 cfs
2.69 acres	100%	3.85 cfs/acre	10.36 cfs
4.04 acres	5%	1.87 cfs/acre	7.55 cfs
Total Q			50.73 cfs

Required Attenuation:

$$\begin{aligned}
 \text{Attenuation} &= (Q_{\text{post-developed West Basin}} + Q_{\text{post-developed East Basin}}) \\
 &\quad - (Q_{\text{pre-developed West Basin}} + Q_{\text{pre-developed East Basin}}) \\
 &= (91.56 \text{ cfs} + 58.01 \text{ cfs}) - (86.36 \text{ cfs} + 43.50 \text{ cfs})
 \end{aligned}$$

$$\text{Attenuation} = 19.71 \text{ cfs}$$



ENGINEERING

PLANNING

SURVEYING

Permitted Release rate:

$$\begin{aligned} \text{Permitted Release Rate} &= (Q_{\text{in-flow to West Basin}} + Q_{\text{in-flow to East Basin}}) - \text{Attenuation} \\ &= (52.12 \text{ cfs} + 50.73 \text{ cfs}) - 19.71 \text{ cfs} \end{aligned}$$

Permitted Release Rate = 83.14 cfs

PROPOSED DEVELOPMENT

Attenuation and Permitted Release Rate Calculations :

WEST Basin 25 year – 20 minute Design Storm

Pre-Developed

Area	% impervious	C.I. Factor	Q
20.00 acres	5%	2.37 cfs/acre	47.40 cfs
7.00 acres	5%	2.37 cfs/acre	16.59 cfs
4.90 acres	5%	2.37 cfs/acre	11.61 cfs
14.28 acres	5%	2.37 cfs/acre	33.84 cfs
Total Q			109.45 cfs

Post-Developed

Area	% impervious	C.I. Factor	Q
20.00 acres	5%	2.37 cfs/acre	47.40 cfs
7.00 acres	5%	2.37 cfs/acre	16.59 cfs
4.90 acres	5%	2.37 cfs/acre	11.61 cfs
5.67 acres	100%	4.75 cfs/acre	26.93 cfs
5.39 acres	5%	2.37 cfs/acre	12.77 cfs
Total Q			115.31 cfs

In-Flow to Basin:

Area	% impervious	C.I. Factor	Q
20.00 acres	5%	2.37 cfs/acre	47.40 cfs
7.00 acres	5%	2.37 cfs/acre	16.59 cfs
0.87 acres	5%	2.37 cfs/acre	2.06 cfs
Total Q			66.05 cfs



ENGINEERING

PLANNING

SURVEYING

PROPOSED DEVELOPMENT

Attenuation and Permitted Release Rate Calculations :

EAST Basin 25 year – 20 minute Design Storm

Pre-Developed

Area	% impervious	C.I. Factor	Q
6.75 acres	5%	2.37 cfs/acre	16.00 cfs
10.80 acres	5%	2.37 cfs/acre	25.60 cfs
5.71 acres	5%	2.37 cfs/acre	13.53 cfs
Total Q			55.13 cfs

Post-Developed

Area	% impervious	C.I. Factor	Q
6.75 acres	5%	2.37 cfs/acre	16.00 cfs
10.80 acres	5%	2.37 cfs/acre	25.60 cfs
4.29 acres	100%	4.75 cfs/acre	20.38 cfs
4.64 acres	5%	2.37 cfs/acre	11.00 cfs
Total Q			72.97 cfs

In-Flow to Basin:

Area	% impervious	C.I. Factor	Q
6.75 acres	5%	2.37 cfs/acre	16.00 cfs
10.80 acres	5%	2.37 cfs/acre	25.60 cfs
2.69 acres	100%	4.75 cfs/acre	12.78 cfs
4.04 acres	5%	2.37 cfs/acre	9.57 cfs
Total Q			63.95 cfs

Required Attenuation:

$$\begin{aligned}
 \text{Attenuation} &= (Q_{\text{post-developed West Basin}} + Q_{\text{post-developed East Basin}}) \\
 &\quad - (Q_{\text{pre-developed West Basin}} + Q_{\text{pre-developed East Basin}}) \\
 &= (115.31 \text{ cfs} + 72.97 \text{ cfs}) - (109.45 \text{ cfs} + 55.13 \text{ cfs})
 \end{aligned}$$

$$\text{Attenuation} = \mathbf{23.70 \text{ cfs}}$$



ENGINEERING

PLANNING

SURVEYING

Permitted Release rate:

$$\begin{aligned} \text{Permitted Release Rate} &= (Q_{\text{in-flow to West Basin}} + Q_{\text{in-flow to East Basin}}) - \text{Attenuation} \\ &= (66.05 \text{ cfs} + 63.95 \text{ cfs}) - 23.70 \text{ cfs} \end{aligned}$$

Permitted Release Rate = 106.30 cfs

PROPOSED DEVELOPMENT

Storm Water Detention Routing Calculations Summary:

A computer program "PONDPACK" was used in routing the design storm through the basin. Results are attached.

2 year – 20 minute storm:

2 year	Inflow	Peak Release	Peak	Top of Berm	Freeboard
20 minute	to Basin	Rate	Elevation	Elevation	
West Basin	32.05 cfs	7.48 5.85 cfs	489.48 488.19	495.00 494.50	5.52 6.31'
East Basin	31.26 cfs	30.08 30.96 cfs	480.95 480.19	485.50	4.55 5.31'
Total Peak Release Rate		38.56 36.81 cfs			
Allowable Peak Release Rate		50.97 cfs			

15 year – 20 minute storm:

15 year	Inflow	Peak Release	Peak	Top of Berm	Freeboard
20 minute	to Basin	Rate	Elevation	Elevation	
West Basin	52.12 cfs	8.37 6.66 cfs	490.23 488.83	495.00 494.50	4.77 5.67'
East Basin	50.73 cfs	40.13 41.46 cfs	481.65 481.38	485.50	3.85 4.12'
Total Peak Release Rate		49.29 48.12 cfs			
Allowable Peak Release Rate		83.14 cfs			



ENGINEERING
 PLANNING
 SURVEYING

25 year – 20 minute storm:

25 year 20 minute	Inflow to Basin	Peak Release Rate	Peak Elevation	Top of Berm Elevation	Freeboard
West Basin	66.10 cfs	8.88 7.11 cfs	490.65 489.22	495.00 494.50	4.35 5.28'
East Basin	63.95 cfs	45.22 46.92 cfs	482.23 482.14	485.50	3.27 3.36'
Total Peak Release Rate		54.10 54.03 cfs			
Allowable Peak Release Rate		106.30 cfs			

PROPOSED DEVELOPMENT

100 YEAR – 20 MINUTE STORM

This storm was routed assuming the low flow culvert is blocked and water has ponded to the top of the overflow structure or spillway.

A computer program "PONDPACK" was used in routing the 100 year – 20 minute duration design storm through the basin. Results are attached.

Summary of results are as follows:

West Basin:

Overflow : 50 35' grass spillway (Top of Spillway = 48.50 492.50) & Open top 42" inside diameter manhole (Top of Structure = 492.66)

Peak Release Rate: ~~64.68~~ 70.84 cfs

Peak Elevation: ~~493.11~~ 493.18

Top of Berm Elevation: 495.00 494.50

East Basin:

Overflow : Open top 72 60" inside diameter manhole (Top of Structure = 482.50 482.24)

Peak Release Rate: ~~75.03~~ 77.02 cfs

Peak Elevation: ~~483.04~~ 483.63

Top of Berm Elevation: 485.0 485.50



ENGINEERING

PLANNING

SURVEYING

West Detention Basin Characteristics:

Outfall: 42" inside diameter manhole
10" wide x 12" tall slot at base of structure (Flowline = ~~486.00~~
485.55)
Elevation of Structure Top = ~~494.00~~ 492.66
Structure shall be installed with a web of safety bars across the top.

Top of Basin Elevation: ~~495.00~~ 494.50

East Detention Basin Characteristics:

Outfall: 72 60" inside diameter manhole
21" wide x 36" high slot at base of structure (Flowline = ~~478.00~~
477.19)
Elevation of Structure Top = ~~482.50~~ 482.24

Manhole shall be installed with a web of safety bars across the open top along with an anti vortex device

Top of Basin Elevation: 485.50

STRUCTURES

1/4" METAL PLATE ANTI-VORTEX
DEVICE INSTALL PERPENDICULAR
TO DAM.
6 #4 BARS

#4 BARS AT 6" CENTERS

SILL = 482.24 - MODIFIED

~~SILL = 481.74~~

~~SILL = 482.50~~

~~Top of Slot = 481.00~~

Top of Slot = 480.19

~~21" W X 36" H Pre-Cast Slot~~

21" W X 36" H Pre-Cast Slot

SILL = 477.19

~~SILL = 478.00~~

60" (inside diameter) PRECAST
CONCRETE MANHOLE STRUCTURE

EAST BASIN OVERFLOW STRUCTURE # 213 DETAIL

NOT TO SCALE

#4 BARS AT 6" CENTERS

42" (inside diameter) PRECAST
CONCRETE MANHOLE STRUCTURE

SILL = 492.66
~~SILL = 494.00~~

Top of Slot = 486.55
~~Top of Slot = 487.00~~

~~10" W X 12" H Pre-Cast SLOT~~
10" W X 12" H Pre-Cast SLOT

~~SILL = 486.00~~
SILL = 485.55

WEST BASIN OVERFLOW STRUCTURE # 207 DETAIL

NOT TO SCALE

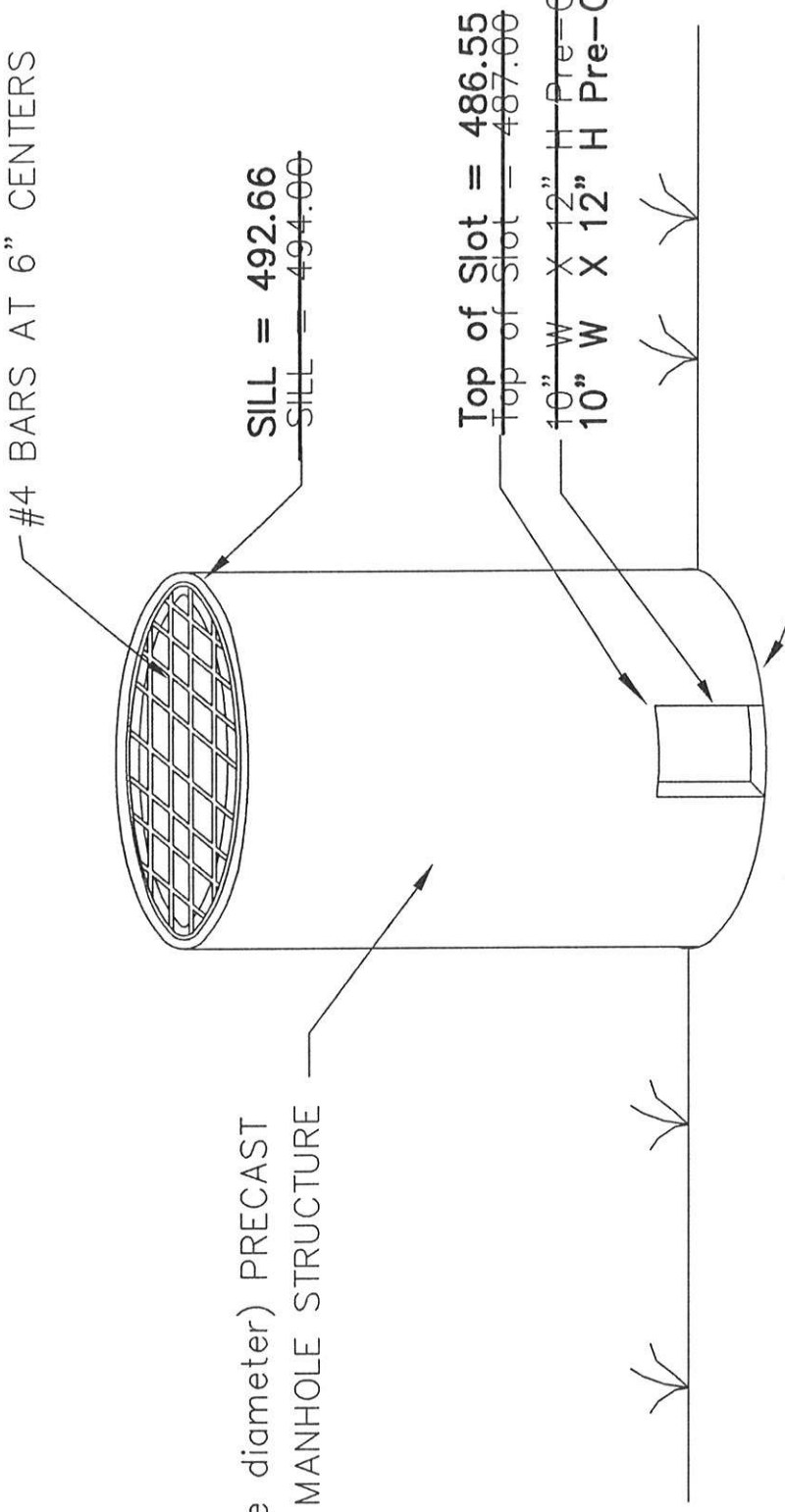

STORMWATER DETENTION CALCULATIONS

ULTIMATE DEVELOPMENT

WEST BASIN

Table of Contents

***** NETWORK SUMMARIES (DETAILED) *****

Watershed..... 2
 Executive Summary (Nodes) 1.01

Watershed..... 15
 Executive Summary (Nodes) 1.02

Watershed..... 25
 Executive Summary (Nodes) 1.03

***** TIME VS.ELEV *****

WEST OUT 2
 Time-Elev 2.01

WEST OUT 15
 Time-Elev 2.03

WEST OUT 25
 Time-Elev 2.05

***** TIME VS.VOL *****

WEST OUT 2
 Time vs. Volume 3.01

WEST OUT 15
 Time vs. Volume 3.03

WEST OUT 25
 Time vs. Volume 3.05

***** POND VOLUMES *****

WEST..... Vol: Planimeter 4.01

Table of Contents

***** OUTLET STRUCTURES *****

WEST MODIFIED...	Outlet Input Data	5.01
	Composite Rating Curve	5.04

***** POND ROUTING *****

WEST.....	Pond E-V-Q Table	6.01
WEST	IN 2 Node: Pond Inflow Summary	6.06
WEST	IN 15 Node: Pond Inflow Summary	6.08
WEST	IN 25 Node: Pond Inflow Summary	6.10
WEST	OUT 2 Pond Routing Summary	6.12
WEST	OUT 15 Pond Routing Summary	6.13
WEST	OUT 25 Pond Routing Summary	6.14

Table of Contents (continued)

NETWORK SUMMARY -- NODES

(Trun.= HYG Truncation: Blank=None; L=Left; R=Rt; LR=Left & Rt)

Node ID	Type	HYG Vol cu.ft	Trun.	Qpeak min	Qpeak cfs	Max WSEL ft
Outfall EAST	HYG	63605		12.00	53.00	
EAST	JCT	63605		22.00	42.47	
Outfall EAST	IN POND	63605		12.00	53.00	
EAST	OUT POND	63605		22.00	42.47	481.52
Outfall WEST	HYG	68218		8.00	56.85	
WEST	JCT	68218		27.00	6.82	
Outfall WEST	IN POND	68218		8.00	56.85	
WEST	OUT POND	68218		27.00	6.82	488.97

NETWORK SUMMARY -- NODES

(Trun.= HYG Truncation: Blank=None; L=Left; R=Rt; LR=Left & Rt)

Node ID	Type	HYG Vol cu.ft	Trun.	Qpeak min	Qpeak cfs	Max WSEL ft
EAST	HYG	102600		12.00	85.50	
Outfall EAST	JCT	102600		22.00	73.17	
EAST	IN POND	102600		12.00	85.50	
EAST	OUT POND	102600		22.00	73.17	482.84
WEST	HYG	110045		8.00	91.70	
Outfall WEST	JCT	110045		27.00	7.77	
WEST	IN POND	110045		8.00	91.70	
WEST	OUT POND	110045		27.00	7.77	489.84

NETWORK SUMMARY -- NODES

(Trun.= HYG Truncation: Blank=None; L=Left; R=Rt; LR=Left & Rt)

Node ID	Type	HYG Vol cu.ft	Trun.	Qpeak min	Qpeak cfs	Max WSEL ft
EAST	HYG	126836		12.00	105.70	
Outfall EAST	JCT	126836		21.00	96.63	
EAST	IN POND	126836		12.00	105.70	
EAST	OUT POND	126836		21.00	96.63	483.18
WEST	HYG	136445		8.00	113.70	
Outfall WEST	JCT	136445		27.00	8.24	
WEST	IN POND	136445		8.00	113.70	
WEST	OUT POND	136445		27.00	8.24	490.31

TIME vs. ELEVATION (ft)

Output Time increment = 1.00 min
 Time on left represents time for first value in each row.

Time min					
.00	485.55	486.03	486.31	486.55	486.76
5.00	486.95	487.14	487.31	487.48	487.63
10.00	487.76	487.88	487.99	488.09	488.18
15.00	488.28	488.37	488.45	488.54	488.62
20.00	488.70	488.77	488.83	488.88	488.92
25.00	488.95	488.96	488.97	488.96	488.95
30.00	488.94	488.93	488.92	488.91	488.90
35.00	488.89	488.88	488.87	488.86	488.85
40.00	488.84	488.83	488.82	488.81	488.80
45.00	488.79	488.78	488.77	488.76	488.75
50.00	488.74	488.73	488.72	488.71	488.70
55.00	488.69	488.68	488.67	488.66	488.65
60.00	488.64	488.63	488.62	488.61	488.60
65.00	488.59	488.58	488.57	488.56	488.55
70.00	488.54	488.52	488.51	488.50	488.49
75.00	488.48	488.47	488.46	488.45	488.44
80.00	488.43	488.42	488.41	488.40	488.39
85.00	488.38	488.37	488.36	488.35	488.34
90.00	488.32	488.31	488.30	488.29	488.28
95.00	488.27	488.26	488.25	488.24	488.23
100.00	488.22	488.21	488.20	488.19	488.18
105.00	488.16	488.15	488.14	488.13	488.12
110.00	488.11	488.10	488.09	488.08	488.07
115.00	488.06	488.05	488.03	488.02	488.01
120.00	488.00	487.99	487.98	487.97	487.96
125.00	487.95	487.93	487.92	487.91	487.90
130.00	487.89	487.88	487.86	487.85	487.84
135.00	487.83	487.82	487.80	487.79	487.78
140.00	487.77	487.76	487.74	487.73	487.72
145.00	487.70	487.69	487.68	487.66	487.65
150.00	487.64	487.62	487.61	487.60	487.58
155.00	487.57	487.55	487.54	487.52	487.51
160.00	487.49	487.48	487.46	487.45	487.43
165.00	487.42	487.40	487.39	487.37	487.35
170.00	487.34	487.32	487.30	487.29	487.27
175.00	487.25	487.23	487.21	487.20	487.18
180.00	487.16	487.14	487.12	487.10	487.08
185.00	487.06	487.04	487.02	486.99	486.97
190.00	486.95	486.93	486.90	486.88	486.86
195.00	486.83	486.80	486.78	486.75	486.72
200.00	486.70	486.67	486.64	486.61	486.57
205.00	486.54	486.51	486.48	486.45	486.41
210.00	486.38	486.35	486.32	486.28	486.25

TIME vs. ELEVATION (ft)

Time min	Output Time increment = 1.00 min				
	Time on left represents time for first value in each row.				
215.00	486.21	486.18	486.14	486.10	486.06
220.00	486.02	485.97	485.93	485.88	485.83
225.00	485.77	485.70	485.62	485.55	

TIME vs. ELEVATION (ft)

Time min	Output Time increment = 1.00 min				
	Time on left represents time for first value in each row.				
.00	485.55	486.11	486.45	486.73	486.98
5.00	487.21	487.43	487.64	487.84	488.02
10.00	488.18	488.34	488.48	488.62	488.76
15.00	488.89	489.01	489.13	489.25	489.36
20.00	489.47	489.56	489.64	489.71	489.76
25.00	489.80	489.82	489.84	489.83	489.82
30.00	489.82	489.81	489.80	489.79	489.78
35.00	489.77	489.76	489.75	489.74	489.73
40.00	489.73	489.72	489.71	489.70	489.69
45.00	489.68	489.67	489.66	489.65	489.64
50.00	489.63	489.63	489.62	489.61	489.60
55.00	489.59	489.58	489.57	489.56	489.55
60.00	489.54	489.53	489.52	489.51	489.51
65.00	489.50	489.49	489.48	489.47	489.46
70.00	489.45	489.44	489.43	489.42	489.41
75.00	489.40	489.39	489.38	489.37	489.36
80.00	489.36	489.35	489.34	489.33	489.32
85.00	489.31	489.30	489.29	489.28	489.27
90.00	489.26	489.25	489.24	489.23	489.22
95.00	489.21	489.20	489.19	489.18	489.17
100.00	489.16	489.15	489.14	489.13	489.13
105.00	489.12	489.11	489.10	489.09	489.08
110.00	489.07	489.06	489.05	489.04	489.03
115.00	489.02	489.01	489.00	488.99	488.98
120.00	488.97	488.96	488.95	488.94	488.93
125.00	488.92	488.91	488.90	488.89	488.88
130.00	488.87	488.86	488.85	488.84	488.83
135.00	488.82	488.81	488.80	488.79	488.78
140.00	488.77	488.76	488.75	488.74	488.73
145.00	488.72	488.71	488.70	488.69	488.68
150.00	488.67	488.66	488.65	488.63	488.62
155.00	488.61	488.60	488.59	488.58	488.57
160.00	488.56	488.55	488.54	488.53	488.52
165.00	488.51	488.50	488.49	488.48	488.47
170.00	488.46	488.45	488.44	488.43	488.42
175.00	488.41	488.40	488.38	488.37	488.36
180.00	488.35	488.34	488.33	488.32	488.31
185.00	488.30	488.29	488.28	488.27	488.26
190.00	488.25	488.24	488.22	488.21	488.20
195.00	488.19	488.18	488.17	488.16	488.15
200.00	488.14	488.13	488.12	488.11	488.10
205.00	488.08	488.07	488.06	488.05	488.04
210.00	488.03	488.02	488.01	488.00	487.99

TIME vs. ELEVATION (ft)

Time min	Output Time increment = 1.00 min				
	Time on left represents time for first value in each row.				
215.00	487.98	487.96	487.95	487.94	487.93
220.00	487.92	487.91	487.90	487.88	487.87
225.00	487.86	487.85	487.84	487.82	487.81
230.00	487.80	487.79	487.78	487.76	487.75
235.00	487.74	487.72	487.71	487.70	487.69
240.00	487.67	487.66	487.65	487.63	487.62
245.00	487.60	487.59	487.58	487.56	487.55
250.00	487.53	487.52	487.50	487.49	487.47
255.00	487.46	487.44	487.43	487.41	487.40
260.00	487.38	487.36	487.35	487.33	487.31
265.00	487.30	487.28	487.26	487.24	487.23
270.00	487.21	487.19	487.17	487.15	487.13
275.00	487.11	487.09	487.07	487.05	487.03
280.00	487.01	486.99	486.97	486.94	486.92
285.00	486.89	486.87	486.85	486.82	486.79
290.00	486.77	486.74	486.71	486.69	486.66
295.00	486.63	486.59	486.56	486.53	486.50
300.00	486.47	486.43	486.40	486.37	486.34
305.00	486.30	486.27	486.24	486.20	486.16
310.00	486.13	486.08	486.05	486.00	485.96
315.00	485.91	485.86	485.80	485.75	485.67
320.00	485.57	485.55			

TIME vs. ELEVATION (ft)

Time min	Output Time increment = 1.00 min				
	Time on left represents time for first value in each row.				
.00	485.55	486.16	486.52	486.82	487.09
5.00	487.35	487.58	487.80	488.02	488.22
10.00	488.41	488.59	488.76	488.92	489.08
15.00	489.22	489.36	489.50	489.63	489.76
20.00	489.88	489.99	490.08	490.16	490.22
25.00	490.26	490.29	490.31	490.31	490.30
30.00	490.29	490.28	490.27	490.26	490.25
35.00	490.24	490.23	490.23	490.22	490.21
40.00	490.20	490.19	490.18	490.17	490.16
45.00	490.16	490.15	490.14	490.13	490.12
50.00	490.11	490.10	490.09	490.09	490.08
55.00	490.07	490.06	490.05	490.04	490.03
60.00	490.02	490.02	490.01	490.00	489.99
65.00	489.98	489.97	489.96	489.95	489.95
70.00	489.94	489.93	489.92	489.91	489.90
75.00	489.89	489.88	489.87	489.87	489.86
80.00	489.85	489.84	489.83	489.82	489.81
85.00	489.80	489.79	489.79	489.78	489.77
90.00	489.76	489.75	489.74	489.73	489.72
95.00	489.71	489.70	489.70	489.69	489.68
100.00	489.67	489.66	489.65	489.64	489.63
105.00	489.62	489.61	489.60	489.59	489.59
110.00	489.58	489.57	489.56	489.55	489.54
115.00	489.53	489.52	489.51	489.50	489.49
120.00	489.48	489.47	489.47	489.46	489.45
125.00	489.44	489.43	489.42	489.41	489.40
130.00	489.39	489.38	489.37	489.36	489.35
135.00	489.34	489.33	489.32	489.31	489.31
140.00	489.30	489.29	489.28	489.27	489.26
145.00	489.25	489.24	489.23	489.22	489.21
150.00	489.20	489.19	489.18	489.17	489.16
155.00	489.15	489.14	489.13	489.12	489.11
160.00	489.10	489.09	489.08	489.07	489.06
165.00	489.05	489.04	489.03	489.02	489.01
170.00	489.00	488.99	488.98	488.98	488.97
175.00	488.96	488.95	488.94	488.93	488.92
180.00	488.91	488.90	488.89	488.88	488.87
185.00	488.86	488.85	488.84	488.83	488.82
190.00	488.81	488.79	488.78	488.77	488.76
195.00	488.75	488.74	488.73	488.72	488.71
200.00	488.70	488.69	488.68	488.67	488.66
205.00	488.65	488.64	488.63	488.62	488.61
210.00	488.60	488.59	488.58	488.57	488.56

TIME vs. ELEVATION (ft)

Time min	Output Time increment = 1.00 min				
	Time on left represents time for first value in each row.				
215.00	488.55	488.54	488.53	488.52	488.51
220.00	488.50	488.49	488.48	488.47	488.46
225.00	488.44	488.43	488.42	488.41	488.40
230.00	488.39	488.38	488.37	488.36	488.35
235.00	488.34	488.33	488.32	488.31	488.30
240.00	488.29	488.28	488.26	488.25	488.24
245.00	488.23	488.22	488.21	488.20	488.19
250.00	488.18	488.17	488.16	488.15	488.14
255.00	488.12	488.11	488.10	488.09	488.08
260.00	488.07	488.06	488.05	488.04	488.03
265.00	488.02	488.00	487.99	487.98	487.97
270.00	487.96	487.95	487.94	487.93	487.91
275.00	487.90	487.89	487.88	487.87	487.86
280.00	487.85	487.83	487.82	487.81	487.80
285.00	487.78	487.77	487.76	487.75	487.73
290.00	487.72	487.71	487.69	487.68	487.67
295.00	487.66	487.64	487.63	487.61	487.60
300.00	487.59	487.57	487.56	487.54	487.53
305.00	487.51	487.50	487.48	487.47	487.45
310.00	487.44	487.42	487.41	487.39	487.38
315.00	487.36	487.34	487.33	487.31	487.29
320.00	487.27	487.26	487.24	487.22	487.20
325.00	487.18	487.17	487.15	487.13	487.11
330.00	487.09	487.07	487.05	487.02	487.00
335.00	486.98	486.96	486.94	486.91	486.89
340.00	486.86	486.84	486.81	486.79	486.76
345.00	486.73	486.71	486.68	486.65	486.62
350.00	486.58	486.55	486.52	486.49	486.46
355.00	486.42	486.39	486.36	486.33	486.29
360.00	486.26	486.22	486.19	486.15	486.11
365.00	486.07	486.03	485.99	485.95	485.89
370.00	485.85	485.79	485.73	485.66	485.55

TIME vs. VOLUME (cu.ft)

Output Time increment = 1.00 min
Time on left represents time for first value in each row.

Time min					
.00	0	184	745	1685	2989
5.00	4695	6795	9294	12214	15336
10.00	18441	21521	24607	27690	30755
15.00	33814	36867	39915	42947	45970
20.00	48992	51801	54177	56116	57629
25.00	58725	59379	59607	59413	59009
30.00	58598	58187	57777	57369	56963
35.00	56559	56157	55757	55359	54962
40.00	54558	54154	53750	53350	52952
45.00	52555	52160	51766	51375	50986
50.00	50589	50192	49797	49404	49013
55.00	48623	48236	47851	47468	47085
60.00	46694	46305	45917	45533	45149
65.00	44768	44389	44011	43637	43258
70.00	42875	42494	42115	41738	41363
75.00	40991	40619	40250	39883	39509
80.00	39135	38763	38392	38024	37658
85.00	37293	36932	36572	36209	35842
90.00	35477	35113	34752	34393	34036
95.00	33681	33328	32977	32617	32259
100.00	31903	31549	31197	30847	30500
105.00	30155	29811	29462	29111	28764
110.00	28417	28073	27731	27391	27054
115.00	26718	26378	26034	25692	25352
120.00	25013	24678	24347	24020	23697
125.00	23369	23027	22691	22359	22031
130.00	21708	21389	21073	20762	20435
135.00	20105	19779	19459	19142	18830
140.00	18524	18221	17906	17585	17268
145.00	16957	16650	16349	16052	15760
150.00	15447	15136	14832	14533	14239
155.00	13951	13667	13368	13067	12772
160.00	12483	12199	11922	11650	11354
165.00	11065	10783	10507	10238	9975
170.00	9696	9416	9143	8878	8619
175.00	8368	8095	7828	7569	7318
180.00	7075	6823	6564	6315	6074
185.00	5842	5601	5356	5120	4893
190.00	4676	4439	4211	3994	3788
195.00	3569	3353	3150	2958	2750
200.00	2552	2368	2184	1996	1824
205.00	1660	1493	1350	1225	1093
210.00	977	875	764	667	584

TIME vs. VOLUME (cu.ft)

Output Time increment = 1.00 min
Time on left represents time for first value in each row.

Time min	493	417	350	281	227
215.00	493	417	350	281	227
220.00	174	130	93	60	36
225.00	18	6	0	0	

TIME vs. VOLUME (cu.ft)

Time min	Output Time increment = 1.00 min				
	Time on left represents time for first value in each row.				
.00	0	306	1247	2795	4981
5.00	7828	11346	15529	20374	25542
10.00	30707	35858	40986	46111	51231
15.00	56323	61417	66508	71593	76661
20.00	81720	86432	90456	93769	96413
25.00	98348	99606	100177	100052	99584
30.00	99116	98650	98185	97722	97261
35.00	96802	96344	95887	95424	94960
40.00	94495	94034	93574	93116	92659
45.00	92203	91750	91299	90848	90392
50.00	89932	89476	89021	88566	88114
55.00	87665	87216	86769	86324	85880
60.00	85429	84977	84526	84078	83631
65.00	83185	82741	82299	81859	81420
70.00	80983	80536	80091	79648	79206
75.00	78766	78328	77891	77456	77023
80.00	76592	76157	75717	75280	74843
85.00	74409	73977	73545	73117	72689
90.00	72263	71840	71406	70975	70543
95.00	70116	69689	69264	68841	68419
100.00	68000	67582	67160	66733	66309
105.00	65886	65466	65047	64630	64215
110.00	63802	63391	62977	62557	62140
115.00	61724	61310	60898	60488	60079
120.00	59672	59268	58864	58450	58040
125.00	57630	57223	56818	56415	56013
130.00	55613	55216	54818	54412	54008
135.00	53607	53207	52809	52412	52018
140.00	51626	51235	50845	50446	50050
145.00	49655	49263	48872	48484	48097
150.00	47713	47330	46944	46554	46166
155.00	45779	45394	45012	44631	44253
160.00	43877	43502	43120	42737	42358
165.00	41979	41603	41229	40857	40487
170.00	40118	39751	39374	39001	38629
175.00	38259	37893	37527	37164	36801
180.00	36443	36077	35710	35345	34983
185.00	34623	34264	33908	33553	33201
190.00	32847	32488	32131	31776	31423
195.00	31071	30722	30376	30030	29687
200.00	29336	28986	28638	28293	27950
205.00	27608	27270	26933	26598	26254
210.00	25910	25569	25230	24893	24559

TIME vs. VOLUME (cu.ft)

Time min	Output Time increment = 1.00 min				
	Time on left represents time for first value in each row.				
215.00	24229	23903	23582	23246	22906
220.00	22571	22241	21915	21592	21274
225.00	20961	20649	20316	19987	19664
230.00	19345	19030	18719	18414	18113
235.00	17790	17470	17155	16846	16541
240.00	16241	15947	15648	15334	15026
245.00	14724	14427	14135	13849	13564
250.00	13259	12960	12667	12380	12099
255.00	11824	11543	11250	10963	10683
260.00	10410	10142	9878	9594	9317
265.00	9047	8784	8528	8271	7998
270.00	7734	7478	7230	6989	6729
275.00	6473	6227	5990	5760	5512
280.00	5269	5037	4814	4591	4356
285.00	4132	3919	3714	3490	3278
290.00	3079	2884	2677	2484	2305
295.00	2115	1932	1765	1597	1439
300.00	1304	1176	1050	939	834
305.00	727	636	550	464	393
310.00	323	260	210	156	117
315.00	79	52	28	14	3
320.00	0	0			

TIME vs. VOLUME (cu.ft)

Time min	Output Time increment = 1.00 min				
	Time on left represents time for first value in each row.				
.00	0	388	1545	3491	6242
5.00	9837	14224	19453	25534	32018
10.00	38478	44923	51366	57781	64193
15.00	70592	76987	83360	89739	96109
20.00	102458	108383	113454	117664	121009
25.00	123506	125142	125927	125859	125366
30.00	124872	124380	123888	123397	122908
35.00	122415	121924	121432	120941	120452
40.00	119964	119476	118988	118503	118017
45.00	117533	117048	116562	116075	115591
50.00	115108	114624	114141	113660	113180
55.00	112701	112222	111744	111262	110781
60.00	110301	109821	109342	108865	108389
65.00	107915	107442	106970	106501	106026
70.00	105548	105072	104597	104125	103654
75.00	103184	102716	102249	101784	101321
80.00	100856	100384	99915	99445	98978
85.00	98512	98049	97587	97125	96667
90.00	96209	95753	95287	94823	94359
95.00	93899	93439	92981	92524	92070
100.00	91617	91165	90716	90257	89798
105.00	89341	88887	88434	87982	87531
110.00	87083	86638	86193	85748	85296
115.00	84844	84393	83946	83499	83053
120.00	82610	82170	81730	81292	80852
125.00	80406	79960	79516	79077	78636
130.00	78199	77762	77328	76896	76465
135.00	76027	75589	75150	74715	74282
140.00	73849	73419	72990	72563	72138
145.00	71712	71278	70847	70417	69989
150.00	69562	69139	68716	68295	67876
155.00	67458	67034	66607	66184	65763
160.00	65343	64924	64508	64094	63681
165.00	63269	62854	62434	62017	61602
170.00	61189	60776	60366	59959	59553
175.00	59149	58741	58329	57919	57510
180.00	57103	56698	56296	55894	55496
185.00	55099	54698	54293	53890	53488
190.00	53089	52691	52296	51902	51511
195.00	51120	50726	50329	49933	49539
200.00	49147	48757	48370	47984	47599
205.00	47217	46828	46439	46051	45665
210.00	45281	44900	44519	44142	43765

TIME vs. VOLUME (cu.ft)

Time min	Output Time increment = 1.00 min				
	Time on left represents time for first value in each row.				
215.00	43390	43007	42625	42245	41868
220.00	41493	41119	40748	40378	40010
225.00	39639	39264	38890	38519	38151
230.00	37784	37419	37056	36695	36337
235.00	35968	35603	35239	34877	34517
240.00	34159	33803	33449	33098	32741
245.00	32383	32025	31670	31319	30968
250.00	30620	30273	29929	29584	29232
255.00	28883	28536	28192	27849	27508
260.00	27170	26833	26498	26153	25809
265.00	25469	25130	24794	24461	24133
270.00	23808	23488	23145	22807	22473
275.00	22144	21819	21498	21181	20869
280.00	20551	20219	19891	19569	19251
285.00	18938	18629	18325	18018	17695
290.00	17376	17064	16755	16452	16154
295.00	15860	15555	15243	14937	14635
300.00	14340	14050	13765	13473	13170
305.00	12873	12582	12297	12017	11743
310.00	11455	11164	10880	10602	10330
315.00	10065	9794	9511	9237	8969
320.00	8708	8454	8189	7920	7658
325.00	7404	7158	6914	6653	6400
330.00	6156	5921	5689	5439	5200
335.00	4971	4750	4521	4289	4068
340.00	3858	3646	3426	3218	3023
345.00	2821	2619	2430	2253	2059
350.00	1881	1719	1547	1397	1268
355.00	1136	1015	909	801	698
360.00	611	522	441	375	303
365.00	244	192	143	108	70
370.00	46	22	9	2	0

POND VOLUME CALCULATIONS

Planimeter scale: 1.00 ft/in

Elevation (ft)	Planimeter (sq.in)	Area (sq.ft)	A1+A2+sqr(A1*A2) (sq.ft)	Volume (cu.ft)	Volume Sum (cu.ft)
485.55	.000	0	0	0	0
488.00	30596.000	30596	30596	24987	24987
490.00	54535.000	54535	125979	83986	108973
492.00	65189.000	65189	179349	119566	228539
494.00	74425.000	74425	209268	139512	368051
495.00	78785.000	78785	229784	76595	444645

POND VOLUME EQUATIONS

* Incremental volume computed by the Conic Method for Reservoir Volumes.

$$\text{Volume} = (1/3) * (\text{EL2}-\text{EL1}) * (\text{Area1} + \text{Area2} + \text{sq.rt.}(\text{Area1}*\text{Area2}))$$

where: EL1, EL2 = Lower and upper elevations of the increment
Area1, Area2 = Areas computed for EL1, EL2, respectively
Volume = Incremental volume between EL1 and EL2

REQUESTED POND WS ELEVATIONS:

Min. Elev.= 485.55 ft
Increment = .10 ft
Max. Elev.= 495.00 ft

OUTLET CONNECTIVITY

---> Forward Flow Only (UpStream to DnStream)
<--- Reverse Flow Only (DnStream to UpStream)
<---> Forward and Reverse Both Allowed

Structure	No.		Outfall	E1, ft	E2, ft
-----	-----		-----	-----	-----
Weir-Rectangular	W0	--->	TW	485.550	486.550
Weir-Rectangular	W1	--->	TW	492.500	495.000
Stand Pipe	R0	--->	TW	492.660	495.000
Orifice-Area	O0	--->	TW	486.550	495.000
TW SETUP, DS Channel					

Type.... Outlet Input Data
Name.... WEST MODIFIED

File.... H:\PONDPACK\9000PLUS\9203F-DATA\AS-BUILT ULTIMATE PHASE.MODIFIED BASIN.04.17.2006

OUTLET STRUCTURE INPUT DATA

Structure ID = W0
Structure Type = Weir-Rectangular

of Openings = 1
Crest Elev. = 485.55 ft
Weir Length = .83 ft
Weir Coeff. = 3.000000

Weir TW effects (Use adjustment equation)

Structure ID = W1
Structure Type = Weir-Rectangular

of Openings = 1
Crest Elev. = 492.50 ft
Weir Length = 35.00 ft
Weir Coeff. = 3.000000

Weir TW effects (Use adjustment equation)

OUTLET STRUCTURE INPUT DATA

Structure ID = R0
Structure Type = Stand Pipe

of Openings = 1
Invert Elev. = 492.66 ft
Diameter = 3.5000 ft
Orifice Area = 9.6211 sq.ft
Orifice Coeff. = .600
Weir Length = 11.00 ft
Weir Coeff. = 3.000
K, Reverse = 1.000
Mannings n = .0000
Kev, Charged Riser = .000
Weir Submergence = No
Orifice H to crest = Yes

Structure ID = 00
Structure Type = Orifice-Area

of Openings = 1
Invert Elev. = 485.55 ft
Area = .8300 sq.ft
Top of Orifice = 486.55 ft
Datum Elev. = 486.05 ft
Orifice Coeff. = .600

Structure ID = TW
Structure Type = TW SETUP, DS Channel

FREE OUTFALL CONDITIONS SPECIFIED

CONVERGENCE TOLERANCES...
Maximum Iterations = 40
Min. TW tolerance = .01 ft
Max. TW tolerance = .01 ft
Min. HW tolerance = .01 ft
Max. HW tolerance = .01 ft
Min. Q tolerance = .00 cfs
Max. Q tolerance = .00 cfs

***** COMPOSITE OUTFLOW SUMMARY *****

WS Elev, Total Q		Converge		Notes
Elev.	Q	TW Elev	Error	Contributing Structures
ft	cfs	ft	+/-ft	
485.55	.00	Free	Outfall	W0
485.65	.08	Free	Outfall	W0
485.75	.22	Free	Outfall	W0
485.85	.41	Free	Outfall	W0
485.95	.63	Free	Outfall	W0
486.05	.88	Free	Outfall	W0
486.15	1.16	Free	Outfall	W0
486.25	1.46	Free	Outfall	W0
486.35	1.78	Free	Outfall	W0
486.45	2.13	Free	Outfall	W0
486.55	2.82	Free	Outfall	00
486.65	3.09	Free	Outfall	00
486.75	3.34	Free	Outfall	00
486.85	3.57	Free	Outfall	00
486.95	3.79	Free	Outfall	00
487.05	3.99	Free	Outfall	00
487.15	4.19	Free	Outfall	00
487.25	4.38	Free	Outfall	00
487.35	4.55	Free	Outfall	00
487.45	4.73	Free	Outfall	00
487.55	4.89	Free	Outfall	00
487.65	5.05	Free	Outfall	00
487.75	5.21	Free	Outfall	00
487.85	5.36	Free	Outfall	00
487.95	5.51	Free	Outfall	00
488.05	5.65	Free	Outfall	00
488.15	5.79	Free	Outfall	00
488.25	5.93	Free	Outfall	00
488.35	6.06	Free	Outfall	00
488.45	6.19	Free	Outfall	00
488.55	6.32	Free	Outfall	00
488.65	6.44	Free	Outfall	00
488.75	6.56	Free	Outfall	00
488.85	6.68	Free	Outfall	00
488.95	6.80	Free	Outfall	00
489.05	6.92	Free	Outfall	00
489.15	7.03	Free	Outfall	00
489.25	7.15	Free	Outfall	00

Name.... WEST MODIFIED

File.... H:\PONDPACK\9000PLUS\9203F-DATA\AS-BUILT ULTIMATE PHASE.MODIFIED BASIN.04.17.2006

***** COMPOSITE OUTFLOW SUMMARY *****

WS Elev, Total Q		Converge		Notes
Elev. ft	Q cfs	TW Elev ft	Error +/-ft	Contributing Structures
489.35	7.26	Free	Outfall	00
489.45	7.37	Free	Outfall	00
489.55	7.47	Free	Outfall	00
489.65	7.58	Free	Outfall	00
489.75	7.68	Free	Outfall	00
489.85	7.79	Free	Outfall	00
489.95	7.89	Free	Outfall	00
490.05	7.99	Free	Outfall	00
490.15	8.09	Free	Outfall	00
490.25	8.19	Free	Outfall	00
490.35	8.28	Free	Outfall	00
490.45	8.38	Free	Outfall	00
490.55	8.47	Free	Outfall	00
490.65	8.57	Free	Outfall	00
490.75	8.66	Free	Outfall	00
490.85	8.75	Free	Outfall	00
490.95	8.84	Free	Outfall	00
491.05	8.93	Free	Outfall	00
491.15	9.02	Free	Outfall	00
491.25	9.11	Free	Outfall	00
491.35	9.20	Free	Outfall	00
491.45	9.28	Free	Outfall	00
491.55	9.37	Free	Outfall	00
491.65	9.45	Free	Outfall	00
491.75	9.54	Free	Outfall	00
491.85	9.62	Free	Outfall	00
491.95	9.70	Free	Outfall	00
492.05	9.79	Free	Outfall	00
492.15	9.87	Free	Outfall	00
492.25	9.95	Free	Outfall	00
492.35	10.03	Free	Outfall	00
492.45	10.11	Free	Outfall	00
492.50	10.15	Free	Outfall	W1 +00
492.55	11.36	Free	Outfall	W1 +00
492.65	16.36	Free	Outfall	W1 +00
492.66	16.99	Free	Outfall	W1 +R0 +00
492.75	24.36	Free	Outfall	W1 +R0 +00
492.85	34.89	Free	Outfall	W1 +R0 +00

***** COMPOSITE OUTFLOW SUMMARY *****

WS Elev, Total Q		Converge		Notes
Elev. ft	Q cfs	TW Elev ft	Error +/-ft	Contributing Structures
492.95	47.34	Free	Outfall	W1 +R0 +O0
493.05	61.43	Free	Outfall	W1 +R0 +O0
493.15	76.98	Free	Outfall	W1 +R0 +O0
493.25	93.87	Free	Outfall	W1 +R0 +O0
493.35	111.98	Free	Outfall	W1 +R0 +O0
493.45	131.25	Free	Outfall	W1 +R0 +O0
493.55	151.61	Free	Outfall	W1 +R0 +O0
493.65	172.99	Free	Outfall	W1 +R0 +O0
493.75	195.37	Free	Outfall	W1 +R0 +O0
493.85	218.67	Free	Outfall	W1 +R0 +O0
493.95	242.89	Free	Outfall	W1 +R0 +O0
494.05	267.98	Free	Outfall	W1 +R0 +O0
494.15	290.44	Free	Outfall	W1 +R0 +O0
494.25	312.91	Free	Outfall	W1 +R0 +O0
494.35	335.91	Free	Outfall	W1 +R0 +O0
494.45	359.45	Free	Outfall	W1 +R0 +O0
494.55	383.50	Free	Outfall	W1 +R0 +O0
494.65	408.05	Free	Outfall	W1 +R0 +O0
494.75	433.10	Free	Outfall	W1 +R0 +O0
494.85	458.63	Free	Outfall	W1 +R0 +O0
494.95	484.65	Free	Outfall	W1 +R0 +O0
495.00	497.84	Free	Outfall	W1 +R0 +O0

LEVEL POOL ROUTING DATA

HYG Dir = H:\PONDPACK\9000PLUS\9203F-DATA\
 Inflow HYG file = NONE STORED - WEST IN 2
 Outflow HYG file = NONE STORED - WEST OUT 2

Pond Node Data = WEST
 Pond Volume Data = WEST
 Pond Outlet Data = WEST MODIFIED

No Infiltration

INITIAL CONDITIONS

 Starting WS Elev = 485.55 ft
 Starting Volume = 0 cu.ft
 Starting Outflow = .00 cfs
 Starting Infiltr. = .00 cfs
 Starting Total Qout= .00 cfs
 Time Increment = 1.00 min

Elevation ft	Outflow cfs	Storage cu.ft	Area sq.ft	Infilt. cfs	Q Total cfs	2S/t + O cfs
485.55	.00	0	0	.00	.00	.00
485.65	.08	2	51	.00	.08	.14
485.75	.22	14	204	.00	.22	.68
485.85	.41	46	459	.00	.41	1.94
485.95	.63	109	816	.00	.63	4.25
486.05	.88	212	1274	.00	.88	7.96
486.15	1.16	367	1835	.00	1.16	13.39
486.25	1.46	583	2498	.00	1.46	20.89
486.35	1.78	870	3262	.00	1.78	30.78
486.45	2.13	1239	4129	.00	2.13	43.41
486.55	2.82	1699	5097	.00	2.82	59.46
486.65	3.09	2261	6168	.00	3.09	78.48
486.75	3.34	2936	7340	.00	3.34	101.21
486.85	3.57	3733	8614	.00	3.57	128.00
486.95	3.79	4662	9990	.00	3.79	159.19
487.05	3.99	5734	11469	.00	3.99	195.14
487.15	4.19	6959	13049	.00	4.19	236.17
487.25	4.38	8348	14731	.00	4.38	282.63
487.35	4.55	9909	16515	.00	4.55	334.84
487.45	4.73	11654	18401	.00	4.73	393.18

Name.... WEST

File.... H:\PONDPACK\9000PLUS\9203F-DATA\AS-BUILT ULTIMATE PHASE.MODIFIED BASIN.04.17.2006

LEVEL POOL ROUTING DATA

HYG Dir = H:\PONDPACK\9000PLUS\9203F-DATA\
 Inflow HYG file = NONE STORED - WEST IN 2
 Outflow HYG file = NONE STORED - WEST OUT 2

Pond Node Data = WEST
 Pond Volume Data = WEST
 Pond Outlet Data = WEST MODIFIED

No Infiltration

INITIAL CONDITIONS

 Starting WS Elev = 485.55 ft
 Starting Volume = 0 cu.ft
 Starting Outflow = .00 cfs
 Starting Infiltr. = .00 cfs
 Starting Total Qout= .00 cfs
 Time Increment = 1.00 min

Elevation ft	Outflow cfs	Storage cu.ft	Area sq.ft	Infiltr. cfs	Q Total cfs	2S/t + O cfs
487.55	4.89	13592	20389	.00	4.89	457.97
487.65	5.05	15735	22479	.00	5.05	529.55
487.75	5.21	18092	24671	.00	5.21	608.27
487.85	5.36	20672	26964	.00	5.36	694.43
487.95	5.51	23488	29359	.00	5.51	788.42
488.05	5.65	26529	31111	.00	5.65	889.95
488.15	5.79	29692	32153	.00	5.79	995.53
488.25	5.93	32961	33213	.00	5.93	1104.61
488.35	6.06	36335	34289	.00	6.06	1217.22
488.45	6.19	39819	35383	.00	6.19	1333.47
488.55	6.32	43412	36494	.00	6.32	1453.40
488.65	6.44	47118	37623	.00	6.44	1577.05
488.75	6.56	50938	38768	.00	6.56	1704.49
488.85	6.68	54872	39930	.00	6.68	1835.74
488.95	6.80	58924	41110	.00	6.80	1970.93
489.05	6.92	63095	42307	.00	6.92	2110.08
489.15	7.03	67386	43521	.00	7.03	2253.24
489.25	7.15	71800	44753	.00	7.15	2400.48
489.35	7.26	76337	46001	.00	7.26	2551.81
489.45	7.37	81000	47267	.00	7.37	2707.37

Name.... WEST

File.... H:\PONDPACK\9000PLUS\9203F-DATA\AS-BUILT ULTIMATE PHASE.MODIFIED BASIN.04.17.2006

LEVEL POOL ROUTING DATA

HYG Dir = H:\PONDPACK\9000PLUS\9203F-DATA\
 Inflow HYG file = NONE STORED - WEST IN 2
 Outflow HYG file = NONE STORED - WEST OUT 2

Pond Node Data = WEST
 Pond Volume Data = WEST
 Pond Outlet Data = WEST MODIFIED

No Infiltration

INITIAL CONDITIONS

 Starting WS Elev = 485.55 ft
 Starting Volume = 0 cu.ft
 Starting Outflow = .00 cfs
 Starting Infiltr. = .00 cfs
 Starting Total Qout = .00 cfs
 Time Increment = 1.00 min

Elevation ft	Outflow cfs	Storage cu.ft	Area sq.ft	Infilt. cfs	Q Total cfs	2S/t + O cfs
489.55	7.47	85791	48550	.00	7.47	2867.18
489.65	7.58	90711	49850	.00	7.58	3031.28
489.75	7.68	95762	51167	.00	7.68	3199.76
489.85	7.79	100944	52501	.00	7.79	3372.59
489.95	7.89	106262	53853	.00	7.89	3549.95
490.05	7.99	111705	54790	.00	7.99	3731.49
490.15	8.09	117210	55301	.00	8.09	3915.09
490.25	8.19	122766	55815	.00	8.19	4100.39
490.35	8.28	128372	56331	.00	8.28	4287.35
490.45	8.38	134031	56849	.00	8.38	4476.09
490.55	8.47	139743	57370	.00	8.47	4666.56
490.65	8.57	145506	57893	.00	8.57	4858.77
490.75	8.66	151322	58419	.00	8.66	5052.72
490.85	8.75	157189	58947	.00	8.75	5248.38
490.95	8.84	163111	59477	.00	8.84	5445.85
491.05	8.93	169085	60010	.00	8.93	5645.10
491.15	9.02	175113	60545	.00	9.02	5846.12
491.25	9.11	181195	61082	.00	9.11	6048.93
491.35	9.20	187329	61622	.00	9.20	6253.48
491.45	9.28	193518	62164	.00	9.28	6459.89

Name.... WEST

File.... H:\PONDPACK\9000PLUS\9203F-DATA\AS-BUILT ULTIMATE PHASE.MODIFIED BASIN.04.17.2006

LEVEL POOL ROUTING DATA

HYG Dir = H:\PONDPACK\9000PLUS\9203F-DATA\
 Inflow HYG file = NONE STORED - WEST IN 2
 Outflow HYG file = NONE STORED - WEST OUT 2

Pond Node Data = WEST
 Pond Volume Data = WEST
 Pond Outlet Data = WEST MODIFIED

No Infiltration

INITIAL CONDITIONS

 Starting WS Elev = 485.55 ft
 Starting Volume = 0 cu.ft
 Starting Outflow = .00 cfs
 Starting Infiltr. = .00 cfs
 Starting Total Qout = .00 cfs
 Time Increment = 1.00 min

Elevation ft	Outflow cfs	Storage cu.ft	Area sq.ft	Infilt. cfs	Q Total cfs	2S/t + O cfs
491.55	9.37	199763	62709	.00	9.37	6668.10
491.65	9.45	206061	63256	.00	9.45	6878.14
491.75	9.54	212415	63805	.00	9.54	7090.01
491.85	9.62	218821	64357	.00	9.62	7303.64
491.95	9.70	225285	64911	.00	9.70	7519.18
492.05	9.79	231803	65412	.00	9.79	7736.53
492.15	9.87	238367	65860	.00	9.87	7955.41
492.25	9.95	244976	66310	.00	9.95	8175.79
492.35	10.03	251628	66761	.00	10.03	8397.60
492.45	10.11	258327	67214	.00	10.11	8620.98
492.50	10.15	261694	67441	.00	10.15	8733.27
492.55	11.36	265071	67668	.00	11.36	8847.05
492.65	16.36	271861	68124	.00	16.36	9078.38
492.66	16.99	272543	68169	.00	16.99	9101.75
492.75	24.36	278697	68581	.00	24.36	9314.23
492.85	34.89	285576	69039	.00	34.89	9554.07
492.95	47.34	292504	69500	.00	47.34	9797.44
493.05	61.43	299477	69962	.00	61.43	10043.98
493.15	76.98	306497	70425	.00	76.98	10293.52
493.25	93.87	313563	70890	.00	93.87	10545.94

Name.... WEST

File.... H:\PONDPACK\9000PLUS\9203F-DATA\AS-BUILT ULTIMATE PHASE.MODIFIED BASIN.04.17.2006

LEVEL POOL ROUTING DATA

HYG Dir = H:\PONDPACK\9000PLUS\9203F-DATA\
 Inflow HYG file = NONE STORED - WEST IN 2
 Outflow HYG file = NONE STORED - WEST OUT 2

Pond Node Data = WEST
 Pond Volume Data = WEST
 Pond Outlet Data = WEST MODIFIED

No Infiltration

INITIAL CONDITIONS

 Starting WS Elev = 485.55 ft
 Starting Volume = 0 cu.ft
 Starting Outflow = .00 cfs
 Starting Infiltr. = .00 cfs
 Starting Total Qout= .00 cfs
 Time Increment = 1.00 min

Elevation ft	Outflow cfs	Storage cu.ft	Area sq.ft	Infiltr. cfs	Q Total cfs	2S/t + O cfs
493.35	111.98	320673	71356	.00	111.98	10801.07
493.45	131.25	327833	71824	.00	131.25	11058.99
493.55	151.61	335039	72294	.00	151.61	11319.56
493.65	172.99	342293	72765	.00	172.99	11582.72
493.75	195.37	349593	73237	.00	195.37	11848.44
493.85	218.67	356939	73711	.00	218.67	12116.60
493.95	242.89	364334	74187	.00	242.89	12387.33
494.05	267.98	371776	74640	.00	267.98	12660.49
494.15	290.44	379262	75071	.00	290.44	12932.49
494.25	312.91	386791	75503	.00	312.91	13205.93
494.35	335.91	394362	75937	.00	335.91	13481.27
494.45	359.45	401977	76372	.00	359.45	13758.67
494.55	383.50	409637	76808	.00	383.50	14038.03
494.65	408.05	417340	77245	.00	408.05	14319.36
494.75	433.10	425087	77683	.00	433.10	14602.64
494.85	458.63	432875	78123	.00	458.63	14887.78
494.95	484.65	440710	78564	.00	484.65	15174.95
495.00	497.84	444645	78785	.00	497.84	15319.31

Name.... WEST

File.... H:\PONDPACK\9000PLUS\9203F-DATA\AS-BUILT ULTIMATE PHASE.MODIFIED BASIN.04.17.2006

SUMMARY FOR HYDROGRAPH ADDITION
 at Node: WEST IN

HYG Directory: H:\PONDPACK\9000PLUS\9203F-DATA\

Upstream Link ID	Upstream Node ID	HYG file	HYG ID	HYG tag
WEST	WEST		2 W	

INFLOWS TO: WEST IN

HYG file	HYG ID	HYG tag	Volume cu.ft	Peak Time min	Peak Flow cfs
	2 W		68218	8.00	56.85

TOTAL FLOW INTO: WEST IN

HYG file	HYG ID	HYG tag	Volume cu.ft	Peak Time min	Peak Flow cfs
	WEST	IN 2	68218	8.00	56.85

TOTAL NODE INFLOW...

HYG file =

HYG ID = WEST IN

HYG Tag = 2

```

-----
Peak Discharge =      56.85 cfs
Time to Peak   =      8.00 min
HYG Volume     =     68218 cu.ft
-----

```

HYDROGRAPH ORDINATES (cfs)

Output Time increment = 1.00 min

Time on left represents time for first value in each row.

Time min	Time on left represents time for first value in each row.				
.00	.00	7.11	14.21	21.32	28.42
5.00	35.53	42.64	49.74	56.85	56.85
10.00	56.85	56.85	56.85	56.85	56.85
15.00	56.85	56.85	56.85	56.85	56.85
20.00	56.85	49.74	42.64	35.53	28.42
25.00	21.32	14.21	7.11	.00	

SUMMARY FOR HYDROGRAPH ADDITION
at Node: WEST IN

HYG Directory: H:\PONDPACK\9000PLUS\9203F-DATA\

Upstream Link ID	Upstream Node ID	HYG file	HYG ID	HYG tag
WEST	WEST		15 W	

INFLOWS TO: WEST IN

HYG file	HYG ID	HYG tag	Volume cu.ft	Peak Time min	Peak Flow cfs
	15 W		110045	8.00	91.70

TOTAL FLOW INTO: WEST IN

HYG file	HYG ID	HYG tag	Volume cu.ft	Peak Time min	Peak Flow cfs
	WEST	IN 15	110045	8.00	91.70

TOTAL NODE INFLOW...

HYG file =

HYG ID = WEST IN

HYG Tag = 15

```

-----
Peak Discharge =          91.70 cfs
Time to Peak   =           8.00 min
HYG Volume     =         110045 cu.ft
-----

```

HYDROGRAPH ORDINATES (cfs)

Output Time increment = 1.00 min

Time on left represents time for first value in each row.

Time min	Output Time increment = 1.00 min				
	Time on left represents time for first value in each row.				
.00	.00	11.46	22.93	34.39	45.85
5.00	57.32	68.78	80.24	91.70	91.70
10.00	91.70	91.70	91.70	91.70	91.70
15.00	91.70	91.70	91.70	91.70	91.70
20.00	91.70	80.24	68.78	57.32	45.85
25.00	34.39	22.93	11.46	.00	

SUMMARY FOR HYDROGRAPH ADDITION
at Node: WEST IN

HYG Directory: H:\PONDPACK\9000PLUS\9203F-DATA\

```

=====
Upstream Link ID  Upstream Node ID  HYG file      HYG ID      HYG tag
-----
WEST              WEST              25 W
=====
    
```

```

INFLOWS TO: WEST      IN
-----
HYG file      HYG ID      HYG tag      Volume      Peak Time      Peak Flow
              HYG ID      HYG tag      cu.ft       min            cfs
-----
              25 W              136445      8.00        113.70
    
```

```

TOTAL FLOW INTO: WEST      IN
-----
HYG file      HYG ID      HYG tag      Volume      Peak Time      Peak Flow
              HYG ID      HYG tag      cu.ft       min            cfs
-----
WEST          IN  25          136445      8.00        113.70
    
```

TOTAL NODE INFLOW...

HYG file =
HYG ID = WEST IN
HYG Tag = 25

Peak Discharge = 113.70 cfs
Time to Peak = 8.00 min
HYG Volume = 136445 cu.ft

HYDROGRAPH ORDINATES (cfs)

Output Time increment = 1.00 min
Time on left represents time for first value in each row.

Time min					
.00	.00	14.21	28.43	42.64	56.85
5.00	71.07	85.28	99.49	113.70	113.70
10.00	113.70	113.70	113.70	113.70	113.70
15.00	113.70	113.70	113.70	113.70	113.70
20.00	113.70	99.49	85.28	71.07	56.85
25.00	42.64	28.43	14.21	.00	

LEVEL POOL ROUTING SUMMARY

HYG Dir = H:\PONDPACK\9000PLUS\9203F-DATA\
Inflow HYG file = NONE STORED - WEST IN 2
Outflow HYG file = NONE STORED - WEST OUT 2

Pond Node Data = WEST
Pond Volume Data = WEST
Pond Outlet Data = WEST MODIFIED

No Infiltration

INITIAL CONDITIONS

Starting WS Elev = 485.55 ft
Starting Volume = 0 cu.ft
Starting Outflow = .00 cfs
Starting Infiltr. = .00 cfs
Starting Total Qout= .00 cfs
Time Increment = 1.00 min

INFLOW/OUTFLOW HYDROGRAPH SUMMARY

Peak Inflow = 56.85 cfs at 8.00 min
Peak Outflow = 6.82 cfs at 27.00 min
Peak Elevation = 488.97 ft
Peak Storage = 59607 cu.ft

MASS BALANCE (cu.ft)

+ Initial Vol = 0
+ HYG Vol IN = 68218
- Infiltration = 0
- HYG Vol OUT = 68218
- Retained Vol = 0
Unrouted Vol = 0 cu.ft (.000% of Outflow Volume)

LEVEL POOL ROUTING SUMMARY

HYG Dir = H:\PONDPACK\9000PLUS\9203F-DATA\
 Inflow HYG file = NONE STORED - WEST IN 15
 Outflow HYG file = NONE STORED - WEST OUT 15

Pond Node Data = WEST
 Pond Volume Data = WEST
 Pond Outlet Data = WEST MODIFIED

No Infiltration

INITIAL CONDITIONS

 Starting WS Elev = 485.55 ft
 Starting Volume = 0 cu.ft
 Starting Outflow = .00 cfs
 Starting Infiltr. = .00 cfs
 Starting Total Qout= .00 cfs
 Time Increment = 1.00 min

INFLOW/OUTFLOW HYDROGRAPH SUMMARY

=====

Peak Inflow	=	91.70 cfs	at	8.00 min
Peak Outflow	=	7.77 cfs	at	27.00 min

Peak Elevation	=	489.84 ft
Peak Storage	=	100177 cu.ft

=====

MASS BALANCE (cu.ft)

+ Initial Vol	=	0	
+ HYG Vol IN	=	110045	
- Infiltration	=	0	
- HYG Vol OUT	=	110045	
- Retained Vol	=	0	

Unrouted Vol = - cu.ft (.000% of Inflow Volume)

LEVEL POOL ROUTING SUMMARY

HYG Dir = H:\PONDPACK\9000PLUS\9203F-DATA\
Inflow HYG file = NONE STORED - WEST IN 25
Outflow HYG file = NONE STORED - WEST OUT 25

Pond Node Data = WEST
Pond Volume Data = WEST
Pond Outlet Data = WEST MODIFIED

No Infiltration

INITIAL CONDITIONS

Starting WS Elev = 485.55 ft
Starting Volume = 0 cu.ft
Starting Outflow = .00 cfs
Starting Infiltr. = .00 cfs
Starting Total Qout= .00 cfs
Time Increment = 1.00 min

INFLOW/OUTFLOW HYDROGRAPH SUMMARY

=====
Peak Inflow = 113.70 cfs at 8.00 min
Peak Outflow = 8.24 cfs at 27.00 min

Peak Elevation = 490.31 ft
Peak Storage = 125927 cu.ft
=====

MASS BALANCE (cu.ft)

+ Initial Vol = 0
+ HYG Vol IN = 136445
- Infiltration = 0
- HYG Vol OUT = 136445
- Retained Vol = 0

Unrouted Vol = 0 cu.ft (.000% of Outflow Volume)

----- W -----
WEST... 4.01, 6.01
WEST IN 2... 6.06, 6.08,
 6.10
WEST OUT 2... 2.01, 3.01,
 6.12, 2.03, 3.03, 6.13, 2.05,
 3.05, 6.14
WEST MODIFIED... 5.01, 5.04

STORMWATER DETENTION CALCULATIONS

ULTIMATE DEVELOPMENT

EAST BASIN

Table of Contents

***** NETWORK SUMMARIES (DETAILED) *****

Watershed..... 2
 Executive Summary (Nodes) 1.01

Watershed..... 15
 Executive Summary (Nodes) 1.02

Watershed..... 25
 Executive Summary (Nodes) 1.03

***** TIME VS.ELEV *****

EAST OUT 2
 Time-Elev 2.01

EAST OUT 15
 Time-Elev 2.02

EAST OUT 25
 Time-Elev 2.03

***** TIME VS.VOL *****

EAST OUT 2
 Time vs. Volume 3.01

EAST OUT 15
 Time vs. Volume 3.02

EAST OUT 25
 Time vs. Volume 3.03

***** POND VOLUMES *****

EAST..... Vol: Planimeter 4.01

Table of Contents

***** OUTLET STRUCTURES *****

EAST MODIFIED...	Outlet Input Data	5.01
	Composite Rating Curve	5.04

***** POND ROUTING *****

EAST.....	Pond E-V-Q Table	6.01
EAST	IN 2	
	Node: Pond Inflow Summary	6.05
EAST	IN 15	
	Node: Pond Inflow Summary	6.07
EAST	IN 25	
	Node: Pond Inflow Summary	6.09
EAST	OUT 2	
	Pond Routing Summary	6.11
EAST	OUT 15	
	Pond Routing Summary	6.12
EAST	OUT 25	
	Pond Routing Summary	6.13

Table of Contents (continued)

NETWORK SUMMARY -- NODES

(Trun.= HYG Truncation: Blank=None; L=Left; R=Rt; LR=Left & Rt)

Node ID	Type	HYG Vol cu.ft	Trun.	Qpeak min	Qpeak cfs	Max WSEL ft
EAST	HYG	63605		12.00	53.00	
Outfall EAST	JCT	63605		22.00	42.47	
EAST	IN POND	63605		12.00	53.00	
EAST	OUT POND	63605		22.00	42.47	481.52
WEST	HYG	68218		8.00	56.85	
Outfall WEST	JCT	68218		27.00	6.82	
WEST	IN POND	68218		8.00	56.85	
WEST	OUT POND	68218		27.00	6.82	488.97

NETWORK SUMMARY -- NODES

(Trun.= HYG Truncation: Blank=None; L=Left; R=Rt; LR=Left & Rt)

Node ID	Type	HYG Vol cu.ft	Trun.	Qpeak min	Qpeak cfs	Max WSEL ft
EAST	HYG	102600		12.00	85.50	
Outfall EAST	JCT	102600		22.00	73.17	
EAST	IN POND	102600		12.00	85.50	
EAST	OUT POND	102600		22.00	73.17	482.84
WEST	HYG	110045		8.00	91.70	
Outfall WEST	JCT	110045		27.00	7.77	
WEST	IN POND	110045		8.00	91.70	
WEST	OUT POND	110045		27.00	7.77	489.84

NETWORK SUMMARY -- NODES

(Trun.= HYG Truncation: Blank=None; L=Left; R=Rt; LR=Left & Rt)

Node ID	Type	HYG Vol cu.ft	Trun.	Qpeak min	Qpeak cfs	Max WSEL ft
EAST	HYG	126836		12.00	105.70	
Outfall EAST	JCT	126836		21.00	96.63	
EAST	IN POND	126836		12.00	105.70	
EAST	OUT POND	126836		21.00	96.63	483.18
WEST	HYG	136445		8.00	113.70	
Outfall WEST	JCT	136445		27.00	8.24	
WEST	IN POND	136445		8.00	113.70	
WEST	OUT POND	136445		27.00	8.24	490.31

TIME vs. ELEVATION (ft)

Time min	Output Time increment = 1.00 min				
	Time on left represents time for first value in each row.				

.00	477.19	477.75	478.13	478.44	478.74
5.00	479.01	479.26	479.50	479.73	479.95
10.00	480.15	480.33	480.52	480.69	480.84
15.00	480.97	481.08	481.18	481.27	481.36
20.00	481.43	481.49	481.52	481.51	481.48
25.00	481.42	481.34	481.22	481.08	480.89
30.00	480.67	480.39	480.08	479.75	479.40
35.00	479.04	478.68	478.29	477.90	477.33
40.00	477.19				

TIME vs. ELEVATION (ft)

Time min	Output Time increment = 1.00 min				
	Time on left represents time for first value in each row.				
.00	477.19	477.91	478.36	478.77	479.14
5.00	479.49	479.81	480.10	480.38	480.65
10.00	480.92	481.20	481.48	481.74	481.96
15.00	482.17	482.35	482.50	482.62	482.71
20.00	482.78	482.83	482.84	482.82	482.77
25.00	482.71	482.64	482.55	482.44	482.32
30.00	482.17	481.99	481.76	481.49	481.21
35.00	480.91	480.59	480.24	479.89	479.55
40.00	479.20	478.83	478.45	478.07	477.58
45.00	477.19				

TIME vs. ELEVATION (ft)

Time min	Output Time increment = 1.00 min				
	Time on left represents time for first value in each row.				

.00	477.19	477.98	478.49	478.94	479.35
5.00	479.73	480.08	480.40	480.71	481.03
10.00	481.35	481.67	481.99	482.28	482.53
15.00	482.72	482.86	482.97	483.05	483.12
20.00	483.16	483.18	483.17	483.13	483.07
25.00	482.99	482.90	482.80	482.68	482.55
30.00	482.40	482.23	482.01	481.76	481.50
35.00	481.22	480.92	480.60	480.25	479.90
40.00	479.56	479.21	478.84	478.46	478.08
45.00	477.60	477.19			

TIME vs. VOLUME (cu.ft)

Time min	Output Time increment = 1.00 min				
	Time on left represents time for first value in each row.				
.00	0	54	252	549	952
5.00	1457	2059	2760	3555	4448
10.00	5377	6321	7374	8460	9454
15.00	10381	11247	12059	12824	13547
20.00	14234	14762	14999	14969	14684
25.00	14149	13385	12403	11220	9853
30.00	8322	6666	5035	3616	2456
35.00	1539	857	390	112	1
40.00	0				

TIME vs. VOLUME (cu.ft)

Time min	Output Time increment = 1.00 min				
	Time on left represents time for first value in each row.				
.00	0	116	460	1014	1765
5.00	2713	3849	5161	6582	8169
10.00	10038	12197	14647	17185	19621
15.00	21967	24181	26149	27781	29100
20.00	30150	30778	30891	30599	29991
25.00	29129	28061	26818	25412	23833
30.00	22010	19864	17371	14779	12304
35.00	9971	7800	5811	4175	2906
40.00	1892	1112	558	206	19
45.00	0				

TIME vs. VOLUME (cu.ft)

Time min	Output Time increment = 1.00 min				
	Time on left represents time for first value in each row.				
.00	0	153	602	1322	2306
5.00	3547	5045	6714	8606	10859
10.00	13484	16490	19886	23400	26580
15.00	29221	31321	32957	34215	35178
20.00	35910	36237	36016	35383	34440
25.00	33256	31875	30338	28662	26846
30.00	24884	22700	20155	17444	14847
35.00	12369	10033	7857	5863	4219
40.00	2943	1919	1133	573	215
45.00	21	0			

POND VOLUME CALCULATIONS

Planimeter scale: 1.00 ft/in

Elevation (ft)	Planimeter (sq.in)	Area (sq.ft)	$A1+A2+\text{sqr}(A1*A2)$ (sq.ft)	Volume (cu.ft)	Volume Sum (cu.ft)
477.19	.000	0	0	0	0
478.00	605.000	605	605	163	163
480.00	4509.000	4509	6766	4510	4674
482.00	11365.000	11365	23033	15355	20029
484.00	20067.000	20067	46534	31022	51051

POND VOLUME EQUATIONS

* Incremental volume computed by the Conic Method for Reservoir Volumes.

$$\text{Volume} = (1/3) * (\text{EL2}-\text{EL1}) * (\text{Area1} + \text{Area2} + \text{sq.rt.}(\text{Area1}*\text{Area2}))$$

where: EL1, EL2 = Lower and upper elevations of the increment
Area1,Area2 = Areas computed for EL1, EL2, respectively
Volume = Incremental volume between EL1 and EL2

REQUESTED POND WS ELEVATIONS:

Min. Elev.= 477.19 ft
Increment = .10 ft
Max. Elev.= 484.00 ft

OUTLET CONNECTIVITY

---> Forward Flow Only (UpStream to DnStream)
<--- Reverse Flow Only (DnStream to UpStream)
<---> Forward and Reverse Both Allowed

Structure	No.		Outfall	E1, ft	E2, ft
Weir-Rectangular	W0	--->	TW	477.190	480.190
Stand Pipe	R0	--->	TW	482.240	484.000
Orifice-Area	O0	--->	TW	480.190	484.000
TW SETUP, DS Channel					

Name.... EAST MODIFIED

File.... H:\PONDPACK\9000PLUS\9203F-DATA\AS-BUILT ULTIMATE PHASE.MODIFIED BASIN.04.17.2006

OUTLET STRUCTURE INPUT DATA

Structure ID = W0
Structure Type = Weir-Rectangular

of Openings = 1
Crest Elev. = 477.19 ft
Weir Length = 1.75 ft
Weir Coeff. = 3.000000

Weir TW effects (Use adjustment equation)

Structure ID = R0
Structure Type = Stand Pipe

of Openings = 1
Invert Elev. = 482.24 ft
Diameter = 5.0000 ft
Orifice Area = 19.6350 sq.ft
Orifice Coeff. = .600
Weir Length = 15.71 ft
Weir Coeff. = 3.000
K, Reverse = 1.000
Mannings n = .0000
Kev,Charged Riser = .000
Weir Submergence = No
Orifice H to crest= Yes

OUTLET STRUCTURE INPUT DATA

Structure ID = 00
 Structure Type = Orifice-Area

 # of Openings = 1
 Invert Elev. = 477.19 ft
 Area = 5.2500 sq.ft
 Top of Orifice = 480.19 ft
 Datum Elev. = 478.69 ft
 Orifice Coeff. = .600

Structure ID = TW
 Structure Type = TW SETUP, DS Channel

FREE OUTFALL CONDITIONS SPECIFIED

CONVERGENCE TOLERANCES...
 Maximum Iterations= 40
 Min. TW tolerance = .01 ft
 Max. TW tolerance = .01 ft
 Min. HW tolerance = .01 ft
 Max. HW tolerance = .01 ft
 Min. Q tolerance = .00 cfs
 Max. Q tolerance = .00 cfs

Name.... EAST MODIFIED

File.... H:\PONDPACK\9000PLUS\9203F-DATA\AS-BUILT ULTIMATE PHASE.MODIFIED BASIN.04.17.2006

***** COMPOSITE OUTFLOW SUMMARY *****

WS Elev, Total Q		Converge		Notes
Elev. ft	Q cfs	TW Elev ft	Error +/-ft	Contributing Structures
477.19	.00	Free Outfall	WO	
477.29	.17	Free Outfall	WO	
477.39	.47	Free Outfall	WO	
477.49	.86	Free Outfall	WO	
477.59	1.33	Free Outfall	WO	
477.69	1.86	Free Outfall	WO	
477.79	2.44	Free Outfall	WO	
477.89	3.07	Free Outfall	WO	
477.99	3.76	Free Outfall	WO	
478.09	4.48	Free Outfall	WO	
478.19	5.25	Free Outfall	WO	
478.29	6.06	Free Outfall	WO	
478.39	6.90	Free Outfall	WO	
478.49	7.78	Free Outfall	WO	
478.59	8.70	Free Outfall	WO	
478.69	9.64	Free Outfall	WO	
478.79	10.63	Free Outfall	WO	
478.89	11.64	Free Outfall	WO	
478.99	12.68	Free Outfall	WO	
479.09	13.75	Free Outfall	WO	
479.19	14.85	Free Outfall	WO	
479.29	15.98	Free Outfall	WO	
479.39	17.13	Free Outfall	WO	
479.49	18.31	Free Outfall	WO	
479.59	19.52	Free Outfall	WO	
479.69	20.75	Free Outfall	WO	
479.79	22.01	Free Outfall	WO	
479.89	23.29	Free Outfall	WO	
479.99	24.60	Free Outfall	WO	
480.09	25.93	Free Outfall	WO	
480.19	30.95	Free Outfall	OO	
480.29	31.96	Free Outfall	OO	
480.39	32.95	Free Outfall	OO	
480.49	33.90	Free Outfall	OO	
480.59	34.83	Free Outfall	OO	
480.69	35.73	Free Outfall	OO	
480.79	36.62	Free Outfall	OO	
480.89	37.48	Free Outfall	OO	

***** COMPOSITE OUTFLOW SUMMARY *****

WS Elev, Total Q		Converge		Notes
Elev. ft	Q cfs	TW Elev ft	Error +/-ft	Contributing Structures
480.99	38.32	Free	Outfall	00
481.09	39.15	Free	Outfall	00
481.19	39.95	Free	Outfall	00
481.29	40.74	Free	Outfall	00
481.39	41.52	Free	Outfall	00
481.49	42.28	Free	Outfall	00
481.59	43.03	Free	Outfall	00
481.69	43.77	Free	Outfall	00
481.79	44.49	Free	Outfall	00
481.89	45.20	Free	Outfall	00
481.99	45.90	Free	Outfall	00
482.09	46.59	Free	Outfall	00
482.19	47.27	Free	Outfall	00
482.24	47.61	Free	Outfall	R0 +00
482.29	48.47	Free	Outfall	R0 +00
482.39	51.34	Free	Outfall	R0 +00
482.49	55.15	Free	Outfall	R0 +00
482.59	59.66	Free	Outfall	R0 +00
482.69	64.76	Free	Outfall	R0 +00
482.79	70.39	Free	Outfall	R0 +00
482.89	76.48	Free	Outfall	R0 +00
482.99	83.01	Free	Outfall	R0 +00
483.09	89.93	Free	Outfall	R0 +00
483.19	97.24	Free	Outfall	R0 +00
483.29	104.90	Free	Outfall	R0 +00
483.39	112.90	Free	Outfall	R0 +00
483.49	121.22	Free	Outfall	R0 +00
483.59	129.85	Free	Outfall	R0 +00
483.69	138.78	Free	Outfall	R0 +00
483.79	148.00	Free	Outfall	R0 +00
483.89	157.50	Free	Outfall	R0 +00
483.99	167.27	Free	Outfall	R0 +00
484.00	168.26	Free	Outfall	R0 +00

Name.... EAST MODIFIED

LEVEL POOL ROUTING DATA

HYG Dir = H:\PONDPACK\9000PLUS\9203F-DATA\
 Inflow HYG file = NONE STORED - EAST IN 2
 Outflow HYG file = NONE STORED - EAST OUT 2

Pond Node Data = EAST
 Pond Volume Data = EAST
 Pond Outlet Data = EAST MODIFIED

No Infiltration

INITIAL CONDITIONS

 Starting WS Elev = 477.19 ft
 Starting Volume = 0 cu.ft
 Starting Outflow = .00 cfs
 Starting Infiltr. = .00 cfs
 Starting Total Qout= .00 cfs
 Time Increment = 1.00 min

Elevation ft	Outflow cfs	Storage cu.ft	Area sq.ft	Infiltr. cfs	Q Total cfs	2S/t + O cfs
477.19	.00	0	0	.00	.00	.00
477.29	.17	0	9	.00	.17	.18
477.39	.47	2	37	.00	.47	.55
477.49	.86	8	83	.00	.86	1.14
477.59	1.33	20	148	.00	1.33	1.98
477.69	1.86	38	231	.00	1.86	3.14
477.79	2.44	66	332	.00	2.44	4.65
477.89	3.07	105	452	.00	3.07	6.59
477.99	3.76	157	590	.00	3.76	9.00
478.09	4.48	222	703	.00	4.48	11.89
478.19	5.25	298	820	.00	5.25	15.19
478.29	6.06	386	947	.00	6.06	18.94
478.39	6.90	488	1082	.00	6.90	23.16
478.49	7.78	603	1227	.00	7.78	27.89
478.59	8.70	733	1380	.00	8.70	33.14
478.69	9.64	880	1543	.00	9.64	38.96
478.79	10.63	1042	1714	.00	10.63	45.37
478.89	11.64	1223	1895	.00	11.64	52.39
478.99	12.68	1422	2085	.00	12.68	60.06
479.09	13.75	1640	2284	.00	13.75	68.41

Name.... EAST

File.... H:\PONDPACK\9000PLUS\9203F-DATA\AS-BUILT ULTIMATE PHASE.MODIFIED BASIN.04.17.2006

LEVEL POOL ROUTING DATA

HYG Dir = H:\PONDPACK\9000PLUS\9203F-DATA\
 Inflow HYG file = NONE STORED - EAST IN 2
 Outflow HYG file = NONE STORED - EAST OUT 2

Pond Node Data = EAST
 Pond Volume Data = EAST
 Pond Outlet Data = EAST MODIFIED

No Infiltration

INITIAL CONDITIONS

 Starting WS Elev = 477.19 ft
 Starting Volume = 0 cu.ft
 Starting Outflow = .00 cfs
 Starting Infiltr. = .00 cfs
 Starting Total Qout= .00 cfs
 Time Increment = 1.00 min

Elevation ft	Outflow cfs	Storage cu.ft	Area sq.ft	Infiltr. cfs	Q Total cfs	2S/t + O cfs
479.19	14.85	1879	2492	.00	14.85	77.47
479.29	15.98	2139	2708	.00	15.98	87.26
479.39	17.13	2421	2934	.00	17.13	97.82
479.49	18.31	2726	3169	.00	18.31	109.17
479.59	19.52	3055	3414	.00	19.52	121.35
479.69	20.75	3409	3667	.00	20.75	134.38
479.79	22.01	3789	3929	.00	22.01	148.29
479.89	23.29	4195	4200	.00	23.29	163.12
479.99	24.60	4629	4480	.00	24.60	178.89
480.09	25.93	5090	4751	.00	25.93	195.61
480.19	30.95	5579	5026	.00	30.95	216.92
480.29	31.96	6096	5310	.00	31.96	235.16
480.39	32.95	6642	5602	.00	32.95	254.33
480.49	33.90	7216	5901	.00	33.90	274.45
480.59	34.83	7822	6208	.00	34.83	295.56
480.69	35.73	8458	6523	.00	35.73	317.68
480.79	36.62	9127	6845	.00	36.62	340.84
480.89	37.48	9828	7175	.00	37.48	365.07
480.99	38.32	10562	7513	.00	38.32	390.38
481.09	39.15	11331	7859	.00	39.15	416.83

Name.... EAST

File.... H:\PONDPACK\9000PLUS\9203F-DATA\AS-BUILT ULTIMATE PHASE.MODIFIED BASIN.04.17.2006

LEVEL POOL ROUTING DATA

HYG Dir = H:\PONDPACK\9000PLUS\9203F-DATA\
Inflow HYG file = NONE STORED - EAST IN 2
Outflow HYG file = NONE STORED - EAST OUT 2

Pond Node Data = EAST
Pond Volume Data = EAST
Pond Outlet Data = EAST MODIFIED

No Infiltration

INITIAL CONDITIONS

Starting WS Elev = 477.19 ft
Starting Volume = 0 cu.ft
Starting Outflow = .00 cfs
Starting Infiltr. = .00 cfs
Starting Total Qout = .00 cfs
Time Increment = 1.00 min

Table with 7 columns: Elevation ft, Outflow cfs, Storage cu.ft, Area sq.ft, Infiltr. cfs, Q Total cfs, 2S/t + O cfs. It contains 20 rows of data showing the relationship between elevation and various flow and storage parameters.

Name.... EAST

File.... H:\PONDPACK\9000PLUS\9203F-DATA\AS-BUILT ULTIMATE PHASE.MODIFIED BASIN.04.17.2006

LEVEL POOL ROUTING DATA

HYG Dir = H:\PONDPACK\9000PLUS\9203F-DATA\
 Inflow HYG file = NONE STORED - EAST IN 2
 Outflow HYG file = NONE STORED - EAST OUT 2

Pond Node Data = EAST
 Pond Volume Data = EAST
 Pond Outlet Data = EAST MODIFIED

No Infiltration

INITIAL CONDITIONS

 Starting WS Elev = 477.19 ft
 Starting Volume = 0 cu.ft
 Starting Outflow = .00 cfs
 Starting Infiltr. = .00 cfs
 Starting Total Qout= .00 cfs
 Time Increment = 1.00 min

Elevation ft	Outflow cfs	Storage cu.ft	Area sq.ft	Infilt. cfs	Q Total cfs	2S/t + O cfs
483.09	89.93	34769	15803	.00	89.93	1248.90
483.19	97.24	36372	16247	.00	97.24	1309.62
483.29	104.90	38019	16697	.00	104.90	1372.19
483.39	112.90	39711	17153	.00	112.90	1436.60
483.49	121.22	41449	17615	.00	121.22	1502.85
483.59	129.85	43234	18083	.00	129.85	1570.98
483.69	138.78	45066	18557	.00	138.78	1640.98
483.79	148.00	46946	19038	.00	148.00	1712.86
483.89	157.50	48874	19525	.00	157.50	1786.63
483.99	167.27	50851	20017	.00	167.27	1862.28
484.00	168.26	51051	20067	.00	168.26	1869.96

Name.... EAST

File.... H:\PONDPACK\9000PLUS\9203F-DATA\AS-BUILT ULTIMATE PHASE.MODIFIED BASIN.04.17.2006

SUMMARY FOR HYDROGRAPH ADDITION
at Node: EAST IN

HYG Directory: H:\PONDPACK\9000PLUS\9203F-DATA\

```

=====
Upstream Link ID  Upstream Node ID  HYG file      HYG ID        HYG tag
-----
EAST              EAST                2 E
=====

```

```

INFLOWS TO:  EAST          IN
-----
HYG file      HYG ID          HYG tag        Volume      Peak Time    Peak Flow
              HYG ID          HYG tag        cu.ft       min          cfs
-----
              2 E              63605          12.00       53.00

```

```

TOTAL FLOW INTO:  EAST          IN
-----
HYG file      HYG ID          HYG tag        Volume      Peak Time    Peak Flow
              HYG ID          HYG tag        cu.ft       min          cfs
-----
              EAST          IN  2              63605          12.00       53.00

```

TOTAL NODE INFLOW...

HYG file =

HYG ID = EAST IN

HYG Tag = 2

 Peak Discharge = 53.00 cfs
 Time to Peak = 12.00 min
 HYG Volume = 63605 cu.ft

HYDROGRAPH ORDINATES (cfs)

Output Time increment = 1.00 min

Time on left represents time for first value in each row.

Time min					
.00	.00	4.42	8.83	13.25	17.67
5.00	22.09	26.50	30.92	35.34	39.75
10.00	44.17	48.59	53.00	53.00	53.00
15.00	53.00	53.00	53.00	53.00	53.00
20.00	53.00	48.59	44.17	39.75	35.34
25.00	30.92	26.50	22.09	17.67	13.25
30.00	8.83	4.42	.00		

SUMMARY FOR HYDROGRAPH ADDITION
at Node: EAST IN

HYG Directory: H:\PONDPACK\9000PLUS\9203F-DATA\

```

=====
Upstream Link ID  Upstream Node ID  HYG file      HYG ID      HYG tag
-----
EAST              EAST                  15 E
=====

```

```

INFLOWS TO:  EAST          IN
-----
HYG file      HYG ID          HYG tag      Volume      Peak Time     Peak Flow
              HYG ID          HYG tag      cu.ft       min           cfs
-----
              15 E           102600      12.00      85.50

```

```

TOTAL FLOW INTO:  EAST          IN
-----
HYG file      HYG ID          HYG tag      Volume      Peak Time     Peak Flow
              HYG ID          HYG tag      cu.ft       min           cfs
-----
              EAST          IN  15      102600      12.00      85.50

```

TOTAL NODE INFLOW...

HYG file =

HYG ID = EAST IN

HYG Tag = 15

Peak Discharge = 85.50 cfs

Time to Peak = 12.00 min

HYG Volume = 102600 cu.ft

HYDROGRAPH ORDINATES (cfs)

Output Time increment = 1.00 min

Time |
min | Time on left represents time for first value in each row.

Time min	0.00	5.00	10.00	15.00	20.00	25.00	30.00
0.00	.00	7.13	14.25	21.38	28.50		
5.00	35.63	42.75	49.88	57.00	64.13		
10.00	71.25	78.38	85.50	85.50	85.50		
15.00	85.50	85.50	85.50	85.50	85.50		
20.00	85.50	78.38	71.25	64.13	57.00		
25.00	49.88	42.75	35.63	28.50	21.38		
30.00	14.25	7.13	.00				

SUMMARY FOR HYDROGRAPH ADDITION
at Node: EAST IN

HYG Directory: H:\PONDPACK\9000PLUS\9203F-DATA\

```

=====
Upstream Link ID  Upstream Node ID  HYG file      HYG ID      HYG tag
-----
EAST              EAST                25 E
=====

```

```

INFLOWS TO:  EAST          IN
-----
HYG file      HYG ID          HYG tag      Volume      Peak Time     Peak Flow
              HYG ID          HYG tag      cu.ft       min           cfs
-----
              25 E           126836      12.00       105.70

```

```

TOTAL FLOW INTO:  EAST          IN
-----
HYG file      HYG ID          HYG tag      Volume      Peak Time     Peak Flow
              HYG ID          HYG tag      cu.ft       min           cfs
-----
              EAST          IN  25          126836      12.00       105.70

```

TOTAL NODE INFLOW...

HYG file =

HYG ID = EAST IN

HYG Tag = 25

 Peak Discharge = 105.70 cfs
 Time to Peak = 12.00 min
 HYG Volume = 126836 cu.ft

HYDROGRAPH ORDINATES (cfs)

Output Time increment = 1.00 min

Time |
 min | Time on left represents time for first value in each row.

Time min	8.81	17.62	26.42	35.23
.00	8.81	17.62	26.42	35.23
5.00	44.04	52.85	61.66	70.46
10.00	88.08	96.89	105.70	105.70
15.00	105.70	105.70	105.70	105.70
20.00	105.70	96.89	88.08	79.27
25.00	61.66	52.85	44.04	35.23
30.00	17.62	8.81	.00	

LEVEL POOL ROUTING SUMMARY

HYG Dir = H:\PONDPACK\9000PLUS\9203F-DATA\
Inflow HYG file = NONE STORED - EAST IN 2
Outflow HYG file = NONE STORED - EAST OUT 2

Pond Node Data = EAST
Pond Volume Data = EAST
Pond Outlet Data = EAST MODIFIED

No Infiltration

INITIAL CONDITIONS

Starting WS Elev = 477.19 ft
Starting Volume = 0 cu.ft
Starting Outflow = .00 cfs
Starting Infiltr. = .00 cfs
Starting Total Qout = .00 cfs
Time Increment = 1.00 min

INFLOW/OUTFLOW HYDROGRAPH SUMMARY

=====
Peak Inflow = 53.00 cfs at 12.00 min
Peak Outflow = 42.47 cfs at 22.00 min

Peak Elevation = 481.52 ft
Peak Storage = 14999 cu.ft
=====

MASS BALANCE (cu.ft)

+ Initial Vol = 0
+ HYG Vol IN = 63605
- Infiltration = 0
- HYG Vol OUT = 63605
- Retained Vol = 0

Unrouted Vol = 0 cu.ft (.000% of Outflow Volume)

LEVEL POOL ROUTING SUMMARY

HYG Dir = H:\PONDPACK\9000PLUS\9203F-DATA\
 Inflow HYG file = NONE STORED - EAST IN 15
 Outflow HYG file = NONE STORED - EAST OUT 15

Pond Node Data = EAST
 Pond Volume Data = EAST
 Pond Outlet Data = EAST MODIFIED

No Infiltration

INITIAL CONDITIONS

 Starting WS Elev = 477.19 ft
 Starting Volume = 0 cu.ft
 Starting Outflow = .00 cfs
 Starting Infiltr. = .00 cfs
 Starting Total Qout= .00 cfs
 Time Increment = 1.00 min

INFLOW/OUTFLOW HYDROGRAPH SUMMARY

=====
 Peak Inflow = 85.50 cfs at 12.00 min
 Peak Outflow = 73.17 cfs at 22.00 min

 Peak Elevation = 482.84 ft
 Peak Storage = 30891 cu.ft
 =====

MASS BALANCE (cu.ft)

 + Initial Vol = 0
 + HYG Vol IN = 102600
 - Infiltration = 0
 - HYG Vol OUT = 102600
 - Retained Vol = 0

 Unrouted Vol = 0 cu.ft (.000% of Outflow Volume)

LEVEL POOL ROUTING SUMMARY

HYG Dir = H:\PONDPACK\9000PLUS\9203F-DATA\
Inflow HYG file = NONE STORED - EAST IN 25
Outflow HYG file = NONE STORED - EAST OUT 25

Pond Node Data = EAST
Pond Volume Data = EAST
Pond Outlet Data = EAST MODIFIED

No Infiltration

INITIAL CONDITIONS

Starting WS Elev = 477.19 ft
Starting Volume = 0 cu.ft
Starting Outflow = .00 cfs
Starting Infiltr. = .00 cfs
Starting Total Qout = .00 cfs
Time Increment = 1.00 min

INFLOW/OUTFLOW HYDROGRAPH SUMMARY

=====
Peak Inflow = 105.70 cfs at 12.00 min
Peak Outflow = 96.63 cfs at 21.00 min

Peak Elevation = 483.18 ft
Peak Storage = 36237 cu.ft
=====

MASS BALANCE (cu.ft)

+ Initial Vol = 0
+ HYG Vol IN = 126836
- Infiltration = 0
- HYG Vol OUT = 126836
- Retained Vol = 0

Unrouted Vol = 0 cu.ft (.000% of Outflow Volume)

----- E -----

EAST... 4.01, 6.01

EAST IN 2... 6.05, 6.07,
6.09

EAST OUT 2... 2.01, 3.01,
6.11, 2.02, 3.02, 6.12, 2.03,
3.03, 6.13

EAST MODIFIED... 5.01, 5.04, 1.01,
1.02, 1.03

STORMWATER DETENTION CALCULATIONS

ULTIMATE DEVELOPMENT

WEST BASIN

100 YR. LOW FLOW BLOCKED

Table of Contents

***** NETWORK SUMMARIES (DETAILED) *****

Watershed..... 100
Executive Summary (Nodes) 1.01

***** TIME VS.ELEV *****

WEST OUT 100
Time-Elev 2.01

***** TIME VS.VOL *****

WEST OUT 100
Time vs. Volume 3.01

***** POND VOLUMES *****

WEST..... Vol: Planimeter 4.01

***** OUTLET STRUCTURES *****

WEST MOD. LFB... Outlet Input Data 5.01
Composite Rating Curve 5.03

***** POND ROUTING *****

WEST..... Pond E-V-Q Table 6.01

Table of Contents

WEST	IN 100	
	Node: Pond Inflow Summary	6.06
WEST	OUT 100	
	Pond Routing Summary	6.08

Table of Contents (continued)

NETWORK SUMMARY -- NODES
 (Trun.= HYG Truncation: Blank=None; L=Left; R=Rt; LR=Left & Rt)

Node ID	Type	HYG Vol cu.ft	Trun.	Qpeak min	Qpeak cfs	Max WSEL ft
EAST	HYG	162000		12.00	135.00	
Outfall EAST	JCT	161997		20.00	130.16	
EAST	IN POND	162000		12.00	135.00	
EAST	OUT POND	161997		20.00	130.16	484.22
WEST	HYG	173760		8.00	144.80	
Outfall WEST	JCT	184601	L	21.00	130.66	
WEST	IN POND	173760		8.00	144.80	
WEST	OUT POND	184601	L	21.00	130.66	493.50

TIME vs. ELEVATION (ft)

Output Time increment = 1.00 min
 Time on left represents time for first value in each row.

Time min					
.00	492.66	492.66	492.68	492.71	492.75
5.00	492.81	492.88	492.95	493.03	493.11
10.00	493.18	493.23	493.29	493.33	493.37
15.00	493.40	493.42	493.45	493.47	493.48
20.00	493.50	493.50	493.49	493.47	493.44
25.00	493.39	493.34	493.29	493.22	493.16
30.00	493.11	493.06	493.02	492.98	492.95
35.00	492.92	492.89	492.86	492.84	492.82
40.00	492.81	492.79	492.77	492.76	492.75
45.00	492.74	492.72	492.71	492.71	492.70
50.00	492.69	492.68	492.67	492.67	492.66
55.00	492.65	492.65	492.64	492.64	492.63
60.00	492.63	492.63	492.62	492.62	492.61
65.00	492.61	492.61	492.60	492.60	492.60
70.00	492.59	492.59	492.59	492.58	492.58
75.00	492.58	492.58	492.58	492.57	492.57
80.00	492.57	492.57	492.57	492.56	492.56
85.00	492.56	492.56	492.56	492.56	492.56
90.00	492.55	492.55	492.55	492.55	492.55
95.00	492.55	492.55	492.55	492.55	492.54
100.00	492.54	492.54	492.54	492.54	492.54
105.00	492.54	492.54	492.54	492.54	492.54
110.00	492.54	492.53	492.53	492.53	492.53
115.00	492.53	492.53	492.53	492.53	492.53
120.00	492.53	492.53	492.53	492.53	492.53
125.00	492.53	492.53	492.53	492.52	492.52
130.00	492.52	492.52	492.52	492.52	492.52
135.00	492.52	492.52	492.52	492.52	492.52
140.00	492.52	492.52	492.52	492.52	492.52
145.00	492.52	492.52	492.52	492.52	492.52
150.00	492.52	492.52	492.51	492.51	492.51
155.00	492.51	492.51	492.51	492.51	492.51
160.00	492.51	492.51	492.51	492.51	492.51
165.00	492.51	492.51	492.51	492.51	492.51
170.00	492.51	492.51	492.51	492.51	492.51
175.00	492.51	492.51	492.51	492.51	492.51
180.00	492.51	492.51	492.51	492.51	492.51
185.00	492.51	492.51	492.51	492.51	492.51
190.00	492.51	492.51	492.51	492.51	492.51
195.00	492.51	492.51	492.51	492.51	492.51
200.00	492.51	492.51	492.51	492.51	492.51
205.00	492.50	492.50	492.50	492.50	492.50
210.00	492.50	492.50	492.50	492.50	492.50

TIME vs. ELEVATION (ft)

Time min	Output Time increment = 1.00 min				
	Time on left represents time for first value in each row.				
215.00	492.50	492.50	492.50	492.50	492.50
220.00	492.50	492.50	492.50	492.50	492.50
225.00	492.50	492.50	492.50	492.50	492.50
230.00	492.50	492.50	492.50	492.50	492.50
235.00	492.50	492.50	492.50	492.50	492.50
240.00	492.50	492.50	492.50	492.50	492.50
245.00	492.50	492.50	492.50	492.50	492.50
250.00	492.50	492.50	492.50	492.50	492.50
255.00	492.50	492.50	492.50	492.50	492.50
260.00	492.50	492.50	492.50	492.50	492.50
265.00	492.50	492.50	492.50	492.50	492.50
270.00	492.50	492.50	492.50	492.50	492.50
275.00	492.50	492.50	492.50	492.50	492.50
280.00	492.50	492.50	492.50	492.50	492.50
285.00	492.50	492.50	492.50	492.50	492.50
290.00	492.50	492.50	492.50	492.50	492.50
295.00	492.50	492.50	492.50	492.50	492.50
300.00	492.50	492.50	492.50	492.50	492.50
305.00	492.50	492.50	492.50	492.50	492.50
310.00	492.50	492.50	492.50	492.50	492.50
315.00	492.50	492.50	492.50	492.50	492.50
320.00	492.50	492.50	492.50	492.50	492.50
325.00	492.50	492.50	492.50	492.50	492.50
330.00	492.50	492.50	492.50	492.50	492.50
335.00	492.50	492.50	492.50	492.50	492.50
340.00	492.50	492.50	492.50	492.50	492.50
345.00	492.50	492.50	492.50	492.50	492.50
350.00	492.50	492.50	492.50	492.50	492.50
355.00	492.50	492.50	492.50	492.50	492.50
360.00	492.50	492.50	492.50	492.50	492.50
365.00	492.50	492.50	492.50	492.50	492.50
370.00	492.50	492.50	492.50	492.50	492.50
375.00	492.50	492.50	492.50	492.50	492.50
380.00	492.50	492.50			

TIME vs. VOLUME (cu.ft)

Time min	Output Time increment = 1.00 min				
	Time on left represents time for first value in each row.				
.00	272543	272679	273849	275990	279034
5.00	282870	287402	292527	298116	303563
10.00	308334	312484	316067	319150	321793
15.00	324045	325965	327603	328986	330154
20.00	331143	331477	330756	329151	326788
25.00	323772	320205	316140	311635	307238
30.00	303404	300058	297108	294499	292188
35.00	290118	288262	286596	285096	283730
40.00	282486	281352	280316	279373	278508
45.00	277707	276961	276268	275623	275022
50.00	274461	273942	273457	273005	272585
55.00	272190	271815	271458	271117	270789
60.00	270475	270177	269890	269614	269351
65.00	269100	268859	268629	268408	268196
70.00	267993	267801	267614	267439	267269
75.00	267105	266950	266801	266658	266522
80.00	266392	266268	266148	266032	265922
85.00	265817	265718	265621	265528	265441
90.00	265356	265276	265197	265123	265053
95.00	264982	264914	264848	264784	264720
100.00	264656	264596	264537	264477	264419
105.00	264363	264307	264254	264202	264149
110.00	264099	264050	264000	263953	263905
115.00	263860	263816	263771	263730	263687
120.00	263645	263606	263567	263528	263489
125.00	263451	263416	263381	263346	263311
130.00	263278	263245	263214	263181	263151
135.00	263122	263093	263064	263035	263006
140.00	262979	262953	262928	262901	262876
145.00	262852	262829	262804	262782	262759
150.00	262738	262716	262695	262674	262654
155.00	262635	262615	262596	262578	262559
160.00	262541	262524	262508	262489	262473
165.00	262458	262442	262427	262411	262396
170.00	262382	262368	262353	262341	262326
175.00	262314	262302	262289	262277	262265
180.00	262252	262242	262230	262219	262207
185.00	262197	262186	262176	262166	262158
190.00	262147	262139	262129	262120	262110
195.00	262102	262094	262085	262077	262069
200.00	262063	262055	262046	262040	262032
205.00	262026	262020	262011	262005	261999
210.00	261993	261987	261980	261974	261968

TIME vs. VOLUME (cu.ft)

Time min	Output Time increment = 1.00 min				
	Time on left represents time for first value in each row.				
215.00	261964	261958	261952	261948	261941
220.00	261937	261931	261927	261923	261917
225.00	261913	261908	261904	261900	261896
230.00	261892	261888	261884	261880	261875
235.00	261871	261867	261865	261861	261857
240.00	261855	261851	261847	261845	261840
245.00	261838	261834	261832	261830	261826
250.00	261824	261822	261818	261816	261814
255.00	261812	261810	261806	261803	261801
260.00	261799	261797	261795	261793	261791
265.00	261789	261787	261785	261783	261781
270.00	261781	261779	261777	261775	261773
275.00	261771	261771	261768	261766	261764
280.00	261764	261762	261760	261760	261758
285.00	261756	261756	261754	261754	261752
290.00	261750	261750	261748	261748	261746
295.00	261746	261744	261744	261742	261742
300.00	261740	261740	261738	261738	261736
305.00	261736	261736	261733	261733	261731
310.00	261731	261731	261729	261729	261729
315.00	261727	261727	261727	261725	261725
320.00	261725	261723	261723	261723	261721
325.00	261721	261721	261721	261719	261719
330.00	261719	261719	261717	261717	261717
335.00	261717	261715	261715	261715	261715
340.00	261715	261713	261713	261713	261713
345.00	261713	261713	261711	261711	261711
350.00	261711	261711	261711	261709	261709
355.00	261709	261709	261709	261709	261707
360.00	261707	261707	261707	261707	261707
365.00	261707	261707	261705	261705	261705
370.00	261705	261705	261705	261705	261705
375.00	261705	261705	261703	261703	261703
380.00	261703	261703			

POND VOLUME CALCULATIONS

Planimeter scale: 1.00 ft/in

Elevation (ft)	Planimeter (sq.in)	Area (sq.ft)	A1+A2+sqr(A1*A2) (sq.ft)	Volume (cu.ft)	Volume Sum (cu.ft)
485.55	.000	0	0	0	0
488.00	30596.000	30596	30596	24987	24987
490.00	54535.000	54535	125979	83986	108973
492.00	65189.000	65189	179349	119566	228539
494.00	74425.000	74425	209268	139512	368051
495.00	75785.000	75785	225312	75104	443155

POND VOLUME EQUATIONS

* Incremental volume computed by the Conic Method for Reservoir Volumes.

$$\text{Volume} = (1/3) * (\text{EL2}-\text{EL1}) * (\text{Areal} + \text{Area2} + \text{sq.rt.}(\text{Areal}*\text{Area2}))$$

where: EL1, EL2 = Lower and upper elevations of the increment
 Areal,Area2 = Areas computed for EL1, EL2, respectively
 Volume = Incremental volume between EL1 and EL2

Name.... WEST

File.... H:\PONDPACK\9000PLUS\9203F-DATA\AS-BUILT ULTIMATE PHASE.MODIFIED BASIN.LFB.04.17.

REQUESTED POND WS ELEVATIONS:

Min. Elev.= 485.55 ft
 Increment = .10 ft
 Max. Elev.= 495.00 ft

OUTLET CONNECTIVITY

---> Forward Flow Only (UpStream to DnStream)
 <--- Reverse Flow Only (DnStream to UpStream)
 <---> Forward and Reverse Both Allowed

Structure	No.	Outfall	E1, ft	E2, ft
Stand Pipe	R0	---> TW	492.660	495.000
Weir-Rectangular	W1	---> TW	492.500	495.000
TW SETUP, DS Channel				

OUTLET STRUCTURE INPUT DATA

Structure ID = R0
Structure Type = Stand Pipe

of Openings = 1
Invert Elev. = 492.66 ft
Diameter = 3.5000 ft
Orifice Area = 9.6211 sq.ft
Orifice Coeff. = .600
Weir Length = 11.00 ft
Weir Coeff. = 3.000
K, Reverse = 1.000
Mannings n = .0000
Kev, Charged Riser = .000
Weir Submergence = No
Orifice H to crest = Yes

Structure ID = W1
Structure Type = Weir-Rectangular

of Openings = 1
Crest Elev. = 492.50 ft
Weir Length = 35.00 ft
Weir Coeff. = 3.000000

Weir TW effects (Use adjustment equation)

Structure ID = TW
Structure Type = TW SETUP, DS Channel

FREE OUTFALL CONDITIONS SPECIFIED

CONVERGENCE TOLERANCES...
Maximum Iterations = 40
Min. TW tolerance = .01 ft
Max. TW tolerance = .01 ft
Min. HW tolerance = .01 ft
Max. HW tolerance = .01 ft
Min. Q tolerance = .00 cfs
Max. Q tolerance = .00 cfs

***** COMPOSITE OUTFLOW SUMMARY *****

WS Elev, Total Q		Converge		Notes
Elev. ft	Q cfs	TW Elev ft	Error +/-ft	Contributing Structures
485.55	.00	Free	Outfall	None contributing
485.65	.00	Free	Outfall	None contributing
485.75	.00	Free	Outfall	None contributing
485.85	.00	Free	Outfall	None contributing
485.95	.00	Free	Outfall	None contributing
486.05	.00	Free	Outfall	None contributing
486.15	.00	Free	Outfall	None contributing
486.25	.00	Free	Outfall	None contributing
486.35	.00	Free	Outfall	None contributing
486.45	.00	Free	Outfall	None contributing
486.55	.00	Free	Outfall	None contributing
486.65	.00	Free	Outfall	None contributing
486.75	.00	Free	Outfall	None contributing
486.85	.00	Free	Outfall	None contributing
486.95	.00	Free	Outfall	None contributing
487.05	.00	Free	Outfall	None contributing
487.15	.00	Free	Outfall	None contributing
487.25	.00	Free	Outfall	None contributing
487.35	.00	Free	Outfall	None contributing
487.45	.00	Free	Outfall	None contributing
487.55	.00	Free	Outfall	None contributing
487.65	.00	Free	Outfall	None contributing
487.75	.00	Free	Outfall	None contributing
487.85	.00	Free	Outfall	None contributing
487.95	.00	Free	Outfall	None contributing
488.05	.00	Free	Outfall	None contributing
488.15	.00	Free	Outfall	None contributing
488.25	.00	Free	Outfall	None contributing
488.35	.00	Free	Outfall	None contributing
488.45	.00	Free	Outfall	None contributing
488.55	.00	Free	Outfall	None contributing
488.65	.00	Free	Outfall	None contributing
488.75	.00	Free	Outfall	None contributing
488.85	.00	Free	Outfall	None contributing
488.95	.00	Free	Outfall	None contributing
489.05	.00	Free	Outfall	None contributing
489.15	.00	Free	Outfall	None contributing
489.25	.00	Free	Outfall	None contributing

Name.... WEST MOD. LFB

File.... H:\PONDPACK\9000PLUS\9203F-DATA\AS-BUILT ULTIMATE PHASE.MODIFIED BASIN.LFB.04.17.

***** COMPOSITE OUTFLOW SUMMARY *****

WS Elev, Total Q		Converge		Notes
Elev. ft	Q cfs	TW Elev ft	Error +/-ft	Contributing Structures
489.35	.00	Free	Outfall	None contributing
489.45	.00	Free	Outfall	None contributing
489.55	.00	Free	Outfall	None contributing
489.65	.00	Free	Outfall	None contributing
489.75	.00	Free	Outfall	None contributing
489.85	.00	Free	Outfall	None contributing
489.95	.00	Free	Outfall	None contributing
490.05	.00	Free	Outfall	None contributing
490.15	.00	Free	Outfall	None contributing
490.25	.00	Free	Outfall	None contributing
490.35	.00	Free	Outfall	None contributing
490.45	.00	Free	Outfall	None contributing
490.55	.00	Free	Outfall	None contributing
490.65	.00	Free	Outfall	None contributing
490.75	.00	Free	Outfall	None contributing
490.85	.00	Free	Outfall	None contributing
490.95	.00	Free	Outfall	None contributing
491.05	.00	Free	Outfall	None contributing
491.15	.00	Free	Outfall	None contributing
491.25	.00	Free	Outfall	None contributing
491.35	.00	Free	Outfall	None contributing
491.45	.00	Free	Outfall	None contributing
491.55	.00	Free	Outfall	None contributing
491.65	.00	Free	Outfall	None contributing
491.75	.00	Free	Outfall	None contributing
491.85	.00	Free	Outfall	None contributing
491.95	.00	Free	Outfall	None contributing
492.05	.00	Free	Outfall	None contributing
492.15	.00	Free	Outfall	None contributing
492.25	.00	Free	Outfall	None contributing
492.35	.00	Free	Outfall	None contributing
492.45	.00	Free	Outfall	None contributing
492.50	.00	Free	Outfall	W1
492.55	1.17	Free	Outfall	W1
492.65	6.10	Free	Outfall	W1
492.66	6.72	Free	Outfall	R0 +W1
492.75	14.02	Free	Outfall	R0 +W1
492.85	24.47	Free	Outfall	R0 +W1

***** COMPOSITE OUTFLOW SUMMARY *****

WS Elev, Total Q		Converge		Notes
Elev. ft	Q cfs	TW Elev ft	Error +/-ft	Contributing Structures
492.95	36.85	Free	Outfall	R0 +W1
493.05	50.86	Free	Outfall	R0 +W1
493.15	66.34	Free	Outfall	R0 +W1
493.25	83.15	Free	Outfall	R0 +W1
493.35	101.19	Free	Outfall	R0 +W1
493.45	120.38	Free	Outfall	R0 +W1
493.55	140.67	Free	Outfall	R0 +W1
493.65	161.98	Free	Outfall	R0 +W1
493.75	184.28	Free	Outfall	R0 +W1
493.85	207.51	Free	Outfall	R0 +W1
493.95	231.66	Free	Outfall	R0 +W1
494.05	256.68	Free	Outfall	R0 +W1
494.15	279.07	Free	Outfall	R0 +W1
494.25	301.47	Free	Outfall	R0 +W1
494.35	324.40	Free	Outfall	R0 +W1
494.45	347.87	Free	Outfall	R0 +W1
494.55	371.85	Free	Outfall	R0 +W1
494.65	396.34	Free	Outfall	R0 +W1
494.75	421.32	Free	Outfall	R0 +W1
494.85	446.78	Free	Outfall	R0 +W1
494.95	472.73	Free	Outfall	R0 +W1
495.00	485.88	Free	Outfall	R0 +W1

Name.... WEST MOD. LFB

LEVEL POOL ROUTING DATA

HYG Dir = H:\PONDPACK\9000PLUS\9203F-DATA\
 Inflow HYG file = NONE STORED - WEST IN 2
 Outflow HYG file = NONE STORED - WEST OUT 2

Pond Node Data = WEST
 Pond Volume Data = WEST
 Pond Outlet Data = WEST MOD. LFB

No Infiltration

INITIAL CONDITIONS

 Starting WS Elev = 492.66 ft
 Starting Volume = 272543 cu.ft
 Starting Outflow = 6.72 cfs
 Starting Infiltr. = .00 cfs
 Starting Total Qout= 6.72 cfs
 Time Increment = 1.00 min

Elevation ft	Outflow cfs	Storage cu.ft	Area sq.ft	Infiltr. cfs	Q Total cfs	2S/t + O cfs
485.55	.00	0	0	.00	.00	.00
485.65	.00	2	51	.00	.00	.06
485.75	.00	14	204	.00	.00	.45
485.85	.00	46	459	.00	.00	1.53
485.95	.00	109	816	.00	.00	3.62
486.05	.00	212	1274	.00	.00	7.08
486.15	.00	367	1835	.00	.00	12.23
486.25	.00	583	2498	.00	.00	19.43
486.35	.00	870	3262	.00	.00	29.00
486.45	.00	1239	4129	.00	.00	41.29
486.55	.00	1699	5097	.00	.00	56.63
486.65	.00	2261	6168	.00	.00	75.38
486.75	.00	2936	7340	.00	.00	97.87
486.85	.00	3733	8614	.00	.00	124.42
486.95	.00	4662	9990	.00	.00	155.40
487.05	.00	5734	11469	.00	.00	191.14
487.15	.00	6959	13049	.00	.00	231.98
487.25	.00	8348	14731	.00	.00	278.25
487.35	.00	9909	16515	.00	.00	330.29
487.45	.00	11654	18401	.00	.00	388.46

Name.... WEST

File.... H:\PONDPACK\9000PLUS\9203F-DATA\AS-BUILT ULTIMATE PHASE.MODIFIED BASIN.LFB.04.17.

LEVEL POOL ROUTING DATA

HYG Dir = H:\PONDPACK\9000PLUS\9203F-DATA\
 Inflow HYG file = NONE STORED - WEST IN 2
 Outflow HYG file = NONE STORED - WEST OUT 2

Pond Node Data = WEST
 Pond Volume Data = WEST
 Pond Outlet Data = WEST MOD. LFB

No Infiltration

INITIAL CONDITIONS

 Starting WS Elev = 492.66 ft
 Starting Volume = 272543 cu.ft
 Starting Outflow = 6.72 cfs
 Starting Infiltr. = .00 cfs
 Starting Total Qout= 6.72 cfs
 Time Increment = 1.00 min

Elevation ft	Outflow cfs	Storage cu.ft	Area sq.ft	Infiltr. cfs	Q Total cfs	2S/t + O cfs
487.55	.00	13592	20389	.00	.00	453.08
487.65	.00	15735	22479	.00	.00	524.50
487.75	.00	18092	24671	.00	.00	603.06
487.85	.00	20672	26964	.00	.00	689.07
487.95	.00	23488	29359	.00	.00	782.92
488.05	.00	26529	31111	.00	.00	884.30
488.15	.00	29692	32153	.00	.00	989.74
488.25	.00	32961	33213	.00	.00	1098.69
488.35	.00	36335	34289	.00	.00	1211.16
488.45	.00	39819	35383	.00	.00	1327.28
488.55	.00	43412	36494	.00	.00	1447.08
488.65	.00	47118	37623	.00	.00	1570.61
488.75	.00	50938	38768	.00	.00	1697.93
488.85	.00	54872	39930	.00	.00	1829.06
488.95	.00	58924	41110	.00	.00	1964.13
489.05	.00	63095	42307	.00	.00	2103.16
489.15	.00	67386	43521	.00	.00	2246.21
489.25	.00	71800	44753	.00	.00	2393.34
489.35	.00	76337	46001	.00	.00	2544.55
489.45	.00	81000	47267	.00	.00	2700.00

Name.... WEST

File.... H:\PONDPACK\9000PLUS\9203F-DATA\AS-BUILT ULTIMATE PHASE.MODIFIED BASIN.LFB.04.17.

LEVEL POOL ROUTING DATA

HYG Dir = H:\PONDPACK\9000PLUS\9203F-DATA\
 Inflow HYG file = NONE STORED - WEST IN 2
 Outflow HYG file = NONE STORED - WEST OUT 2

Pond Node Data = WEST
 Pond Volume Data = WEST
 Pond Outlet Data = WEST MOD. LFB

No Infiltration

INITIAL CONDITIONS

 Starting WS Elev = 492.66 ft
 Starting Volume = 272543 cu.ft
 Starting Outflow = 6.72 cfs
 Starting Infiltr. = .00 cfs
 Starting Total Qout= 6.72 cfs
 Time Increment = 1.00 min

Elevation ft	Outflow cfs	Storage cu.ft	Area sq.ft	Infiltr. cfs	Q Total cfs	2S/t + O cfs
489.55	.00	85791	48550	.00	.00	2859.70
489.65	.00	90711	49850	.00	.00	3023.71
489.75	.00	95762	51167	.00	.00	3192.07
489.85	.00	100944	52501	.00	.00	3364.80
489.95	.00	106262	53853	.00	.00	3542.06
490.05	.00	111705	54790	.00	.00	3723.50
490.15	.00	117210	55301	.00	.00	3907.00
490.25	.00	122766	55815	.00	.00	4092.20
490.35	.00	128372	56331	.00	.00	4279.06
490.45	.00	134031	56849	.00	.00	4467.71
490.55	.00	139743	57370	.00	.00	4658.08
490.65	.00	145506	57893	.00	.00	4850.20
490.75	.00	151322	58419	.00	.00	5044.06
490.85	.00	157189	58947	.00	.00	5239.62
490.95	.00	163111	59477	.00	.00	5437.01
491.05	.00	169085	60010	.00	.00	5636.16
491.15	.00	175113	60545	.00	.00	5837.10
491.25	.00	181195	61082	.00	.00	6039.82
491.35	.00	187329	61622	.00	.00	6244.28
491.45	.00	193518	62164	.00	.00	6450.60

Name.... WEST

File.... H:\PONDPACK\9000PLUS\9203F-DATA\AS-BUILT ULTIMATE PHASE.MODIFIED BASIN.LFB.04.17.

LEVEL POOL ROUTING DATA

HYG Dir = H:\PONDPACK\9000PLUS\9203F-DATA\
 Inflow HYG file = NONE STORED - WEST IN 2
 Outflow HYG file = NONE STORED - WEST OUT 2

Pond Node Data = WEST
 Pond Volume Data = WEST
 Pond Outlet Data = WEST MOD. LFB

No Infiltration

INITIAL CONDITIONS

 Starting WS Elev = 492.66 ft
 Starting Volume = 272543 cu.ft
 Starting Outflow = 6.72 cfs
 Starting Infiltr. = .00 cfs
 Starting Total Qout= 6.72 cfs
 Time Increment = 1.00 min

Elevation ft	Outflow cfs	Storage cu.ft	Area sq.ft	Infiltr. cfs	Q Total cfs	2S/t + O cfs
491.55	.00	199763	62709	.00	.00	6658.74
491.65	.00	206061	63256	.00	.00	6868.69
491.75	.00	212415	63805	.00	.00	7080.47
491.85	.00	218821	64357	.00	.00	7294.02
491.95	.00	225285	64911	.00	.00	7509.48
492.05	.00	231803	65412	.00	.00	7726.74
492.15	.00	238367	65860	.00	.00	7945.54
492.25	.00	244976	66310	.00	.00	8165.84
492.35	.00	251628	66761	.00	.00	8387.57
492.45	.00	258327	67214	.00	.00	8610.87
492.50	.00	261694	67441	.00	.00	8723.13
492.55	1.17	265071	67668	.00	1.17	8836.86
492.65	6.10	271861	68124	.00	6.10	9068.12
492.66	6.72	272543	68169	.00	6.72	9091.48
492.75	14.02	278697	68581	.00	14.02	9303.89
492.85	24.47	285576	69039	.00	24.47	9543.66
492.95	36.85	292504	69500	.00	36.85	9786.94
493.05	50.86	299477	69962	.00	50.86	10033.41
493.15	66.34	306497	70425	.00	66.34	10282.87
493.25	83.15	313563	70890	.00	83.15	10535.22

Name.... WEST

File.... H:\PONDPACK\9000PLUS\9203F-DATA\AS-BUILT ULTIMATE PHASE.MODIFIED BASIN.LFB.04.17.

LEVEL POOL ROUTING DATA

HYG Dir = H:\PONDPACK\9000PLUS\9203F-DATA\
 Inflow HYG file = NONE STORED - WEST IN 2
 Outflow HYG file = NONE STORED - WEST OUT 2

Pond Node Data = WEST
 Pond Volume Data = WEST
 Pond Outlet Data = WEST MOD. LFB

No Infiltration

INITIAL CONDITIONS

 Starting WS Elev = 492.66 ft
 Starting Volume = 272543 cu.ft
 Starting Outflow = 6.72 cfs
 Starting Infiltr. = .00 cfs
 Starting Total Qout= 6.72 cfs
 Time Increment = 1.00 min

Elevation ft	Outflow cfs	Storage cu.ft	Area sq.ft	Infiltr. cfs	Q Total cfs	2S/t + O cfs
493.35	101.19	320673	71356	.00	101.19	10790.28
493.45	120.38	327833	71824	.00	120.38	11048.12
493.55	140.67	335039	72294	.00	140.67	11308.62
493.65	161.98	342293	72765	.00	161.98	11571.71
493.75	184.28	349593	73237	.00	184.28	11837.36
493.85	207.51	356939	73711	.00	207.51	12105.44
493.95	231.66	364334	74187	.00	231.66	12376.10
494.05	256.68	371773	74493	.00	256.68	12649.07
494.15	279.07	379229	74628	.00	279.07	12920.01
494.25	301.47	386699	74764	.00	301.47	13191.41
494.35	324.40	394181	74900	.00	324.40	13463.72
494.45	347.87	401678	75035	.00	347.87	13737.10
494.55	371.85	409189	75171	.00	371.85	14011.44
494.65	396.34	416713	75308	.00	396.34	14286.74
494.75	421.32	424251	75444	.00	421.32	14562.99
494.85	446.78	431800	75580	.00	446.78	14840.10
494.95	472.73	439366	75717	.00	472.73	15118.22
495.00	485.88	443155	75785	.00	485.88	15257.67

Name.... WEST

File.... H:\PONDPACK\9000PLUS\9203F-DATA\AS-BUILT ULTIMATE PHASE.MODIFIED BASIN.LFB.04.17.

SUMMARY FOR HYDROGRAPH ADDITION
at Node: WEST IN

HYG Directory: H:\PONDPACK\9000PLUS\9203F-DATA\

Upstream Link ID	Upstream Node ID	HYG file	HYG ID	HYG tag
WEST	WEST		100 W	

INFLOWS TO: WEST IN

HYG file	HYG ID	HYG tag	Volume cu.ft	Peak Time min	Peak Flow cfs
	100 W		173760	8.00	144.80

TOTAL FLOW INTO: WEST IN

HYG file	HYG ID	HYG tag	Volume cu.ft	Peak Time min	Peak Flow cfs
	WEST	IN 100	173760	8.00	144.80

Name.... WEST IN

Event: 100 yr

File.... H:\PONDPACK\9000PLUS\9203F-DATA\AS-BUILT ULTIMATE PHASE.MODIFIED BASIN.LFB.04.17.

Storm... 100 Tag: 100

TOTAL NODE INFLOW...

HYG file =

HYG ID = WEST IN

HYG Tag = 100

```

-----
Peak Discharge =      144.80 cfs
Time to Peak   =         8.00 min
HYG Volume     =     173760 cu.ft
-----

```

HYDROGRAPH ORDINATES (cfs)

Output Time increment = 1.00 min

Time min | Time on left represents time for first value in each row.

Time min					
.00	.00	18.10	36.20	54.30	72.40
5.00	90.50	108.60	126.70	144.80	144.80
10.00	144.80	144.80	144.80	144.80	144.80
15.00	144.80	144.80	144.80	144.80	144.80
20.00	144.80	126.70	108.60	90.50	72.40
25.00	54.30	36.20	18.10	.00	

LEVEL POOL ROUTING SUMMARY

HYG Dir = H:\PONDPACK\9000PLUS\9203F-DATA\
Inflow HYG file = NONE STORED - WEST IN 100
Outflow HYG file = NONE STORED - WEST OUT 100

Pond Node Data = WEST
Pond Volume Data = WEST
Pond Outlet Data = WEST MOD. LFB

No Infiltration

INITIAL CONDITIONS

Starting WS Elev = 492.66 ft
Starting Volume = 272543 cu.ft
Starting Outflow = 6.72 cfs
Starting Infiltr. = .00 cfs
Starting Total Qout= 6.72 cfs
Time Increment = 1.00 min

INFLOW/OUTFLOW HYDROGRAPH SUMMARY

Peak Inflow = 144.80 cfs at 8.00 min
Peak Outflow = 130.66 cfs at 21.00 min
Peak Elevation = 493.50 ft
Peak Storage = 331477 cu.ft

MASS BALANCE (cu.ft)

+ Initial Vol = 272543
+ HYG Vol IN = 173760
- Infiltration = 0
- HYG Vol OUT = 184601
- Retained Vol = 261703
Unrouted Vol = -1 cu.ft (.000% of Outflow Volume)

----- W -----

WEST... 4.01, 6.01, 6.06, 2.01,
 3.01, 6.08

WEST MOD. LFB... 5.01, 5.03

STORMWATER DETENTION CALCULATIONS

ULTIMATE DEVELOPMENT

EAST BASIN

100 YR. LOW FLOW BLOCKED

Table of Contents

***** NETWORK SUMMARIES (DETAILED) *****

Watershed..... 100
Executive Summary (Nodes) 1.01

***** TIME VS.ELEV *****

EAST OUT 100
Time-Elev 2.01

***** TIME VS.VOL *****

EAST OUT 100
Time vs. Volume 3.01

***** POND VOLUMES *****

EAST..... Vol: Planimeter 4.01

***** OUTLET STRUCTURES *****

EAST MOD. LFB... Outlet Input Data 5.01
Composite Rating Curve 5.03

***** POND ROUTING *****

EAST..... Pond E-V-Q Table 6.01

Table of Contents

EAST	IN 100	
	Node: Pond Inflow Summary	6.06
EAST	OUT 100	
	Pond Routing Summary	6.08

Table of Contents (continued)

NETWORK SUMMARY -- NODES
 (Trun.= HYG Truncation: Blank=None; L=Left; R=Rt; LR=Left & Rt)

Node ID	Type	HYG Vol cu.ft	Trun.	Qpeak min	Qpeak cfs	Max WSEL ft
EAST	HYG	162000		12.00	135.00	
Outfall EAST	JCT	161997		20.00	130.16	
EAST	IN POND	162000		12.00	135.00	
EAST	OUT POND	161997		20.00	130.16	484.22
WEST	HYG	173760		8.00	144.80	
Outfall WEST	JCT	184601	L	21.00	130.66	
WEST	IN POND	173760		8.00	144.80	
WEST	OUT POND	184601	L	21.00	130.66	493.50

TIME vs. ELEVATION (ft)

Output Time increment = 1.00 min
 Time on left represents time for first value in each row.

Time min					
.00	482.24	482.27	482.34	482.46	482.60
5.00	482.76	482.92	483.08	483.24	483.39
10.00	483.54	483.68	483.81	483.93	484.01
15.00	484.07	484.12	484.15	484.18	484.20
20.00	484.22	484.21	484.18	484.13	484.06
25.00	483.98	483.89	483.78	483.67	483.55
30.00	483.42	483.29	483.14	483.00	482.89
35.00	482.80	482.73	482.66	482.61	482.57
40.00	482.53	482.50	482.48	482.45	482.43
45.00	482.41	482.40	482.39	482.37	482.36
50.00	482.35	482.35	482.34	482.33	482.32
55.00	482.32	482.31	482.31	482.30	482.30
60.00	482.30	482.29	482.29	482.29	482.29
65.00	482.28	482.28	482.28	482.28	482.28
70.00	482.27	482.27	482.27	482.27	482.27
75.00	482.27	482.27	482.26	482.26	482.26
80.00	482.26	482.26	482.26	482.26	482.26
85.00	482.26	482.26	482.25	482.25	482.25
90.00	482.25	482.25	482.25	482.25	482.25
95.00	482.25	482.25	482.25	482.25	482.25
100.00	482.25	482.25	482.25	482.25	482.25
105.00	482.25	482.25	482.25	482.24	482.24
110.00	482.24	482.24	482.24	482.24	482.24
115.00	482.24	482.24	482.24	482.24	482.24
120.00	482.24	482.24	482.24	482.24	482.24
125.00	482.24	482.24	482.24	482.24	482.24
130.00	482.24	482.24	482.24	482.24	482.24
135.00	482.24	482.24	482.24	482.24	482.24
140.00	482.24	482.24	482.24	482.24	482.24
145.00	482.24	482.24	482.24	482.24	482.24
150.00	482.24	482.24	482.24	482.24	482.24
155.00	482.24	482.24	482.24	482.24	482.24
160.00	482.24	482.24	482.24	482.24	482.24

TIME vs. VOLUME (cu.ft)

Time min	Output Time increment = 1.00 min				
	Time on left represents time for first value in each row.				
.00	22865	23193	24143	25634	27546
5.00	29747	32139	34644	37194	39769
10.00	42329	44882	47406	49611	51281
15.00	52537	53479	54186	54718	55124
20.00	55446	55404	54763	53671	52263
25.00	50613	48779	46799	44707	42526
30.00	40272	37957	35567	33418	31731
35.00	30389	29310	28437	27720	27128
40.00	26631	26217	25863	25557	25295
45.00	25069	24874	24704	24551	24413
50.00	24290	24179	24079	23989	23909
55.00	23837	23772	23713	23661	23613
60.00	23571	23533	23498	23467	23436
65.00	23408	23381	23355	23330	23307
70.00	23285	23264	23244	23225	23207
75.00	23190	23173	23158	23144	23130
80.00	23116	23104	23092	23081	23070
85.00	23060	23050	23041	23032	23024
90.00	23016	23008	23001	22994	22988
95.00	22982	22976	22970	22965	22960
100.00	22955	22951	22947	22943	22939
105.00	22935	22932	22928	22925	22922
110.00	22919	22917	22914	22912	22909
115.00	22907	22905	22903	22901	22899
120.00	22898	22896	22895	22893	22892
125.00	22890	22889	22888	22887	22886
130.00	22885	22884	22883	22882	22881
135.00	22880	22880	22879	22878	22878
140.00	22877	22877	22876	22875	22875
145.00	22874	22874	22874	22873	22873
150.00	22872	22872	22872	22871	22871
155.00	22871	22871	22870	22870	22870
160.00	22869	22869	22869	22869	22869

POND VOLUME CALCULATIONS

Planimeter scale: 1.00 ft/in

Elevation (ft)	Planimeter (sq.in)	Area (sq.ft)	A1+A2+sqr(A1*A2) (sq.ft)	Volume (cu.ft)	Volume Sum (cu.ft)
477.19	.000	0	0	0	0
478.00	605.000	605	605	163	163
480.00	4509.000	4509	6766	4510	4674
482.00	11365.000	11365	23033	15355	20029
484.00	20067.000	20067	46534	31022	51051
485.00	22444.000	22444	63733	21244	72296
485.50	23656.000	23656	69142	11524	83819

POND VOLUME EQUATIONS

* Incremental volume computed by the Conic Method for Reservoir Volumes.

$$\text{Volume} = (1/3) * (\text{EL2}-\text{EL1}) * (\text{Area1} + \text{Area2} + \text{sq.rt.}(\text{Area1}*\text{Area2}))$$

where: EL1, EL2 = Lower and upper elevations of the increment
 Area1,Area2 = Areas computed for EL1, EL2, respectively
 Volume = Incremental volume between EL1 and EL2

REQUESTED POND WS ELEVATIONS:

Min. Elev.= 477.19 ft
 Increment = .10 ft
 Max. Elev.= 485.50 ft

 OUTLET CONNECTIVITY

----> Forward Flow Only (UpStream to DnStream)
 <---- Reverse Flow Only (DnStream to UpStream)
 <----> Forward and Reverse Both Allowed

Structure	No.	Outfall	E1, ft	E2, ft
Stand Pipe	R0	----> TW	482.240	485.500
TW SETUP, DS Channel				

Name.... EAST MOD. LFB

File.... H:\PONDPACK\9000PLUS\9203F-DATA\AS-BUILT ULTIMATE PHASE.MODIFIED BASIN.LFB.04.17.

OUTLET STRUCTURE INPUT DATA

Structure ID = R0
Structure Type = Stand Pipe

of Openings = 1
Invert Elev. = 482.24 ft
Diameter = 5.0000 ft
Orifice Area = 19.6350 sq.ft
Orifice Coeff. = .600
Weir Length = 15.71 ft
Weir Coeff. = 3.000
K, Reverse = 1.000
Mannings n = .0000
Kev,Charged Riser = .000
Weir Submergence = No
Orifice H to crest= Yes

Structure ID = TW
Structure Type = TW SETUP, DS Channel

FREE OUTFALL CONDITIONS SPECIFIED

CONVERGENCE TOLERANCES...
Maximum Iterations= 40
Min. TW tolerance = .01 ft
Max. TW tolerance = .01 ft
Min. HW tolerance = .01 ft
Max. HW tolerance = .01 ft
Min. Q tolerance = .00 cfs
Max. Q tolerance = .00 cfs

***** COMPOSITE OUTFLOW SUMMARY *****

WS Elev, Total Q		Converge		Notes
Elev. ft	Q cfs	TW Elev ft	Error +/-ft	Contributing Structures
477.19	.00	Free	Outfall	None contributing
477.29	.00	Free	Outfall	None contributing
477.39	.00	Free	Outfall	None contributing
477.49	.00	Free	Outfall	None contributing
477.59	.00	Free	Outfall	None contributing
477.69	.00	Free	Outfall	None contributing
477.79	.00	Free	Outfall	None contributing
477.89	.00	Free	Outfall	None contributing
477.99	.00	Free	Outfall	None contributing
478.09	.00	Free	Outfall	None contributing
478.19	.00	Free	Outfall	None contributing
478.29	.00	Free	Outfall	None contributing
478.39	.00	Free	Outfall	None contributing
478.49	.00	Free	Outfall	None contributing
478.59	.00	Free	Outfall	None contributing
478.69	.00	Free	Outfall	None contributing
478.79	.00	Free	Outfall	None contributing
478.89	.00	Free	Outfall	None contributing
478.99	.00	Free	Outfall	None contributing
479.09	.00	Free	Outfall	None contributing
479.19	.00	Free	Outfall	None contributing
479.29	.00	Free	Outfall	None contributing
479.39	.00	Free	Outfall	None contributing
479.49	.00	Free	Outfall	None contributing
479.59	.00	Free	Outfall	None contributing
479.69	.00	Free	Outfall	None contributing
479.79	.00	Free	Outfall	None contributing
479.89	.00	Free	Outfall	None contributing
479.99	.00	Free	Outfall	None contributing
480.09	.00	Free	Outfall	None contributing
480.19	.00	Free	Outfall	None contributing
480.29	.00	Free	Outfall	None contributing
480.39	.00	Free	Outfall	None contributing
480.49	.00	Free	Outfall	None contributing
480.59	.00	Free	Outfall	None contributing
480.69	.00	Free	Outfall	None contributing
480.79	.00	Free	Outfall	None contributing
480.89	.00	Free	Outfall	None contributing

Name.... EAST MOD. LFB

File.... H:\PONDPACK\9000PLUS\9203F-DATA\AS-BUILT ULTIMATE PHASE.MODIFIED BASIN.LFB.04.17.

***** COMPOSITE OUTFLOW SUMMARY *****

WS Elev, Total Q		Converge		Notes
Elev. ft	Q cfs	TW Elev ft	Error +/-ft	Contributing Structures
480.99	.00	Free	Outfall	None contributing
481.09	.00	Free	Outfall	None contributing
481.19	.00	Free	Outfall	None contributing
481.29	.00	Free	Outfall	None contributing
481.39	.00	Free	Outfall	None contributing
481.49	.00	Free	Outfall	None contributing
481.59	.00	Free	Outfall	None contributing
481.69	.00	Free	Outfall	None contributing
481.79	.00	Free	Outfall	None contributing
481.89	.00	Free	Outfall	None contributing
481.99	.00	Free	Outfall	None contributing
482.09	.00	Free	Outfall	None contributing
482.19	.00	Free	Outfall	None contributing
482.24	.00	Free	Outfall	R0
482.29	.53	Free	Outfall	R0
482.39	2.74	Free	Outfall	R0
482.49	5.89	Free	Outfall	R0
482.59	9.76	Free	Outfall	R0
482.69	14.23	Free	Outfall	R0
482.79	19.22	Free	Outfall	R0
482.89	24.70	Free	Outfall	R0
482.99	30.61	Free	Outfall	R0
483.09	36.93	Free	Outfall	R0
483.19	43.63	Free	Outfall	R0
483.29	50.70	Free	Outfall	R0
483.39	58.12	Free	Outfall	R0
483.49	65.86	Free	Outfall	R0
483.59	73.92	Free	Outfall	R0
483.69	82.28	Free	Outfall	R0
483.79	90.94	Free	Outfall	R0
483.89	99.88	Free	Outfall	R0
483.99	109.09	Free	Outfall	R0
484.09	118.58	Free	Outfall	R0
484.19	128.32	Free	Outfall	R0
484.29	135.31	Free	Outfall	R0
484.39	138.57	Free	Outfall	R0
484.49	141.76	Free	Outfall	R0
484.59	144.87	Free	Outfall	R0

***** COMPOSITE OUTFLOW SUMMARY *****

WS Elev, Total Q		Converge		Notes
Elev.	Q	TW Elev	Error	Contributing Structures
ft	cfs	ft	+/-ft	
484.69	147.92	Free	Outfall	R0
484.79	150.91	Free	Outfall	R0
484.89	153.84	Free	Outfall	R0
484.99	156.72	Free	Outfall	R0
485.09	159.54	Free	Outfall	R0
485.19	162.32	Free	Outfall	R0
485.29	165.04	Free	Outfall	R0
485.39	167.73	Free	Outfall	R0
485.49	170.37	Free	Outfall	R0
485.50	170.63	Free	Outfall	R0

Name.... EAST MOD. LFB

LEVEL POOL ROUTING DATA

HYG Dir = H:\PONDPACK\9000PLUS\9203F-DATA\
 Inflow HYG file = NONE STORED - EAST IN 2
 Outflow HYG file = NONE STORED - EAST OUT 2

Pond Node Data = EAST
 Pond Volume Data = EAST
 Pond Outlet Data = EAST MOD. LFB

No Infiltration

INITIAL CONDITIONS

 Starting WS Elev = 482.24 ft
 Starting Volume = 22865 cu.ft
 Starting Outflow = .00 cfs
 Starting Infiltr. = .00 cfs
 Starting Total Qout= .00 cfs
 Time Increment = 1.00 min

Elevation ft	Outflow cfs	Storage cu.ft	Area sq.ft	Infilt. cfs	Q Total cfs	2S/t + O cfs
477.19	.00	0	0	.00	.00	.00
477.29	.00	0	9	.00	.00	.01
477.39	.00	2	37	.00	.00	.08
477.49	.00	8	83	.00	.00	.28
477.59	.00	20	148	.00	.00	.66
477.69	.00	38	231	.00	.00	1.28
477.79	.00	66	332	.00	.00	2.21
477.89	.00	105	452	.00	.00	3.51
477.99	.00	157	590	.00	.00	5.25
478.09	.00	222	703	.00	.00	7.40
478.19	.00	298	820	.00	.00	9.94
478.29	.00	386	947	.00	.00	12.88
478.39	.00	488	1082	.00	.00	16.26
478.49	.00	603	1227	.00	.00	20.11
478.59	.00	733	1380	.00	.00	24.45
478.69	.00	880	1543	.00	.00	29.32
478.79	.00	1042	1714	.00	.00	34.74
478.89	.00	1223	1895	.00	.00	40.76
478.99	.00	1422	2085	.00	.00	47.39
479.09	.00	1640	2284	.00	.00	54.67

Name.... EAST

File.... H:\PONDPACK\9000PLUS\9203F-DATA\AS-BUILT ULTIMATE PHASE.MODIFIED BASIN.LFB.04.17.

LEVEL POOL ROUTING DATA

HYG Dir = H:\PONDPACK\9000PLUS\9203F-DATA\
 Inflow HYG file = NONE STORED - EAST IN 2
 Outflow HYG file = NONE STORED - EAST OUT 2

Pond Node Data = EAST
 Pond Volume Data = EAST
 Pond Outlet Data = EAST MOD. LFB

No Infiltration

INITIAL CONDITIONS

 Starting WS Elev = 482.24 ft
 Starting Volume = 22865 cu.ft
 Starting Outflow = .00 cfs
 Starting Infiltr. = .00 cfs
 Starting Total Qout= .00 cfs
 Time Increment = 1.00 min

Elevation ft	Outflow cfs	Storage cu.ft	Area sq.ft	Infiltr. cfs	Q Total cfs	2S/t + O cfs
479.19	.00	1879	2492	.00	.00	62.62
479.29	.00	2139	2708	.00	.00	71.29
479.39	.00	2421	2934	.00	.00	80.69
479.49	.00	2726	3169	.00	.00	90.86
479.59	.00	3055	3414	.00	.00	101.83
479.69	.00	3409	3667	.00	.00	113.63
479.79	.00	3789	3929	.00	.00	126.28
479.89	.00	4195	4200	.00	.00	139.83
479.99	.00	4629	4480	.00	.00	154.29
480.09	.00	5090	4751	.00	.00	169.68
480.19	.00	5579	5026	.00	.00	185.97
480.29	.00	6096	5310	.00	.00	203.20
480.39	.00	6642	5602	.00	.00	221.39
480.49	.00	7216	5901	.00	.00	240.55
480.59	.00	7822	6208	.00	.00	260.73
480.69	.00	8458	6523	.00	.00	281.94
480.79	.00	9127	6845	.00	.00	304.22
480.89	.00	9828	7175	.00	.00	327.59
480.99	.00	10562	7513	.00	.00	352.06
481.09	.00	11331	7859	.00	.00	377.68

Name.... EAST

File.... H:\PONDPACK\9000PLUS\9203F-DATA\AS-BUILT ULTIMATE PHASE.MODIFIED BASIN.LFB.04.17.

LEVEL POOL ROUTING DATA

HYG Dir = H:\PONDPACK\9000PLUS\9203F-DATA\
 Inflow HYG file = NONE STORED - EAST IN 2
 Outflow HYG file = NONE STORED - EAST OUT 2

Pond Node Data = EAST
 Pond Volume Data = EAST
 Pond Outlet Data = EAST MOD. LFB

No Infiltration

INITIAL CONDITIONS

 Starting WS Elev = 482.24 ft
 Starting Volume = 22865 cu.ft
 Starting Outflow = .00 cfs
 Starting Infiltr. = .00 cfs
 Starting Total Qout= .00 cfs
 Time Increment = 1.00 min

Elevation ft	Outflow cfs	Storage cu.ft	Area sq.ft	Infilt. cfs	Q Total cfs	2S/t + O cfs
481.19	.00	12134	8213	.00	.00	404.47
481.29	.00	12974	8575	.00	.00	432.45
481.39	.00	13849	8944	.00	.00	461.65
481.49	.00	14762	9321	.00	.00	492.08
481.59	.00	15714	9706	.00	.00	523.79
481.69	.00	16704	10098	.00	.00	556.80
481.79	.00	17734	10499	.00	.00	591.13
481.89	.00	18804	10907	.00	.00	626.80
481.99	.00	19915	11323	.00	.00	663.84
482.09	.00	21067	11704	.00	.00	702.23
482.19	.00	22256	12086	.00	.00	741.88
482.24	.00	22865	12279	.00	.00	762.18
482.29	.53	23484	12475	.00	.53	783.34
482.39	2.74	24752	12869	.00	2.74	827.79
482.49	5.89	26058	13270	.00	5.89	874.49
482.59	9.76	27406	13677	.00	9.76	923.27
482.69	14.23	28794	14090	.00	14.23	974.02
482.79	19.22	30224	14509	.00	19.22	1026.68
482.89	24.70	31696	14934	.00	24.70	1081.23
482.99	30.61	33211	15365	.00	30.61	1137.62

Name.... EAST

File.... H:\PONDPACK\9000PLUS\9203F-DATA\AS-BUILT ULTIMATE PHASE.MODIFIED BASIN.LFB.04.17.

LEVEL POOL ROUTING DATA

HYG Dir = H:\PONDPACK\9000PLUS\9203F-DATA\
 Inflow HYG file = NONE STORED - EAST IN 2
 Outflow HYG file = NONE STORED - EAST OUT 2

Pond Node Data = EAST
 Pond Volume Data = EAST
 Pond Outlet Data = EAST MOD. LFB

No Infiltration

INITIAL CONDITIONS

 Starting WS Elev = 482.24 ft
 Starting Volume = 22865 cu.ft
 Starting Outflow = .00 cfs
 Starting Infiltr. = .00 cfs
 Starting Total Qout= .00 cfs
 Time Increment = 1.00 min

Elevation ft	Outflow cfs	Storage cu.ft	Area sq.ft	Infilt. cfs	Q Total cfs	2S/t + O cfs
483.09	36.93	34769	15803	.00	36.93	1195.89
483.19	43.63	36372	16247	.00	43.63	1256.02
483.29	50.70	38019	16697	.00	50.70	1317.99
483.39	58.12	39711	17153	.00	58.12	1381.82
483.49	65.86	41449	17615	.00	65.86	1447.49
483.59	73.92	43234	18083	.00	73.92	1515.05
483.69	82.28	45066	18557	.00	82.28	1584.48
483.79	90.94	46946	19038	.00	90.94	1655.80
483.89	99.88	48874	19525	.00	99.88	1729.01
483.99	109.09	50851	20017	.00	109.09	1804.11
484.09	118.58	52867	20275	.00	118.58	1880.79
484.19	128.32	54906	20508	.00	128.32	1958.52
484.29	135.31	56969	20743	.00	135.31	2034.26
484.39	138.57	59055	20978	.00	138.57	2107.06
484.49	141.76	61164	21215	.00	141.76	2180.55
484.59	144.87	63297	21453	.00	144.87	2254.78
484.69	147.92	65455	21693	.00	147.92	2329.75
484.79	150.91	67636	21934	.00	150.91	2405.45
484.89	153.84	69842	22176	.00	153.84	2481.90
484.99	156.72	72071	22420	.00	156.72	2559.08

Name.... EAST

File.... H:\PONDPACK\9000PLUS\9203F-DATA\AS-BUILT ULTIMATE PHASE.MODIFIED BASIN.LFB.04.17.

LEVEL POOL ROUTING DATA

HYG Dir = H:\PONDPACK\9000PLUS\9203F-DATA\
 Inflow HYG file = NONE STORED - EAST IN 2
 Outflow HYG file = NONE STORED - EAST OUT 2

Pond Node Data = EAST
 Pond Volume Data = EAST
 Pond Outlet Data = EAST MOD. LFB

No Infiltration

INITIAL CONDITIONS

 Starting WS Elev = 482.24 ft
 Starting Volume = 22865 cu.ft
 Starting Outflow = .00 cfs
 Starting Infiltr. = .00 cfs
 Starting Total Qout= .00 cfs
 Time Increment = 1.00 min

Elevation ft	Outflow cfs	Storage cu.ft	Area sq.ft	Infilt. cfs	Q Total cfs	2S/t + O cfs
485.09	159.54	74325	22660	.00	159.54	2637.05
485.19	162.32	76603	22901	.00	162.32	2715.76
485.29	165.04	78906	23143	.00	165.04	2795.23
485.39	167.73	81232	23387	.00	167.73	2875.47
485.49	170.37	83583	23631	.00	170.37	2956.45
485.50	170.63	83819	23656	.00	170.63	2964.60

Name.... EAST

File.... H:\PONDPACK\9000PLUS\9203F-DATA\AS-BUILT ULTIMATE PHASE.MODIFIED BASIN.LFB.04.17.

SUMMARY FOR HYDROGRAPH ADDITION
at Node: EAST IN

HYG Directory: H:\PONDPACK\9000PLUS\9203F-DATA\

Upstream Link ID	Upstream Node ID	HYG file	HYG ID	HYG tag
EAST	EAST		100 E	

INFLOWS TO: EAST IN

HYG file	HYG ID	HYG tag	Volume cu.ft	Peak Time min	Peak Flow cfs
	100 E		162000	12.00	135.00

TOTAL FLOW INTO: EAST IN

HYG file	HYG ID	HYG tag	Volume cu.ft	Peak Time min	Peak Flow cfs
	EAST	IN 100	162000	12.00	135.00

TOTAL NODE INFLOW...

HYG file =

HYG ID = EAST IN

HYG Tag = 100

```

-----
Peak Discharge =      135.00 cfs
Time to Peak   =       12.00 min
HYG Volume     =     162000 cu.ft
-----

```

HYDROGRAPH ORDINATES (cfs)

Output Time increment = 1.00 min

Time on left represents time for first value in each row.

Time min					
.00	.00	11.25	22.50	33.75	45.00
5.00	56.25	67.50	78.75	90.00	101.25
10.00	112.50	123.75	135.00	135.00	135.00
15.00	135.00	135.00	135.00	135.00	135.00
20.00	135.00	123.75	112.50	101.25	90.00
25.00	78.75	67.50	56.25	45.00	33.75
30.00	22.50	11.25	.00		

LEVEL POOL ROUTING SUMMARY

HYG Dir = H:\PONDPACK\9000PLUS\9203F-DATA\
Inflow HYG file = NONE STORED - EAST IN 100
Outflow HYG file = NONE STORED - EAST OUT 100

Pond Node Data = EAST
Pond Volume Data = EAST
Pond Outlet Data = EAST MOD. LFB

No Infiltration

INITIAL CONDITIONS

Starting WS Elev = 482.24 ft
Starting Volume = 22865 cu.ft
Starting Outflow = .00 cfs
Starting Infiltr. = .00 cfs
Starting Total Qout= .00 cfs
Time Increment = 1.00 min

INFLOW/OUTFLOW HYDROGRAPH SUMMARY

=====
Peak Inflow = 135.00 cfs at 12.00 min
Peak Outflow = 130.16 cfs at 20.00 min

Peak Elevation = 484.22 ft
Peak Storage = 55446 cu.ft
=====

MASS BALANCE (cu.ft)

+ Initial Vol = 22865
+ HYG Vol IN = 162000
- Infiltration = 0
- HYG Vol OUT = 161997
- Retained Vol = 22869

Unrouted Vol = - cu.ft (.000% of Inflow Volume)

Type.... Pond Routing Summary

Page 6.08

Name.... EAST OUT Tag: 100

Event: 100 yr

File.... H:\PONDPACK\9000PLUS\9203F-DATA\AS-BUILT ULTIMATE PHASE.MODIFIED BASIN.LFB.04.17.

----- E -----

EAST... 4.01, 6.01, 6.06, 2.01,
 3.01, 6.08

EAST MOD. LFB... 5.01, 5.03, 1.01

STORMWATER DETENTION CALCULATIONS

PROPOSED DEVELOPMENT

WEST BASIN

Table of Contents

***** NETWORK SUMMARIES (DETAILED) *****

Watershed..... 2
 Executive Summary (Nodes) 1.01

Watershed..... 15
 Executive Summary (Nodes) 1.02

Watershed..... 25
 Executive Summary (Nodes) 1.03

***** TIME VS.ELEV *****

WEST OUT 2
 Time-Elev 2.01

WEST OUT 15
 Time-Elev 2.02

WEST OUT 25
 Time-Elev 2.04

***** TIME VS.VOL *****

WEST OUT 2
 Time vs. Volume 3.01

WEST OUT 15
 Time vs. Volume 3.02

WEST OUT 25
 Time vs. Volume 3.04

***** POND VOLUMES *****

WEST..... Vol: Planimeter 4.01

Table of Contents

***** OUTLET STRUCTURES *****

WEST MODIFIED...	Outlet Input Data	5.01
	Composite Rating Curve	5.04

***** POND ROUTING *****

WEST.....	Pond E-V-Q Table	6.01
WEST	IN 2	
	Node: Pond Inflow Summary	6.06
WEST	IN 15	
	Node: Pond Inflow Summary	6.08
WEST	IN 25	
	Node: Pond Inflow Summary	6.10
WEST	OUT 2	
	Pond Routing Summary	6.12
WEST	OUT 15	
	Pond Routing Summary	6.13
WEST	OUT 25	
	Pond Routing Summary	6.14

Table of Contents (continued)

NETWORK SUMMARY -- NODES
 (Trun.= HYG Truncation: Blank=None; L=Left; R=Rt; LR=Left & Rt)

Node ID	Type	HYG Vol cu.ft	Qpeak Trun. min	Qpeak cfs	Max WSEL ft
-----	-----	-----	-----	-----	-----
Outfall EAST	HYG	37512	12.00	31.26	
EAST	JCT	37512	20.00	30.96	
EAST	IN POND	37512	12.00	31.26	
EAST	OUT POND	37512	20.00	30.96	480.19
WEST	HYG	38458	8.00	32.05	
Outfall WEST	JCT	38458	26.00	5.85	
WEST	IN POND	38458	8.00	32.05	
WEST	OUT POND	38458	26.00	5.85	488.19

NETWORK SUMMARY -- NODES

(Trun.= HYG Truncation: Blank=None; L=Left; R=Rt; LR=Left & Rt)

Node ID	Type	HYG Vol cu.ft	Trun.	Qpeak min	Qpeak cfs	Max WSEL ft
EAST	HYG	60883		12.00	50.74	
Outfall EAST	JCT	60883		22.00	41.46	
EAST	IN POND	60883		12.00	50.74	
EAST	OUT POND	60883		22.00	41.46	481.38
WEST	HYG	62544		8.00	52.12	
Outfall WEST	JCT	62544		27.00	6.66	
WEST	IN POND	62544		8.00	52.12	
WEST	OUT POND	62544		27.00	6.66	488.83

NETWORK SUMMARY -- NODES

(Trun.= HYG Truncation: Blank=None; L=Left; R=Rt; LR=Left & Rt)

Node ID	Type	HYG Vol cu.ft	Trun.	Qpeak min	Qpeak cfs	Max WSEL ft
EAST	HYG	76738		12.00	63.95	
Outfall EAST	JCT	76738		23.00	46.92	
EAST	IN POND	76738		12.00	63.95	
EAST	OUT POND	76738		23.00	46.92	482.14
WEST	HYG	79325		8.00	66.10	
Outfall WEST	JCT	79325		27.00	7.11	
WEST	IN POND	79325		8.00	66.10	
WEST	OUT POND	79325		27.00	7.11	489.22

TIME vs. ELEVATION (ft)

Time min	Output Time increment = 1.00 min				
	Time on left represents time for first value in each row.				
.00	485.55	485.94	486.17	486.36	486.53
5.00	486.69	486.84	486.98	487.12	487.24
10.00	487.35	487.44	487.53	487.61	487.68
15.00	487.75	487.81	487.87	487.93	487.98
20.00	488.03	488.08	488.12	488.15	488.17
25.00	488.19	488.19	488.19	488.19	488.18
30.00	488.17	488.16	488.14	488.13	488.12
35.00	488.11	488.10	488.09	488.08	488.07
40.00	488.06	488.05	488.04	488.02	488.01
45.00	488.00	487.99	487.98	487.97	487.96
50.00	487.95	487.94	487.92	487.91	487.90
55.00	487.89	487.88	487.87	487.86	487.84
60.00	487.83	487.82	487.81	487.79	487.78
65.00	487.77	487.76	487.74	487.73	487.72
70.00	487.71	487.69	487.68	487.67	487.65
75.00	487.64	487.63	487.61	487.60	487.58
80.00	487.57	487.56	487.54	487.53	487.51
85.00	487.50	487.48	487.47	487.45	487.44
90.00	487.42	487.40	487.39	487.37	487.36
95.00	487.34	487.32	487.31	487.29	487.27
100.00	487.25	487.24	487.22	487.20	487.18
105.00	487.16	487.14	487.12	487.10	487.08
110.00	487.06	487.04	487.02	487.00	486.98
115.00	486.95	486.93	486.91	486.88	486.86
120.00	486.84	486.81	486.78	486.76	486.73
125.00	486.70	486.67	486.64	486.61	486.58
130.00	486.55	486.51	486.48	486.45	486.42
135.00	486.39	486.36	486.32	486.29	486.26
140.00	486.22	486.18	486.15	486.11	486.07
145.00	486.03	485.98	485.94	485.89	485.84
150.00	485.78	485.71	485.64	485.55	

TIME vs. ELEVATION (ft)

Time min	Output Time increment = 1.00 min Time on left represents time for first value in each row.				
.00	485.55	486.01	486.29	486.52	486.72
5.00	486.91	487.09	487.26	487.42	487.57
10.00	487.70	487.81	487.91	488.01	488.10
15.00	488.18	488.27	488.35	488.43	488.51
20.00	488.58	488.65	488.71	488.75	488.79
25.00	488.81	488.83	488.83	488.83	488.82
30.00	488.81	488.80	488.79	488.78	488.77
35.00	488.76	488.75	488.74	488.73	488.72
40.00	488.70	488.69	488.68	488.67	488.66
45.00	488.65	488.64	488.63	488.62	488.61
50.00	488.60	488.59	488.58	488.57	488.56
55.00	488.55	488.54	488.53	488.52	488.51
60.00	488.50	488.49	488.48	488.47	488.46
65.00	488.45	488.44	488.43	488.41	488.40
70.00	488.39	488.38	488.37	488.36	488.35
75.00	488.34	488.33	488.32	488.31	488.30
80.00	488.29	488.28	488.27	488.26	488.24
85.00	488.23	488.22	488.21	488.20	488.19
90.00	488.18	488.17	488.16	488.15	488.14
95.00	488.13	488.12	488.10	488.09	488.08
100.00	488.07	488.06	488.05	488.04	488.03
105.00	488.02	488.01	488.00	487.98	487.97
110.00	487.96	487.95	487.94	487.93	487.92
115.00	487.90	487.89	487.88	487.87	487.86
120.00	487.85	487.83	487.82	487.81	487.80
125.00	487.79	487.77	487.76	487.75	487.74
130.00	487.72	487.71	487.70	487.68	487.67
135.00	487.66	487.64	487.63	487.62	487.60
140.00	487.59	487.57	487.56	487.55	487.53
145.00	487.52	487.50	487.49	487.47	487.46
150.00	487.44	487.43	487.41	487.39	487.38
155.00	487.36	487.35	487.33	487.31	487.29
160.00	487.28	487.26	487.24	487.22	487.20
165.00	487.19	487.17	487.15	487.13	487.11
170.00	487.09	487.07	487.05	487.03	487.00
175.00	486.98	486.96	486.94	486.91	486.89
180.00	486.87	486.84	486.82	486.79	486.77
185.00	486.74	486.71	486.68	486.65	486.62
190.00	486.59	486.56	486.52	486.49	486.46
195.00	486.43	486.40	486.37	486.33	486.30
200.00	486.27	486.23	486.19	486.16	486.12
205.00	486.08	486.04	485.99	485.95	485.90
210.00	485.86	485.79	485.74	485.66	485.56

Type.... Time-Elev

Page 2.02

Name.... WEST OUT Tag: 15

Event: 15 yr

File.... H:\PONDPACK\9000PLUS\9203F-DATA\AS-BUILT PROPOSED PHASE.MODIFIED BASIN.04.14.2006

Storm... 15 Tag: 15

TIME vs. ELEVATION (ft)

Time		Output Time increment = 1.00 min
min		Time on left represents time for first value in each row.
----- -----		
215.00		485.55

TIME vs. ELEVATION (ft)

Output Time increment = 1.00 min
Time on left represents time for first value in each row.

Time min					
.00	485.55	486.06	486.35	486.60	486.82
5.00	487.03	487.23	487.41	487.59	487.75
10.00	487.89	488.01	488.13	488.24	488.35
15.00	488.45	488.55	488.65	488.74	488.83
20.00	488.92	489.00	489.07	489.12	489.16
25.00	489.19	489.21	489.22	489.21	489.20
30.00	489.19	489.18	489.17	489.16	489.16
35.00	489.15	489.14	489.13	489.12	489.11
40.00	489.10	489.09	489.08	489.07	489.06
45.00	489.05	489.04	489.03	489.02	489.01
50.00	489.00	488.99	488.98	488.97	488.96
55.00	488.95	488.94	488.93	488.92	488.91
60.00	488.90	488.89	488.88	488.87	488.86
65.00	488.85	488.84	488.83	488.82	488.81
70.00	488.80	488.79	488.78	488.77	488.76
75.00	488.75	488.74	488.73	488.72	488.71
80.00	488.70	488.69	488.68	488.67	488.66
85.00	488.65	488.64	488.63	488.62	488.60
90.00	488.59	488.58	488.57	488.56	488.55
95.00	488.54	488.53	488.52	488.51	488.50
100.00	488.49	488.48	488.47	488.46	488.45
105.00	488.44	488.43	488.42	488.41	488.40
110.00	488.39	488.38	488.36	488.35	488.34
115.00	488.33	488.32	488.31	488.30	488.29
120.00	488.28	488.27	488.26	488.25	488.24
125.00	488.23	488.22	488.20	488.19	488.18
130.00	488.17	488.16	488.15	488.14	488.13
135.00	488.12	488.11	488.10	488.09	488.07
140.00	488.06	488.05	488.04	488.03	488.02
145.00	488.01	488.00	487.99	487.98	487.97
150.00	487.95	487.94	487.93	487.92	487.91
155.00	487.90	487.88	487.87	487.86	487.85
160.00	487.84	487.83	487.81	487.80	487.79
165.00	487.78	487.76	487.75	487.74	487.73
170.00	487.71	487.70	487.69	487.67	487.66
175.00	487.65	487.63	487.62	487.61	487.59
180.00	487.58	487.56	487.55	487.53	487.52
185.00	487.50	487.49	487.48	487.46	487.45
190.00	487.43	487.41	487.40	487.38	487.37
195.00	487.35	487.33	487.32	487.30	487.28
200.00	487.26	487.25	487.23	487.21	487.19
205.00	487.17	487.15	487.13	487.11	487.09
210.00	487.07	487.05	487.03	487.01	486.99

TIME vs. ELEVATION (ft)

Output Time increment = 1.00 min
Time on left represents time for first value in each row.

Time min					
215.00	486.97	486.95	486.92	486.90	486.87
220.00	486.85	486.82	486.80	486.77	486.75
225.00	486.72	486.69	486.66	486.63	486.60
230.00	486.57	486.53	486.50	486.47	486.44
235.00	486.40	486.37	486.34	486.31	486.27
240.00	486.24	486.20	486.17	486.13	486.09
245.00	486.05	486.01	485.96	485.91	485.87
250.00	485.81	485.76	485.68	485.58	485.55

TIME vs. VOLUME (cu.ft)

Time min	Output Time increment = 1.00 min				
	Time on left represents time for first value in each row.				
.00	0	100	403	913	1616
5.00	2513	3641	4972	6533	8212
10.00	9873	11513	13138	14757	16382
15.00	18014	19598	21209	22803	24397
20.00	25994	27457	28676	29663	30388
25.00	30876	31125	31135	30905	30558
30.00	30212	29867	29520	29170	28821
35.00	28474	28130	27787	27447	27109
40.00	26773	26436	26091	25748	25407
45.00	25069	24734	24401	24074	23750
50.00	23425	23084	22746	22414	22086
55.00	21761	21441	21125	20813	20490
60.00	20159	19833	19511	19195	18882
65.00	18574	18270	17960	17637	17320
70.00	17007	16701	16398	16101	15808
75.00	15498	15187	14882	14582	14287
80.00	13998	13714	13418	13117	12820
85.00	12530	12246	11968	11695	11403
90.00	11113	10829	10553	10282	10018
95.00	9742	9461	9188	8921	8662
100.00	8409	8140	7872	7612	7359
105.00	7115	6866	6606	6356	6113
110.00	5880	5643	5395	5158	4930
115.00	4712	4478	4248	4030	3821
120.00	3606	3388	3183	2989	2784
125.00	2584	2398	2217	2026	1851
130.00	1690	1518	1372	1247	1113
135.00	995	891	781	682	597
140.00	507	428	363	291	235
145.00	182	136	100	65	41
150.00	20	7	1	0	

TIME vs. VOLUME (cu.ft)

Output Time increment = 1.00 min
Time on left represents time for first value in each row.

Time min	0	166	679	1529	2720
.00	0	166	679	1529	2720
5.00	4266	6181	8479	11127	13970
10.00	16784	19598	22403	25207	28002
15.00	30784	33561	36336	39088	41837
20.00	44588	47147	49286	51055	52407
25.00	53378	53960	54149	53943	53540
30.00	53142	52744	52348	51953	51562
35.00	51171	50778	50381	49984	49590
40.00	49199	48808	48420	48034	47650
45.00	47268	46880	46490	46102	45715
50.00	45331	44949	44570	44191	43814
55.00	43440	43057	42675	42295	41917
60.00	41542	41168	40796	40426	40058
65.00	39688	39313	38940	38569	38200
70.00	37832	37467	37104	36743	36384
75.00	36017	35651	35286	34924	34563
80.00	34206	33849	33495	33143	32789
85.00	32429	32073	31718	31365	31014
90.00	30666	30318	29974	29630	29278
95.00	28929	28582	28236	27894	27552
100.00	27214	26877	26542	26197	25855
105.00	25513	25174	24838	24504	24175
110.00	23850	23529	23190	22851	22517
115.00	22187	21861	21540	21222	20910
120.00	20594	20262	19934	19611	19293
125.00	18979	18669	18364	18061	17737
130.00	17418	17104	16795	16492	16193
135.00	15898	15596	15283	14977	14675
140.00	14379	14087	13802	13514	13210
145.00	12912	12620	12334	12054	11779
150.00	11494	11202	10917	10638	10366
155.00	10099	9831	9548	9272	9003
160.00	8742	8487	8225	7954	7692
165.00	7437	7190	6949	6686	6433
170.00	6188	5952	5722	5471	5231
175.00	5000	4779	4552	4319	4096
180.00	3885	3676	3454	3245	3048
185.00	2849	2644	2454	2277	2083
190.00	1904	1739	1569	1415	1284
195.00	1154	1030	922	815	711
200.00	622	534	451	383	311
205.00	251	200	149	112	74
210.00	49	25	12	2	0

Type.... Time vs. Volume

Name.... WEST OUT Tag: 15

Event: 15 yr

File.... H:\PONDPACK\9000PLUS\9203F-DATA\AS-BUILT PROPOSED PHASE.MODIFIED BASIN.04.14.2006

Storm... 15 Tag: 15

TIME vs. VOLUME (cu.ft)

Time	Output Time increment = 1.00 min
min	Time on left represents time for first value in each row.
----- -----	-----
215.00	0

TIME vs. VOLUME (cu.ft)

Time min	Output Time increment = 1.00 min				
	Time on left represents time for first value in each row.				
	0	220	882	1967	3509
5.00	5517	7991	10937	14366	18050
10.00	21672	25316	28951	32572	36182
15.00	39783	43375	46957	50529	54097
20.00	57656	60963	63778	66082	67899
25.00	69202	70016	70335	70155	69728
30.00	69303	68880	68458	68039	67620
35.00	67199	66773	66349	65926	65505
40.00	65086	64669	64254	63840	63428
45.00	63016	62596	62178	61763	61348
50.00	60937	60526	60117	59710	59306
55.00	58901	58488	58077	57669	57261
60.00	56855	56452	56050	55650	55253
65.00	54856	54450	54046	53644	53244
70.00	52846	52449	52055	51663	51272
75.00	50881	50483	50087	49692	49299
80.00	48908	48520	48133	47748	47365
85.00	46981	46590	46201	45814	45430
90.00	45047	44666	44288	43911	43536
95.00	43155	42773	42392	42014	41638
100.00	41264	40891	40521	40153	39785
105.00	39409	39035	38664	38293	37926
110.00	37561	37197	36835	36476	36111
115.00	35744	35380	35017	34656	34297
120.00	33940	33586	33234	32881	32522
125.00	32164	31809	31455	31104	30755
130.00	30407	30063	29720	29368	29019
135.00	28670	28325	27981	27640	27301
140.00	26964	26629	26286	25942	25600
145.00	25261	24923	24589	24259	23934
150.00	23611	23277	22937	22602	22271
155.00	21945	21622	21304	20990	20679
160.00	20346	20017	19693	19374	19059
165.00	18749	18442	18141	17820	17500
170.00	17184	16874	16569	16269	15974
175.00	15678	15363	15055	14752	14454
180.00	14161	13874	13592	13287	12988
185.00	12694	12407	12125	11849	11570
190.00	11277	10990	10709	10435	10167
195.00	9905	9620	9342	9072	8808
200.00	8552	8296	8023	7758	7502
205.00	7253	7011	6753	6497	6250
210.00	6011	5781	5535	5292	5058

TIME vs. VOLUME (cu.ft)

Time min	Output Time increment = 1.00 min				
	Time on left represents time for first value in each row.				
215.00	4835	4614	4377	4152	3938
220.00	3735	3510	3297	3097	2904
225.00	2695	2501	2321	2132	1948
230.00	1780	1613	1453	1316	1188
235.00	1061	949	845	736	644
240.00	559	471	399	330	265
245.00	215	160	120	82	54
250.00	30	15	4	0	0

POND VOLUME CALCULATIONS

Planimeter scale: 1.00 ft/in

Elevation (ft)	Planimeter (sq.in)	Area (sq.ft)	A1+A2+sq(A1*A2) (sq.ft)	Volume (cu.ft)	Volume Sum (cu.ft)
485.55	.000	0	0	0	0
488.00	30596.000	30596	30596	24987	24987
490.00	54535.000	54535	125979	83986	108973
492.00	65189.000	65189	179349	119566	228539
494.00	74425.000	74425	209268	139512	368051
495.00	78785.000	78785	229784	76595	444645

POND VOLUME EQUATIONS

* Incremental volume computed by the Conic Method for Reservoir Volumes.

$$\text{Volume} = (1/3) * (\text{EL2}-\text{EL1}) * (\text{Area1} + \text{Area2} + \text{sq.rt.}(\text{Area1}*\text{Area2}))$$

where: EL1, EL2 = Lower and upper elevations of the increment
 Area1,Area2 = Areas computed for EL1, EL2, respectively
 Volume = Incremental volume between EL1 and EL2

Name.... WEST

File.... H:\PONDPACK\9000PLUS\9203F-DATA\AS-BUILT PROPOSED PHASE.MODIFIED BASIN.04.14.2006

REQUESTED POND WS ELEVATIONS:

Min. Elev.= 485.55 ft
 Increment = .10 ft
 Max. Elev.= 495.00 ft

 OUTLET CONNECTIVITY

----> Forward Flow Only (UpStream to DnStream)
 <---- Reverse Flow Only (DnStream to UpStream)
 <----> Forward and Reverse Both Allowed

Structure	No.		Outfall	E1, ft	E2, ft
Weir-Rectangular	W0	---->	TW	485.550	486.550
Weir-Rectangular	W1	---->	TW	492.500	495.000
Stand Pipe	R0	---->	TW	492.660	495.000
Orifice-Area	O0	---->	TW	486.550	495.000
TW SETUP, DS Channel					

Type.... Outlet Input Data
Name.... WEST MODIFIED

File.... H:\PONDPACK\9000PLUS\9203F-DATA\AS-BUILT PROPOSED PHASE.MODIFIED BASIN.04.14.2006

OUTLET STRUCTURE INPUT DATA

Structure ID = W0
Structure Type = Weir-Rectangular

of Openings = 1
Crest Elev. = 485.55 ft
Weir Length = .83 ft
Weir Coeff. = 3.000000

Weir TW effects (Use adjustment equation)

Structure ID = W1
Structure Type = Weir-Rectangular

of Openings = 1
Crest Elev. = 492.50 ft
Weir Length = 35.00 ft
Weir Coeff. = 3.000000

Weir TW effects (Use adjustment equation)

OUTLET STRUCTURE INPUT DATA

Structure ID = R0
Structure Type = Stand Pipe

of Openings = 1
Invert Elev. = 492.66 ft
Diameter = 3.5000 ft
Orifice Area = 9.6211 sq.ft
Orifice Coeff. = .600
Weir Length = 11.00 ft
Weir Coeff. = 3.000
K, Reverse = 1.000
Mannings n = .0000
Kev,Charged Riser = .000
Weir Submergence = No
Orifice H to crest= Yes

Structure ID = O0
Structure Type = Orifice-Area

of Openings = 1
Invert Elev. = 485.55 ft
Area = .8300 sq.ft
Top of Orifice = 486.55 ft
Datum Elev. = 486.05 ft
Orifice Coeff. = .600

Structure ID = TW
Structure Type = TW SETUP, DS Channel

FREE OUTFALL CONDITIONS SPECIFIED

CONVERGENCE TOLERANCES...
Maximum Iterations= 40
Min. TW tolerance = .01 ft
Max. TW tolerance = .01 ft
Min. HW tolerance = .01 ft
Max. HW tolerance = .01 ft
Min. Q tolerance = .00 cfs
Max. Q tolerance = .00 cfs

***** COMPOSITE OUTFLOW SUMMARY *****

WS Elev, Total Q		Converge		Notes
Elev. ft	Q cfs	TW Elev ft	Error +/-ft	Contributing Structures
485.55	.00	Free	Outfall	W0
485.65	.08	Free	Outfall	W0
485.75	.22	Free	Outfall	W0
485.85	.41	Free	Outfall	W0
485.95	.63	Free	Outfall	W0
486.05	.88	Free	Outfall	W0
486.15	1.16	Free	Outfall	W0
486.25	1.46	Free	Outfall	W0
486.35	1.78	Free	Outfall	W0
486.45	2.13	Free	Outfall	W0
486.55	2.82	Free	Outfall	00
486.65	3.09	Free	Outfall	00
486.75	3.34	Free	Outfall	00
486.85	3.57	Free	Outfall	00
486.95	3.79	Free	Outfall	00
487.05	3.99	Free	Outfall	00
487.15	4.19	Free	Outfall	00
487.25	4.38	Free	Outfall	00
487.35	4.55	Free	Outfall	00
487.45	4.73	Free	Outfall	00
487.55	4.89	Free	Outfall	00
487.65	5.05	Free	Outfall	00
487.75	5.21	Free	Outfall	00
487.85	5.36	Free	Outfall	00
487.95	5.51	Free	Outfall	00
488.05	5.65	Free	Outfall	00
488.15	5.79	Free	Outfall	00
488.25	5.93	Free	Outfall	00
488.35	6.06	Free	Outfall	00
488.45	6.19	Free	Outfall	00
488.55	6.32	Free	Outfall	00
488.65	6.44	Free	Outfall	00
488.75	6.56	Free	Outfall	00
488.85	6.68	Free	Outfall	00
488.95	6.80	Free	Outfall	00
489.05	6.92	Free	Outfall	00
489.15	7.03	Free	Outfall	00
489.25	7.15	Free	Outfall	00

Name.... WEST MODIFIED

File.... H:\PONDPACK\9000PLUS\9203F-DATA\AS-BUILT PROPOSED PHASE.MODIFIED BASIN.04.14.2006

***** COMPOSITE OUTFLOW SUMMARY *****

WS Elev, Total Q		Converge		Notes
Elev. ft	Q cfs	TW Elev ft	Error +/-ft	Contributing Structures
489.35	7.26	Free	Outfall	00
489.45	7.37	Free	Outfall	00
489.55	7.47	Free	Outfall	00
489.65	7.58	Free	Outfall	00
489.75	7.68	Free	Outfall	00
489.85	7.79	Free	Outfall	00
489.95	7.89	Free	Outfall	00
490.05	7.99	Free	Outfall	00
490.15	8.09	Free	Outfall	00
490.25	8.19	Free	Outfall	00
490.35	8.28	Free	Outfall	00
490.45	8.38	Free	Outfall	00
490.55	8.47	Free	Outfall	00
490.65	8.57	Free	Outfall	00
490.75	8.66	Free	Outfall	00
490.85	8.75	Free	Outfall	00
490.95	8.84	Free	Outfall	00
491.05	8.93	Free	Outfall	00
491.15	9.02	Free	Outfall	00
491.25	9.11	Free	Outfall	00
491.35	9.20	Free	Outfall	00
491.45	9.28	Free	Outfall	00
491.55	9.37	Free	Outfall	00
491.65	9.45	Free	Outfall	00
491.75	9.54	Free	Outfall	00
491.85	9.62	Free	Outfall	00
491.95	9.70	Free	Outfall	00
492.05	9.79	Free	Outfall	00
492.15	9.87	Free	Outfall	00
492.25	9.95	Free	Outfall	00
492.35	10.03	Free	Outfall	00
492.45	10.11	Free	Outfall	00
492.50	10.15	Free	Outfall	W1 +00
492.55	11.36	Free	Outfall	W1 +00
492.65	16.36	Free	Outfall	W1 +00
492.66	16.99	Free	Outfall	W1 +R0 +00
492.75	24.36	Free	Outfall	W1 +R0 +00
492.85	34.89	Free	Outfall	W1 +R0 +00

***** COMPOSITE OUTFLOW SUMMARY *****

WS Elev, Total Q		Converge		Notes
Elev. ft	Q cfs	TW Elev ft	Error +/-ft	Contributing Structures
492.95	47.34	Free	Outfall	W1 +R0 +O0
493.05	61.43	Free	Outfall	W1 +R0 +O0
493.15	76.98	Free	Outfall	W1 +R0 +O0
493.25	93.87	Free	Outfall	W1 +R0 +O0
493.35	111.98	Free	Outfall	W1 +R0 +O0
493.45	131.25	Free	Outfall	W1 +R0 +O0
493.55	151.61	Free	Outfall	W1 +R0 +O0
493.65	172.99	Free	Outfall	W1 +R0 +O0
493.75	195.37	Free	Outfall	W1 +R0 +O0
493.85	218.67	Free	Outfall	W1 +R0 +O0
493.95	242.89	Free	Outfall	W1 +R0 +O0
494.05	267.98	Free	Outfall	W1 +R0 +O0
494.15	290.44	Free	Outfall	W1 +R0 +O0
494.25	312.91	Free	Outfall	W1 +R0 +O0
494.35	335.91	Free	Outfall	W1 +R0 +O0
494.45	359.45	Free	Outfall	W1 +R0 +O0
494.55	383.50	Free	Outfall	W1 +R0 +O0
494.65	408.05	Free	Outfall	W1 +R0 +O0
494.75	433.10	Free	Outfall	W1 +R0 +O0
494.85	458.63	Free	Outfall	W1 +R0 +O0
494.95	484.65	Free	Outfall	W1 +R0 +O0
495.00	497.84	Free	Outfall	W1 +R0 +O0

Name.... WEST MODIFIED

LEVEL POOL ROUTING DATA

HYG Dir = H:\PONDPACK\9000PLUS\9203F-DATA\
 Inflow HYG file = NONE STORED - WEST IN 2
 Outflow HYG file = NONE STORED - WEST OUT 2

Pond Node Data = WEST
 Pond Volume Data = WEST
 Pond Outlet Data = WEST MODIFIED

No Infiltration

INITIAL CONDITIONS

 Starting WS Elev = 485.55 ft
 Starting Volume = 0 cu.ft
 Starting Outflow = .00 cfs
 Starting Infiltr. = .00 cfs
 Starting Total Qout= .00 cfs
 Time Increment = 1.00 min

Elevation ft	Outflow cfs	Storage cu.ft	Area sq.ft	Infiltr. cfs	Q Total cfs	2S/t + O cfs
485.55	.00	0	0	.00	.00	.00
485.65	.08	2	51	.00	.08	.14
485.75	.22	14	204	.00	.22	.68
485.85	.41	46	459	.00	.41	1.94
485.95	.63	109	816	.00	.63	4.25
486.05	.88	212	1274	.00	.88	7.96
486.15	1.16	367	1835	.00	1.16	13.39
486.25	1.46	583	2498	.00	1.46	20.89
486.35	1.78	870	3262	.00	1.78	30.78
486.45	2.13	1239	4129	.00	2.13	43.41
486.55	2.82	1699	5097	.00	2.82	59.46
486.65	3.09	2261	6168	.00	3.09	78.48
486.75	3.34	2936	7340	.00	3.34	101.21
486.85	3.57	3733	8614	.00	3.57	128.00
486.95	3.79	4662	9990	.00	3.79	159.19
487.05	3.99	5734	11469	.00	3.99	195.14
487.15	4.19	6959	13049	.00	4.19	236.17
487.25	4.38	8348	14731	.00	4.38	282.63
487.35	4.55	9909	16515	.00	4.55	334.84
487.45	4.73	11654	18401	.00	4.73	393.18

Name.... WEST

File.... H:\PONDPACK\9000PLUS\9203F-DATA\AS-BUILT PROPOSED PHASE.MODIFIED BASIN.04.14.2006

LEVEL POOL ROUTING DATA

HYG Dir = H:\PONDPACK\9000PLUS\9203F-DATA\
 Inflow HYG file = NONE STORED - WEST IN 2
 Outflow HYG file = NONE STORED - WEST OUT 2

Pond Node Data = WEST
 Pond Volume Data = WEST
 Pond Outlet Data = WEST MODIFIED

No Infiltration

INITIAL CONDITIONS

 Starting WS Elev = 485.55 ft
 Starting Volume = 0 cu.ft
 Starting Outflow = .00 cfs
 Starting Infiltr. = .00 cfs
 Starting Total Qout= .00 cfs
 Time Increment = 1.00 min

Elevation ft	Outflow cfs	Storage cu.ft	Area sq.ft	Infilt. cfs	Q Total cfs	2S/t + O cfs
487.55	4.89	13592	20389	.00	4.89	457.97
487.65	5.05	15735	22479	.00	5.05	529.55
487.75	5.21	18092	24671	.00	5.21	608.27
487.85	5.36	20672	26964	.00	5.36	694.43
487.95	5.51	23488	29359	.00	5.51	788.42
488.05	5.65	26529	31111	.00	5.65	889.95
488.15	5.79	29692	32153	.00	5.79	995.53
488.25	5.93	32961	33213	.00	5.93	1104.61
488.35	6.06	36335	34289	.00	6.06	1217.22
488.45	6.19	39819	35383	.00	6.19	1333.47
488.55	6.32	43412	36494	.00	6.32	1453.40
488.65	6.44	47118	37623	.00	6.44	1577.05
488.75	6.56	50938	38768	.00	6.56	1704.49
488.85	6.68	54872	39930	.00	6.68	1835.74
488.95	6.80	58924	41110	.00	6.80	1970.93
489.05	6.92	63095	42307	.00	6.92	2110.08
489.15	7.03	67386	43521	.00	7.03	2253.24
489.25	7.15	71800	44753	.00	7.15	2400.48
489.35	7.26	76337	46001	.00	7.26	2551.81
489.45	7.37	81000	47267	.00	7.37	2707.37

Name.... WEST

File.... H:\PONDPACK\9000PLUS\9203F-DATA\AS-BUILT PROPOSED PHASE.MODIFIED BASIN.04.14.2006

LEVEL POOL ROUTING DATA

HYG Dir = H:\PONDPACK\9000PLUS\9203F-DATA\
 Inflow HYG file = NONE STORED - WEST IN 2
 Outflow HYG file = NONE STORED - WEST OUT 2

Pond Node Data = WEST
 Pond Volume Data = WEST
 Pond Outlet Data = WEST MODIFIED

No Infiltration

INITIAL CONDITIONS

 Starting WS Elev = 485.55 ft
 Starting Volume = 0 cu.ft
 Starting Outflow = .00 cfs
 Starting Infiltr. = .00 cfs
 Starting Total Qout= .00 cfs
 Time Increment = 1.00 min

Elevation ft	Outflow cfs	Storage cu.ft	Area sq.ft	Infiltr. cfs	Q Total cfs	2S/t + O cfs
489.55	7.47	85791	48550	.00	7.47	2867.18
489.65	7.58	90711	49850	.00	7.58	3031.28
489.75	7.68	95762	51167	.00	7.68	3199.76
489.85	7.79	100944	52501	.00	7.79	3372.59
489.95	7.89	106262	53853	.00	7.89	3549.95
490.05	7.99	111705	54790	.00	7.99	3731.49
490.15	8.09	117210	55301	.00	8.09	3915.09
490.25	8.19	122766	55815	.00	8.19	4100.39
490.35	8.28	128372	56331	.00	8.28	4287.35
490.45	8.38	134031	56849	.00	8.38	4476.09
490.55	8.47	139743	57370	.00	8.47	4666.56
490.65	8.57	145506	57893	.00	8.57	4858.77
490.75	8.66	151322	58419	.00	8.66	5052.72
490.85	8.75	157189	58947	.00	8.75	5248.38
490.95	8.84	163111	59477	.00	8.84	5445.85
491.05	8.93	169085	60010	.00	8.93	5645.10
491.15	9.02	175113	60545	.00	9.02	5846.12
491.25	9.11	181195	61082	.00	9.11	6048.93
491.35	9.20	187329	61622	.00	9.20	6253.48
491.45	9.28	193518	62164	.00	9.28	6459.89

Name.... WEST

File.... H:\PONDPACK\9000PLUS\9203F-DATA\AS-BUILT PROPOSED PHASE.MODIFIED BASIN.04.14.2006

LEVEL POOL ROUTING DATA

HYG Dir = H:\PONDPACK\9000PLUS\9203F-DATA\
 Inflow HYG file = NONE STORED - WEST IN 2
 Outflow HYG file = NONE STORED - WEST OUT 2

Pond Node Data = WEST
 Pond Volume Data = WEST
 Pond Outlet Data = WEST MODIFIED

No Infiltration

INITIAL CONDITIONS

 Starting WS Elev = 485.55 ft
 Starting Volume = 0 cu.ft
 Starting Outflow = .00 cfs
 Starting Infiltr. = .00 cfs
 Starting Total Qout= .00 cfs
 Time Increment = 1.00 min

Elevation ft	Outflow cfs	Storage cu.ft	Area sq.ft	Infiltr. cfs	Q Total cfs	2S/t + O cfs
491.55	9.37	199763	62709	.00	9.37	6668.10
491.65	9.45	206061	63256	.00	9.45	6878.14
491.75	9.54	212415	63805	.00	9.54	7090.01
491.85	9.62	218821	64357	.00	9.62	7303.64
491.95	9.70	225285	64911	.00	9.70	7519.18
492.05	9.79	231803	65412	.00	9.79	7736.53
492.15	9.87	238367	65860	.00	9.87	7955.41
492.25	9.95	244976	66310	.00	9.95	8175.79
492.35	10.03	251628	66761	.00	10.03	8397.60
492.45	10.11	258327	67214	.00	10.11	8620.98
492.50	10.15	261694	67441	.00	10.15	8733.27
492.55	11.36	265071	67668	.00	11.36	8847.05
492.65	16.36	271861	68124	.00	16.36	9078.38
492.66	16.99	272543	68169	.00	16.99	9101.75
492.75	24.36	278697	68581	.00	24.36	9314.23
492.85	34.89	285576	69039	.00	34.89	9554.07
492.95	47.34	292504	69500	.00	47.34	9797.44
493.05	61.43	299477	69962	.00	61.43	10043.98
493.15	76.98	306497	70425	.00	76.98	10293.52
493.25	93.87	313563	70890	.00	93.87	10545.94

Name.... WEST

File.... H:\PONDPACK\9000PLUS\9203F-DATA\AS-BUILT PROPOSED PHASE.MODIFIED BASIN.04.14.2006

LEVEL POOL ROUTING DATA

HYG Dir = H:\PONDPACK\9000PLUS\9203F-DATA\
 Inflow HYG file = NONE STORED - WEST IN 2
 Outflow HYG file = NONE STORED - WEST OUT 2

Pond Node Data = WEST
 Pond Volume Data = WEST
 Pond Outlet Data = WEST MODIFIED

No Infiltration

INITIAL CONDITIONS

 Starting WS Elev = 485.55 ft
 Starting Volume = 0 cu.ft
 Starting Outflow = .00 cfs
 Starting Infiltr. = .00 cfs
 Starting Total Qout= .00 cfs
 Time Increment = 1.00 min

Elevation ft	Outflow cfs	Storage cu.ft	Area sq.ft	Infiltr. cfs	Q Total cfs	2S/t + O cfs
493.35	111.98	320673	71356	.00	111.98	10801.07
493.45	131.25	327833	71824	.00	131.25	11058.99
493.55	151.61	335039	72294	.00	151.61	11319.56
493.65	172.99	342293	72765	.00	172.99	11582.72
493.75	195.37	349593	73237	.00	195.37	11848.44
493.85	218.67	356939	73711	.00	218.67	12116.60
493.95	242.89	364334	74187	.00	242.89	12387.33
494.05	267.98	371776	74640	.00	267.98	12660.49
494.15	290.44	379262	75071	.00	290.44	12932.49
494.25	312.91	386791	75503	.00	312.91	13205.93
494.35	335.91	394362	75937	.00	335.91	13481.27
494.45	359.45	401977	76372	.00	359.45	13758.67
494.55	383.50	409637	76808	.00	383.50	14038.03
494.65	408.05	417340	77245	.00	408.05	14319.36
494.75	433.10	425087	77683	.00	433.10	14602.64
494.85	458.63	432875	78123	.00	458.63	14887.78
494.95	484.65	440710	78564	.00	484.65	15174.95
495.00	497.84	444645	78785	.00	497.84	15319.31

Name.... WEST

File.... H:\PONDPACK\9000PLUS\9203F-DATA\AS-BUILT PROPOSED PHASE.MODIFIED BASIN.04.14.2006

SUMMARY FOR HYDROGRAPH ADDITION
at Node: WEST IN

HYG Directory: H:\PONDPACK\9000PLUS\9203F-DATA\

```

=====
Upstream Link ID  Upstream Node ID  HYG file      HYG ID      HYG tag
-----
WEST              WEST              2 W
=====

```

```

INFLOWS TO:  WEST              IN
-----
HYG file      HYG ID      HYG tag      Volume      Peak Time      Peak Flow
              cu.ft       min          cfs
-----
              2 W              38458        8.00        32.05

```

```

TOTAL FLOW INTO:  WEST              IN
-----
HYG file      HYG ID      HYG tag      Volume      Peak Time      Peak Flow
              cu.ft       min          cfs
-----
              WEST              IN  2              38458        8.00        32.05

```

TOTAL NODE INFLOW...

HYG file =

HYG ID = WEST IN

HYG Tag = 2

```

-----
Peak Discharge =      32.05 cfs
Time to Peak   =       8.00 min
HYG Volume     =     38458 cu.ft
-----

```

HYDROGRAPH ORDINATES (cfs)

Output Time increment = 1.00 min

Time | Time on left represents time for first value in each row.

Time min					
.00	.00	4.01	8.01	12.02	16.02
5.00	20.03	24.04	28.04	32.05	32.05
10.00	32.05	32.05	32.05	32.05	32.05
15.00	32.05	32.05	32.05	32.05	32.05
20.00	32.05	28.04	24.04	20.03	16.02
25.00	12.02	8.01	4.01	.00	

SUMMARY FOR HYDROGRAPH ADDITION
at Node: WEST IN

HYG Directory: H:\PONDPACK\9000PLUS\9203F-DATA\

Upstream Link ID	Upstream Node ID	HYG file	HYG ID	HYG tag
WEST	WEST		15 W	

INFLOWS TO: WEST IN

HYG file	HYG ID	HYG tag	Volume cu.ft	Peak Time min	Peak Flow cfs
	15 W		62544	8.00	52.12

TOTAL FLOW INTO: WEST IN

HYG file	HYG ID	HYG tag	Volume cu.ft	Peak Time min	Peak Flow cfs
	WEST	IN 15	62544	8.00	52.12

TOTAL NODE INFLOW...

HYG file =

HYG ID = WEST IN

HYG Tag = 15

 Peak Discharge = 52.12 cfs
 Time to Peak = 8.00 min
 HYG Volume = 62544 cu.ft

HYDROGRAPH ORDINATES (cfs)

Time | Output Time increment = 1.00 min
 min | Time on left represents time for first value in each row.

Time min	0.00	5.00	10.00	15.00	20.00	25.00
0.00	0.00	6.52	13.03	19.55	26.06	
5.00	32.58	39.09	45.61	52.12	52.12	
10.00	52.12	52.12	52.12	52.12	52.12	
15.00	52.12	52.12	52.12	52.12	52.12	
20.00	52.12	45.61	39.09	32.58	26.06	
25.00	19.55	13.03	6.52	0.00		

SUMMARY FOR HYDROGRAPH ADDITION
at Node: WEST IN

HYG Directory: H:\PONDPACK\9000PLUS\9203F-DATA\

```

=====
Upstream Link ID  Upstream Node ID  HYG file      HYG ID        HYG tag
-----
WEST              WEST                    25 W
=====

```

```

INFLOWS TO: WEST          IN
-----
HYG file      HYG ID        HYG tag      Volume      Peak Time     Peak Flow
              HYG ID        HYG tag      cu.ft       min           cfs
-----
              25 W          25 W          79325       8.00         66.10

```

```

TOTAL FLOW INTO: WEST          IN
-----
HYG file      HYG ID        HYG tag      Volume      Peak Time     Peak Flow
              HYG ID        HYG tag      cu.ft       min           cfs
-----
              WEST          IN  25          79325       8.00         66.10

```

TOTAL NODE INFLOW...

HYG file =

HYG ID = WEST IN

HYG Tag = 25

 Peak Discharge = 66.10 cfs
 Time to Peak = 8.00 min
 HYG Volume = 79325 cu.ft

HYDROGRAPH ORDINATES (cfs)

Time | Output Time increment = 1.00 min
 min | Time on left represents time for first value in each row.

Time min	0.00	5.00	10.00	15.00	20.00	25.00
0.00	.00	8.26	16.53	24.79	33.05	
5.00	41.32	49.58	57.84	66.10	66.10	
10.00	66.10	66.10	66.10	66.10	66.10	
15.00	66.10	66.10	66.10	66.10	66.10	
20.00	66.10	57.84	49.58	41.32	33.05	
25.00	24.79	16.53	8.26	.00		

LEVEL POOL ROUTING SUMMARY

HYG Dir = H:\PONDPACK\9000PLUS\9203F-DATA\
Inflow HYG file = NONE STORED - WEST IN 2
Outflow HYG file = NONE STORED - WEST OUT 2

Pond Node Data = WEST
Pond Volume Data = WEST
Pond Outlet Data = WEST MODIFIED

No Infiltration

INITIAL CONDITIONS

Starting WS Elev = 485.55 ft
Starting Volume = 0 cu.ft
Starting Outflow = .00 cfs
Starting Infiltr. = .00 cfs
Starting Total Qout = .00 cfs
Time Increment = 1.00 min

INFLOW/OUTFLOW HYDROGRAPH SUMMARY

=====
Peak Inflow = 32.05 cfs at 8.00 min
Peak Outflow = 5.85 cfs at 26.00 min

Peak Elevation = 488.19 ft
Peak Storage = 31135 cu.ft
=====

MASS BALANCE (cu.ft)

+ Initial Vol = 0
+ HYG Vol IN = 38458
- Infiltration = 0
- HYG Vol OUT = 38458
- Retained Vol = 0

Unrouted Vol = 0 cu.ft (.000% of Outflow Volume)

LEVEL POOL ROUTING SUMMARY

HYG Dir = H:\PONDPACK\9000PLUS\9203F-DATA\
 Inflow HYG file = NONE STORED - WEST IN 15
 Outflow HYG file = NONE STORED - WEST OUT 15

Pond Node Data = WEST
 Pond Volume Data = WEST
 Pond Outlet Data = WEST MODIFIED

No Infiltration

INITIAL CONDITIONS

 Starting WS Elev = 485.55 ft
 Starting Volume = 0 cu.ft
 Starting Outflow = .00 cfs
 Starting Infiltr. = .00 cfs
 Starting Total Qout= .00 cfs
 Time Increment = 1.00 min

INFLOW/OUTFLOW HYDROGRAPH SUMMARY

=====
 Peak Inflow = 52.12 cfs at 8.00 min
 Peak Outflow = 6.66 cfs at 27.00 min

 Peak Elevation = 488.83 ft
 Peak Storage = 54149 cu.ft
 =====

MASS BALANCE (cu.ft)

 + Initial Vol = 0
 + HYG Vol IN = 62544
 - Infiltration = 0
 - HYG Vol OUT = 62544
 - Retained Vol = 0

 Unrouted Vol = - cu.ft (.000% of Inflow Volume)

LEVEL POOL ROUTING SUMMARY

HYG Dir = H:\PONDPACK\9000PLUS\9203F-DATA\
Inflow HYG file = NONE STORED - WEST IN 25
Outflow HYG file = NONE STORED - WEST OUT 25

Pond Node Data = WEST
Pond Volume Data = WEST
Pond Outlet Data = WEST MODIFIED

No Infiltration

INITIAL CONDITIONS

Starting WS Elev = 485.55 ft
Starting Volume = 0 cu.ft
Starting Outflow = .00 cfs
Starting Infiltr. = .00 cfs
Starting Total Qout= .00 cfs
Time Increment = 1.00 min

INFLOW/OUTFLOW HYDROGRAPH SUMMARY

=====
Peak Inflow = 66.10 cfs at 8.00 min
Peak Outflow = 7.11 cfs at 27.00 min

Peak Elevation = 489.22 ft
Peak Storage = 70335 cu.ft
=====

MASS BALANCE (cu.ft)

+ Initial Vol = 0
+ HYG Vol IN = 79325
- Infiltration = 0
- HYG Vol OUT = 79325
- Retained Vol = 0

Unrouted Vol = - cu.ft (.000% of Inflow Volume)

----- W -----
WEST... 4.01, 6.01
WEST IN 2... 6.06, 6.08,
 6.10
WEST OUT 2... 2.01, 3.01,
 6.12, 2.02, 3.02, 6.13, 2.04,
 3.04, 6.14
WEST MODIFIED... 5.01, 5.04

STORMWATER DETENTION CALCULATIONS

PROPOSED DEVELOPMENT

EAST BASIN

Table of Contents

***** NETWORK SUMMARIES (DETAILED) *****

Watershed.....	2		
		Executive Summary (Nodes)	1.01
Watershed.....	15		
		Executive Summary (Nodes)	1.02
Watershed.....	25		
		Executive Summary (Nodes)	1.03

***** TIME VS.ELEV *****

EAST	OUT 2		
		Time-Elev	2.01
EAST	OUT 15		
		Time-Elev	2.02
EAST	OUT 25		
		Time-Elev	2.03

***** TIME VS.VOL *****

EAST	OUT 2		
		Time vs. Volume	3.01
EAST	OUT 15		
		Time vs. Volume	3.02
EAST	OUT 25		
		Time vs. Volume	3.03

***** POND VOLUMES *****

EAST.....	Vol: Planimeter	4.01
-----------	-----------------------	------

 Table of Contents

***** OUTLET STRUCTURES *****

EAST MODIFIED...	Outlet Input Data	5.01
	Composite Rating Curve	5.04

***** POND ROUTING *****

EAST.....	Pond E-V-Q Table	6.01
EAST	IN 2 Node: Pond Inflow Summary	6.06
EAST	IN 15 Node: Pond Inflow Summary	6.08
EAST	IN 25 Node: Pond Inflow Summary	6.10
EAST	OUT 2 Pond Routing Summary	6.12
EAST	OUT 15 Pond Routing Summary	6.13
EAST	OUT 25 Pond Routing Summary	6.14

Table of Contents (continued)

NETWORK SUMMARY -- NODES
 (Trun.= HYG Truncation: Blank=None; L=Left; R=Rt; LR=Left & Rt)

Node ID	Type	HYG Vol cu.ft	Trun.	Qpeak min	Qpeak cfs	Max WSEL ft
EAST	HYG	37512		12.00	31.26	
Outfall EAST	JCT	37512		20.00	30.96	
EAST	IN POND	37512		12.00	31.26	
EAST	OUT POND	37512		20.00	30.96	480.19
WEST	HYG	38458		8.00	32.05	
Outfall WEST	JCT	38458		26.00	5.85	
WEST	IN POND	38458		8.00	32.05	
WEST	OUT POND	38458		26.00	5.85	488.19

NETWORK SUMMARY -- NODES

(Trun.= HYG Truncation: Blank=None; L=Left; R=Rt; LR=Left & Rt)

Node ID	Type	HYG Vol cu.ft	Trun.	Qpeak min	Qpeak cfs	Max WSEL ft
EAST	HYG	60883		12.00	50.74	
Outfall EAST	JCT	60883		22.00	41.46	
EAST	IN POND	60883		12.00	50.74	
EAST	OUT POND	60883		22.00	41.46	481.38
WEST	HYG	62544		8.00	52.12	
Outfall WEST	JCT	62544		27.00	6.66	
WEST	IN POND	62544		8.00	52.12	
WEST	OUT POND	62544		27.00	6.66	488.83

NETWORK SUMMARY -- NODES

(Trun.= HYG Truncation: Blank=None; L=Left; R=Rt; LR=Left & Rt)

Node ID	Type	HYG Vol cu.ft	Trun.	Qpeak min	Qpeak cfs	Max WSEL ft
EAST	HYG	76738		12.00	63.95	
Outfall EAST	JCT	76738		23.00	46.92	
EAST	IN POND	76738		12.00	63.95	
EAST	OUT POND	76738		23.00	46.92	482.14
WEST	HYG	79325		8.00	66.10	
Outfall WEST	JCT	79325		27.00	7.11	
WEST	IN POND	79325		8.00	66.10	
WEST	OUT POND	79325		27.00	7.11	489.22

TIME vs. ELEVATION (ft)

Output Time increment = 1.00 min
Time on left represents time for first value in each row.

Time min					
.00	477.19	477.58	477.94	478.15	478.37
5.00	478.57	478.77	478.95	479.12	479.29
10.00	479.45	479.61	479.76	479.89	479.99
15.00	480.07	480.13	480.16	480.18	480.19
20.00	480.19	480.18	480.15	480.11	480.06
25.00	479.99	479.89	479.77	479.62	479.44
30.00	479.23	478.97	478.64	478.26	477.87
35.00	477.28	477.19			

TIME vs. ELEVATION (ft)

Output Time increment = 1.00 min

Time on left represents time for first value in each row.

Time min					
.00	477.19	477.73	478.11	478.42	478.70
5.00	478.97	479.22	479.45	479.67	479.89
10.00	480.10	480.28	480.45	480.62	480.75
15.00	480.87	480.98	481.08	481.16	481.24
20.00	481.31	481.36	481.38	481.37	481.34
25.00	481.27	481.18	481.06	480.91	480.72
30.00	480.48	480.20	479.87	479.53	479.18
35.00	478.81	478.44	478.05	477.56	477.19

TIME vs. ELEVATION (ft)

Time min	Output Time increment = 1.00 min				
	Time on left represents time for first value in each row.				

.00	477.19	477.82	478.21	478.56	478.89
5.00	479.18	479.46	479.73	479.98	480.20
10.00	480.41	480.63	480.85	481.06	481.24
15.00	481.40	481.54	481.67	481.79	481.89
20.00	481.99	482.07	482.12	482.14	482.13
25.00	482.10	482.03	481.95	481.83	481.68
30.00	481.50	481.27	481.00	480.68	480.34
35.00	479.99	479.66	479.31	478.95	478.58
40.00	478.19	477.78	477.19		

TIME vs. VOLUME (cu.ft)

Time min	Output Time increment = 1.00 min				
	Time on left represents time for first value in each row.				
.00	0	19	130	269	466
5.00	711	1002	1338	1719	2146
10.00	2611	3124	3678	4206	4643
15.00	5007	5275	5431	5515	5560
20.00	5585	5537	5389	5194	4946
25.00	4618	4198	3705	3158	2576
30.00	1976	1379	807	358	96
35.00	0	0			

TIME vs. VOLUME (cu.ft)

Time min	Output Time increment = 1.00 min				
	Time on left represents time for first value in each row.				
	0	50	239	519	900
.00	0	50	239	519	900
5.00	1374	1942	2601	3352	4195
10.00	5119	6039	6993	7980	8882
15.00	9719	10496	11221	11901	12542
20.00	13151	13601	13784	13707	13386
25.00	12839	12073	11102	9949	8629
30.00	7171	5607	4112	2856	1852
35.00	1083	538	194	15	0

TIME vs. VOLUME (cu.ft)

Time min	Output Time increment = 1.00 min				
	Time on left represents time for first value in each row.				

.00	0	79	316	698	1217
5.00	1864	2638	3540	4571	5625
10.00	6737	8045	9553	11108	12566
15.00	13947	15252	16502	17699	18845
20.00	19947	20851	21409	21634	21539
25.00	21135	20425	19429	18157	16625
30.00	14842	12832	10623	8402	6357
35.00	4647	3294	2198	1342	718
40.00	302	64	0		

POND VOLUME CALCULATIONS

Planimeter scale: 1.00 ft/in

Elevation (ft)	Planimeter (sq.in)	Area (sq.ft)	$A1+A2+\text{sq. rt.}(A1*A2)$ (sq.ft)	Volume (cu.ft)	Volume Sum (cu.ft)
477.19	.000	0	0	0	0
478.00	605.000	605	605	163	163
480.00	4509.000	4509	6766	4510	4674
482.00	11365.000	11365	23033	15355	20029
484.00	20067.000	20067	46534	31022	51051
485.00	22444.000	22444	63733	21244	72296
485.50	23656.000	23656	69142	11524	83819

POND VOLUME EQUATIONS

* Incremental volume computed by the Conic Method for Reservoir Volumes.

$$\text{Volume} = (1/3) * (\text{EL2}-\text{EL1}) * (\text{Areal} + \text{Area2} + \text{sq. rt.}(\text{Areal}*\text{Area2}))$$

where: EL1, EL2 = Lower and upper elevations of the increment
Areal, Area2 = Areas computed for EL1, EL2, respectively
Volume = Incremental volume between EL1 and EL2

REQUESTED POND WS ELEVATIONS:

Min. Elev.= 477.19 ft
 Increment = .10 ft
 Max. Elev.= 485.50 ft

 OUTLET CONNECTIVITY

---> Forward Flow Only (UpStream to DnStream)
 <--- Reverse Flow Only (DnStream to UpStream)
 <---> Forward and Reverse Both Allowed

Structure	No.	Outfall	E1, ft	E2, ft
Weir-Rectangular	W0	---> TW	477.190	480.190
Stand Pipe	R0	---> TW	482.240	485.500
Orifice-Area	O0	---> TW	480.190	485.500
TW SETUP, DS Channel				

Name.... EAST MODIFIED

File.... H:\PONDPACK\9000PLUS\9203F-DATA\AS-BUILT PROPOSED PHASE.MODIFIED BASIN.04.14.2006

OUTLET STRUCTURE INPUT DATA

Structure ID = W0
Structure Type = Weir-Rectangular

of Openings = 1
Crest Elev. = 477.19 ft
Weir Length = 1.75 ft
Weir Coeff. = 3.000000

Weir TW effects (Use adjustment equation)

Structure ID = R0
Structure Type = Stand Pipe

of Openings = 1
Invert Elev. = 482.24 ft
Diameter = 5.0000 ft
Orifice Area = 19.6350 sq.ft
Orifice Coeff. = .600
Weir Length = 15.71 ft
Weir Coeff. = 3.000
K, Reverse = 1.000
Mannings n = .0000
Kev,Charged Riser = .000
Weir Submergence = No
Orifice H to crest= Yes

Name.... EAST MODIFIED

File.... H:\PONDPACK\9000PLUS\9203F-DATA\AS-BUILT PROPOSED PHASE.MODIFIED BASIN.04.14.2006

OUTLET STRUCTURE INPUT DATA

Structure ID = 00
 Structure Type = Orifice-Area

 # of Openings = 1
 Invert Elev. = 477.19 ft
 Area = 5.2500 sq.ft
 Top of Orifice = 480.19 ft
 Datum Elev. = 478.69 ft
 Orifice Coeff. = .600

Structure ID = TW
 Structure Type = TW SETUP, DS Channel

FREE OUTFALL CONDITIONS SPECIFIED

CONVERGENCE TOLERANCES...
 Maximum Iterations= 40
 Min. TW tolerance = .01 ft
 Max. TW tolerance = .01 ft
 Min. HW tolerance = .01 ft
 Max. HW tolerance = .01 ft
 Min. Q tolerance = .00 cfs
 Max. Q tolerance = .00 cfs

***** COMPOSITE OUTFLOW SUMMARY *****

WS Elev, Total Q		Converge		Notes
Elev. ft	Q cfs	TW Elev ft	Error +/-ft	Contributing Structures
477.19	.00	Free	Outfall	W0
477.29	.17	Free	Outfall	W0
477.39	.47	Free	Outfall	W0
477.49	.86	Free	Outfall	W0
477.59	1.33	Free	Outfall	W0
477.69	1.86	Free	Outfall	W0
477.79	2.44	Free	Outfall	W0
477.89	3.07	Free	Outfall	W0
477.99	3.76	Free	Outfall	W0
478.09	4.48	Free	Outfall	W0
478.19	5.25	Free	Outfall	W0
478.29	6.06	Free	Outfall	W0
478.39	6.90	Free	Outfall	W0
478.49	7.78	Free	Outfall	W0
478.59	8.70	Free	Outfall	W0
478.69	9.64	Free	Outfall	W0
478.79	10.63	Free	Outfall	W0
478.89	11.64	Free	Outfall	W0
478.99	12.68	Free	Outfall	W0
479.09	13.75	Free	Outfall	W0
479.19	14.85	Free	Outfall	W0
479.29	15.98	Free	Outfall	W0
479.39	17.13	Free	Outfall	W0
479.49	18.31	Free	Outfall	W0
479.59	19.52	Free	Outfall	W0
479.69	20.75	Free	Outfall	W0
479.79	22.01	Free	Outfall	W0
479.89	23.29	Free	Outfall	W0
479.99	24.60	Free	Outfall	W0
480.09	25.93	Free	Outfall	W0
480.19	30.95	Free	Outfall	O0
480.29	31.96	Free	Outfall	O0
480.39	32.95	Free	Outfall	O0
480.49	33.90	Free	Outfall	O0
480.59	34.83	Free	Outfall	O0
480.69	35.73	Free	Outfall	O0
480.79	36.62	Free	Outfall	O0
480.89	37.48	Free	Outfall	O0

***** COMPOSITE OUTFLOW SUMMARY *****

WS Elev, Total Q		Converge		Notes
Elev. ft	Q cfs	TW Elev ft	Error +/-ft	Contributing Structures
480.99	38.32	Free	Outfall	00
481.09	39.15	Free	Outfall	00
481.19	39.95	Free	Outfall	00
481.29	40.74	Free	Outfall	00
481.39	41.52	Free	Outfall	00
481.49	42.28	Free	Outfall	00
481.59	43.03	Free	Outfall	00
481.69	43.77	Free	Outfall	00
481.79	44.49	Free	Outfall	00
481.89	45.20	Free	Outfall	00
481.99	45.90	Free	Outfall	00
482.09	46.59	Free	Outfall	00
482.19	47.27	Free	Outfall	00
482.24	47.61	Free	Outfall	R0 +00
482.29	48.47	Free	Outfall	R0 +00
482.39	51.34	Free	Outfall	R0 +00
482.49	55.15	Free	Outfall	R0 +00
482.59	59.66	Free	Outfall	R0 +00
482.69	64.76	Free	Outfall	R0 +00
482.79	70.39	Free	Outfall	R0 +00
482.89	76.48	Free	Outfall	R0 +00
482.99	83.01	Free	Outfall	R0 +00
483.09	89.93	Free	Outfall	R0 +00
483.19	97.24	Free	Outfall	R0 +00
483.29	104.90	Free	Outfall	R0 +00
483.39	112.90	Free	Outfall	R0 +00
483.49	121.22	Free	Outfall	R0 +00
483.59	129.85	Free	Outfall	R0 +00
483.69	138.78	Free	Outfall	R0 +00
483.79	148.00	Free	Outfall	R0 +00
483.89	157.50	Free	Outfall	R0 +00
483.99	167.27	Free	Outfall	R0 +00
484.09	177.30	Free	Outfall	R0 +00
484.19	187.58	Free	Outfall	R0 +00
484.29	195.11	Free	Outfall	R0 +00
484.39	198.90	Free	Outfall	R0 +00
484.49	202.61	Free	Outfall	R0 +00
484.59	206.25	Free	Outfall	R0 +00

***** COMPOSITE OUTFLOW SUMMARY *****

WS Elev, Total Q		Converge		Notes
Elev. ft	Q cfs	TW Elev ft	Error +/-ft	Contributing Structures
484.69	209.82	Free Outfall		R0 +00
484.79	213.32	Free Outfall		R0 +00
484.89	216.76	Free Outfall		R0 +00
484.99	220.14	Free Outfall		R0 +00
485.09	223.47	Free Outfall		R0 +00
485.19	226.74	Free Outfall		R0 +00
485.29	229.96	Free Outfall		R0 +00
485.39	233.13	Free Outfall		R0 +00
485.49	236.26	Free Outfall		R0 +00
485.50	236.57	Free Outfall		R0 +00

LEVEL POOL ROUTING DATA

HYG Dir = H:\PONDPACK\9000PLUS\9203F-DATA\
 Inflow HYG file = NONE STORED - EAST IN 2
 Outflow HYG file = NONE STORED - EAST OUT 2

Pond Node Data = EAST
 Pond Volume Data = EAST
 Pond Outlet Data = EAST MODIFIED

No Infiltration

INITIAL CONDITIONS

 Starting WS Elev = 477.19 ft
 Starting Volume = 0 cu.ft
 Starting Outflow = .00 cfs
 Starting Infiltr. = .00 cfs
 Starting Total Qout= .00 cfs
 Time Increment = 1.00 min

Elevation ft	Outflow cfs	Storage cu.ft	Area sq.ft	Infiltr. cfs	Q Total cfs	2S/t + O cfs
477.19	.00	0	0	.00	.00	.00
477.29	.17	0	9	.00	.17	.18
477.39	.47	2	37	.00	.47	.55
477.49	.86	8	83	.00	.86	1.14
477.59	1.33	20	148	.00	1.33	1.98
477.69	1.86	38	231	.00	1.86	3.14
477.79	2.44	66	332	.00	2.44	4.65
477.89	3.07	105	452	.00	3.07	6.59
477.99	3.76	157	590	.00	3.76	9.00
478.09	4.48	222	703	.00	4.48	11.89
478.19	5.25	298	820	.00	5.25	15.19
478.29	6.06	386	947	.00	6.06	18.94
478.39	6.90	488	1082	.00	6.90	23.16
478.49	7.78	603	1227	.00	7.78	27.89
478.59	8.70	733	1380	.00	8.70	33.14
478.69	9.64	880	1543	.00	9.64	38.96
478.79	10.63	1042	1714	.00	10.63	45.37
478.89	11.64	1223	1895	.00	11.64	52.39
478.99	12.68	1422	2085	.00	12.68	60.06
479.09	13.75	1640	2284	.00	13.75	68.41

Name.... EAST

File.... H:\PONDPACK\9000PLUS\9203F-DATA\AS-BUILT PROPOSED PHASE.MODIFIED BASIN.04.14.2006

LEVEL POOL ROUTING DATA

HYG Dir = H:\PONDPACK\9000PLUS\9203F-DATA\
 Inflow HYG file = NONE STORED - EAST IN 2
 Outflow HYG file = NONE STORED - EAST OUT 2

Pond Node Data = EAST
 Pond Volume Data = EAST
 Pond Outlet Data = EAST MODIFIED

No Infiltration

INITIAL CONDITIONS

 Starting WS Elev = 477.19 ft
 Starting Volume = 0 cu.ft
 Starting Outflow = .00 cfs
 Starting Infiltr. = .00 cfs
 Starting Total Qout= .00 cfs
 Time Increment = 1.00 min

Elevation ft	Outflow cfs	Storage cu.ft	Area sq.ft	Infiltr. cfs	Q Total cfs	2S/t + O cfs
479.19	14.85	1879	2492	.00	14.85	77.47
479.29	15.98	2139	2708	.00	15.98	87.26
479.39	17.13	2421	2934	.00	17.13	97.82
479.49	18.31	2726	3169	.00	18.31	109.17
479.59	19.52	3055	3414	.00	19.52	121.35
479.69	20.75	3409	3667	.00	20.75	134.38
479.79	22.01	3789	3929	.00	22.01	148.29
479.89	23.29	4195	4200	.00	23.29	163.12
479.99	24.60	4629	4480	.00	24.60	178.89
480.09	25.93	5090	4751	.00	25.93	195.61
480.19	30.95	5579	5026	.00	30.95	216.92
480.29	31.96	6096	5310	.00	31.96	235.16
480.39	32.95	6642	5602	.00	32.95	254.33
480.49	33.90	7216	5901	.00	33.90	274.45
480.59	34.83	7822	6208	.00	34.83	295.56
480.69	35.73	8458	6523	.00	35.73	317.68
480.79	36.62	9127	6845	.00	36.62	340.84
480.89	37.48	9828	7175	.00	37.48	365.07
480.99	38.32	10562	7513	.00	38.32	390.38
481.09	39.15	11331	7859	.00	39.15	416.83

Name.... EAST

File.... H:\PONDPACK\9000PLUS\9203F-DATA\AS-BUILT PROPOSED PHASE.MODIFIED BASIN.04.14.2006

LEVEL POOL ROUTING DATA

HYG Dir = H:\PONDPACK\9000PLUS\9203F-DATA\
 Inflow HYG file = NONE STORED - EAST IN 2
 Outflow HYG file = NONE STORED - EAST OUT 2

Pond Node Data = EAST
 Pond Volume Data = EAST
 Pond Outlet Data = EAST MODIFIED

No Infiltration

INITIAL CONDITIONS

 Starting WS Elev = 477.19 ft
 Starting Volume = 0 cu.ft
 Starting Outflow = .00 cfs
 Starting Infiltr. = .00 cfs
 Starting Total Qout= .00 cfs
 Time Increment = 1.00 min

Elevation ft	Outflow cfs	Storage cu.ft	Area sq.ft	Infiltr. cfs	Q Total cfs	2S/t + O cfs
481.19	39.95	12134	8213	.00	39.95	444.42
481.29	40.74	12974	8575	.00	40.74	473.19
481.39	41.52	13849	8944	.00	41.52	503.17
481.49	42.28	14762	9321	.00	42.28	534.36
481.59	43.03	15714	9706	.00	43.03	566.82
481.69	43.77	16704	10098	.00	43.77	600.56
481.79	44.49	17734	10499	.00	44.49	635.62
481.89	45.20	18804	10907	.00	45.20	672.00
481.99	45.90	19915	11323	.00	45.90	709.74
482.09	46.59	21067	11704	.00	46.59	748.82
482.19	47.27	22256	12086	.00	47.27	789.15
482.24	47.61	22865	12279	.00	47.61	809.79
482.29	48.47	23484	12475	.00	48.47	831.28
482.39	51.34	24752	12869	.00	51.34	876.40
482.49	55.15	26058	13270	.00	55.15	923.75
482.59	59.66	27406	13677	.00	59.66	973.17
482.69	64.76	28794	14090	.00	64.76	1024.56
482.79	70.39	30224	14509	.00	70.39	1077.85
482.89	76.48	31696	14934	.00	76.48	1133.01
482.99	83.01	33211	15365	.00	83.01	1190.02

Name.... EAST

File.... H:\PONDPACK\9000PLUS\9203F-DATA\AS-BUILT PROPOSED PHASE.MODIFIED BASIN.04.14.2006

LEVEL POOL ROUTING DATA

HYG Dir = H:\PONDPACK\9000PLUS\9203F-DATA\
 Inflow HYG file = NONE STORED - EAST IN 2
 Outflow HYG file = NONE STORED - EAST OUT 2

Pond Node Data = EAST
 Pond Volume Data = EAST
 Pond Outlet Data = EAST MODIFIED

No Infiltration

INITIAL CONDITIONS

 Starting WS Elev = 477.19 ft
 Starting Volume = 0 cu.ft
 Starting Outflow = .00 cfs
 Starting Infiltr. = .00 cfs
 Starting Total Qout= .00 cfs
 Time Increment = 1.00 min

Elevation ft	Outflow cfs	Storage cu.ft	Area sq.ft	Infiltr. cfs	Q Total cfs	2S/t + O cfs
483.09	89.93	34769	15803	.00	89.93	1248.90
483.19	97.24	36372	16247	.00	97.24	1309.62
483.29	104.90	38019	16697	.00	104.90	1372.19
483.39	112.90	39711	17153	.00	112.90	1436.60
483.49	121.22	41449	17615	.00	121.22	1502.85
483.59	129.85	43234	18083	.00	129.85	1570.98
483.69	138.78	45066	18557	.00	138.78	1640.98
483.79	148.00	46946	19038	.00	148.00	1712.86
483.89	157.50	48874	19525	.00	157.50	1786.63
483.99	167.27	50851	20017	.00	167.27	1862.28
484.09	177.30	52867	20275	.00	177.30	1939.51
484.19	187.58	54906	20508	.00	187.58	2017.77
484.29	195.11	56969	20743	.00	195.11	2094.05
484.39	198.90	59055	20978	.00	198.90	2167.39
484.49	202.61	61164	21215	.00	202.61	2241.40
484.59	206.25	63297	21453	.00	206.25	2316.16
484.69	209.82	65455	21693	.00	209.82	2391.64
484.79	213.32	67636	21934	.00	213.32	2467.86
484.89	216.76	69842	22176	.00	216.76	2544.82
484.99	220.14	72071	22420	.00	220.14	2622.51

Name.... EAST

File.... H:\PONDPACK\9000PLUS\9203F-DATA\AS-BUILT PROPOSED PHASE.MODIFIED BASIN.04.14.2006

LEVEL POOL ROUTING DATA

HYG Dir = H:\PONDPACK\9000PLUS\9203F-DATA\
 Inflow HYG file = NONE STORED - EAST IN 2
 Outflow HYG file = NONE STORED - EAST OUT 2

Pond Node Data = EAST
 Pond Volume Data = EAST
 Pond Outlet Data = EAST MODIFIED

No Infiltration

INITIAL CONDITIONS

 Starting WS Elev = 477.19 ft
 Starting Volume = 0 cu.ft
 Starting Outflow = .00 cfs
 Starting Infiltr. = .00 cfs
 Starting Total Qout= .00 cfs
 Time Increment = 1.00 min

Elevation ft	Outflow cfs	Storage cu.ft	Area sq.ft	Infiltr. cfs	Q Total cfs	2S/t + O cfs
485.09	223.47	74325	22660	.00	223.47	2700.97
485.19	226.74	76603	22901	.00	226.74	2780.18
485.29	229.96	78906	23143	.00	229.96	2860.15
485.39	233.13	81232	23387	.00	233.13	2940.88
485.49	236.26	83583	23631	.00	236.26	3022.35
485.50	236.57	83819	23656	.00	236.57	3030.55

Name.... EAST

File.... H:\PONDPACK\9000PLUS\9203F-DATA\AS-BUILT PROPOSED PHASE.MODIFIED BASIN.04.14.2006

SUMMARY FOR HYDROGRAPH ADDITION
at Node: EAST IN

HYG Directory: H:\PONDPACK\9000PLUS\9203F-DATA\

```

=====
Upstream Link ID  Upstream Node ID  HYG file  HYG ID  HYG tag
-----
EAST              EAST              2 E
=====

```

```

INFLOWS TO:  EAST              IN
-----
HYG file      HYG ID      HYG tag      Volume      Peak Time      Peak Flow
              HYG ID      HYG tag      cu.ft       min           cfs
-----
              2 E              37512       12.00       31.26

```

```

TOTAL FLOW INTO:  EAST              IN
-----
HYG file      HYG ID      HYG tag      Volume      Peak Time      Peak Flow
              HYG ID      HYG tag      cu.ft       min           cfs
-----
EAST          IN  2          37512       12.00       31.26

```

TOTAL NODE INFLOW...

HYG file =
 HYG ID = EAST IN
 HYG Tag = 2

 Peak Discharge = 31.26 cfs
 Time to Peak = 12.00 min
 HYG Volume = 37512 cu.ft

HYDROGRAPH ORDINATES (cfs)

Time | Output Time increment = 1.00 min
 min | Time on left represents time for first value in each row.

Time min	0.00	5.00	10.00	15.00	20.00	25.00	30.00
0.00	2.61	5.21	7.82	10.42			
5.00	13.03	15.63	18.24	20.84	23.45		
10.00	26.05	28.66	31.26	31.26	31.26	31.26	
15.00	31.26	31.26	31.26	31.26	31.26	31.26	
20.00	31.26	28.66	26.05	23.45	20.84		
25.00	18.24	15.63	13.03	10.42	7.82		
30.00	5.21	2.61	.00				

SUMMARY FOR HYDROGRAPH ADDITION
at Node: EAST IN

HYG Directory: H:\PONDPACK\9000PLUS\9203F-DATA\

```

=====
Upstream Link ID  Upstream Node ID  HYG file  HYG ID  HYG tag
-----
EAST              EAST              15 E
=====
    
```

```

INFLOWS TO:  EAST          IN
-----
HYG file      HYG ID      HYG tag      Volume      Peak Time      Peak Flow
              HYG ID      HYG tag      cu.ft        min            cfs
-----
              15 E              60883        12.00        50.74
    
```

```

TOTAL FLOW INTO:  EAST          IN
-----
HYG file      HYG ID      HYG tag      Volume      Peak Time      Peak Flow
              HYG ID      HYG tag      cu.ft        min            cfs
-----
              EAST          IN  15          60883        12.00        50.74
    
```

TOTAL NODE INFLOW...

HYG file =
 HYG ID = EAST IN
 HYG Tag = 15

 Peak Discharge = 50.74 cfs
 Time to Peak = 12.00 min
 HYG Volume = 60883 cu.ft

HYDROGRAPH ORDINATES (cfs)

Time | Output Time increment = 1.00 min
 min | Time on left represents time for first value in each row.

Time min	4.23	8.46	12.68	16.91
.00	4.23	8.46	12.68	16.91
5.00	21.14	25.37	29.60	33.82
10.00	42.28	46.51	50.74	50.74
15.00	50.74	50.74	50.74	50.74
20.00	50.74	46.51	42.28	38.05
25.00	29.60	25.37	21.14	16.91
30.00	8.46	4.23	.00	

SUMMARY FOR HYDROGRAPH ADDITION
at Node: EAST IN

HYG Directory: H:\PONDPACK\9000PLUS\9203F-DATA\

```

=====
Upstream Link ID  Upstream Node ID  HYG file      HYG ID      HYG tag
-----
EAST              EAST              25 E
=====
    
```

```

INFLOWS TO:  EAST          IN
-----
HYG file      HYG ID      HYG tag      Volume      Peak Time      Peak Flow
              cu.ft       min          cfs
-----
              25 E              76738        12.00        63.95
    
```

```

TOTAL FLOW INTO:  EAST          IN
-----
HYG file      HYG ID      HYG tag      Volume      Peak Time      Peak Flow
              cu.ft       min          cfs
-----
              EAST          IN  25          76738        12.00        63.95
    
```

TOTAL NODE INFLOW...

HYG file =
HYG ID = EAST IN
HYG Tag = 25

Peak Discharge = 63.95 cfs
Time to Peak = 12.00 min
HYG Volume = 76738 cu.ft

HYDROGRAPH ORDINATES (cfs)

Output Time increment = 1.00 min
Time on left represents time for first value in each row.

Time min					
.00	.00	5.33	10.66	15.99	21.32
5.00	26.65	31.97	37.30	42.63	47.96
10.00	53.29	58.62	63.95	63.95	63.95
15.00	63.95	63.95	63.95	63.95	63.95
20.00	63.95	58.62	53.29	47.96	42.63
25.00	37.30	31.97	26.65	21.32	15.99
30.00	10.66	5.33	.00		

LEVEL POOL ROUTING SUMMARY

HYG Dir = H:\PONDPACK\9000PLUS\9203F-DATA\
 Inflow HYG file = NONE STORED - EAST IN 2
 Outflow HYG file = NONE STORED - EAST OUT 2

Pond Node Data = EAST
 Pond Volume Data = EAST
 Pond Outlet Data = EAST MODIFIED

No Infiltration

INITIAL CONDITIONS

 Starting WS Elev = 477.19 ft
 Starting Volume = 0 cu.ft
 Starting Outflow = .00 cfs
 Starting Infiltr. = .00 cfs
 Starting Total Qout = .00 cfs
 Time Increment = 1.00 min

INFLOW/OUTFLOW HYDROGRAPH SUMMARY

=====
 Peak Inflow = 31.26 cfs at 12.00 min
 Peak Outflow = 30.96 cfs at 20.00 min

Peak Elevation = 480.19 ft
 Peak Storage = 5585 cu.ft
 =====

MASS BALANCE (cu.ft)

 + Initial Vol = 0
 + HYG Vol IN = 37512
 - Infiltration = 0
 - HYG Vol OUT = 37512
 - Retained Vol = 0

 Unrouted Vol = 0 cu.ft (.000% of Outflow Volume)

LEVEL POOL ROUTING SUMMARY

HYG Dir = H:\PONDPACK\9000PLUS\9203F-DATA\
Inflow HYG file = NONE STORED - EAST IN 15
Outflow HYG file = NONE STORED - EAST OUT 15

Pond Node Data = EAST
Pond Volume Data = EAST
Pond Outlet Data = EAST MODIFIED

No Infiltration

INITIAL CONDITIONS

Starting WS Elev = 477.19 ft
Starting Volume = 0 cu.ft
Starting Outflow = .00 cfs
Starting Infiltr. = .00 cfs
Starting Total Qout= .00 cfs
Time Increment = 1.00 min

INFLOW/OUTFLOW HYDROGRAPH SUMMARY

=====
Peak Inflow = 50.74 cfs at 12.00 min
Peak Outflow = 41.46 cfs at 22.00 min

Peak Elevation = 481.38 ft
Peak Storage = 13784 cu.ft
=====

MASS BALANCE (cu.ft)

+ Initial Vol = 0
+ HYG Vol IN = 60883
- Infiltration = 0
- HYG Vol OUT = 60883
- Retained Vol = 0

Unrouted Vol = 0 cu.ft (.000% of Outflow Volume)

LEVEL POOL ROUTING SUMMARY

HYG Dir = H:\PONDPACK\9000PLUS\9203F-DATA\
Inflow HYG file = NONE STORED - EAST IN 25
Outflow HYG file = NONE STORED - EAST OUT 25

Pond Node Data = EAST
Pond Volume Data = EAST
Pond Outlet Data = EAST MODIFIED

No Infiltration

INITIAL CONDITIONS

Starting WS Elev = 477.19 ft
Starting Volume = 0 cu.ft
Starting Outflow = .00 cfs
Starting Infiltr. = .00 cfs
Starting Total Qout = .00 cfs
Time Increment = 1.00 min

INFLOW/OUTFLOW HYDROGRAPH SUMMARY

=====
Peak Inflow = 63.95 cfs at 12.00 min
Peak Outflow = 46.92 cfs at 23.00 min

Peak Elevation = 482.14 ft
Peak Storage = 21634 cu.ft
=====

MASS BALANCE (cu.ft)

+ Initial Vol = 0
+ HYG Vol IN = 76738
- Infiltration = 0
- HYG Vol OUT = 76738
- Retained Vol = 0

Unrouted Vol = 0 cu.ft (.000% of Outflow Volume)

----- E -----

EAST... 4.01, 6.01

EAST IN 2... 6.06, 6.08,
6.10

EAST OUT 2... 2.01, 3.01,
6.12, 2.02, 3.02, 6.13, 2.03,
3.03, 6.14

EAST MODIFIED... 5.01, 5.04, 1.01,
1.02, 1.03

STORMWATER DETENTION CALCULATIONS

PROPOSED DEVELOPMENT

WEST BASIN

100 YR. LOW FLOW BLOCKED

Table of Contents

***** NETWORK SUMMARIES (DETAILED) *****

Watershed..... 100
Executive Summary (Nodes) 1.01

***** TIME VS.ELEV *****

WEST OUT 100
Time-Elev 2.01

***** TIME VS.VOL *****

WEST OUT 100
Time vs. Volume 3.01

***** POND VOLUMES *****

WEST..... Vol: Planimeter 4.01

***** OUTLET STRUCTURES *****

WEST MOD. LFB... Outlet Input Data 5.01
Composite Rating Curve 5.03

***** POND ROUTING *****

WEST..... Pond E-V-Q Table 6.01

Table of Contents

WEST	IN 100	
	Node: Pond Inflow Summary	6.06
WEST	OUT 100	
	Pond Routing Summary	6.08

Table of Contents (continued)

NETWORK SUMMARY -- NODES
 (Trun.= HYG Truncation: Blank=None; L=Left; R=Rt; LR=Left & Rt)

Node ID	Type	HYG Vol cu.ft	Trun.	Qpeak min	Qpeak cfs	Max WSEL ft
-----	-----	-----	-----	-----	-----	-----
Outfall EAST	HYG	96120		12.00	80.10	
EAST	JCT	96117		20.00	77.02	
EAST	IN POND	96120		12.00	80.10	
EAST	OUT POND	96117		20.00	77.02	483.63
WEST	HYG	98640		8.00	82.20	
Outfall WEST	JCT	109481	L	21.00	70.84	
WEST	IN POND	98640		8.00	82.20	
WEST	OUT POND	109481	L	21.00	70.84	493.18

Name.... Watershed

Event: 100 yr

File.... H:\PONDPACK\9000PLUS\9203F-DATA\AS-BUILT PROPOSED PHASE.MODIFIED BASIN.LFB.04.17.

Storm... 100 Tag: 100

TIME vs. ELEVATION (ft)

Time min	Output Time increment = 1.00 min				
	Time on left represents time for first value in each row.				
.00	492.66	492.66	492.67	492.68	492.71
5.00	492.74	492.77	492.81	492.86	492.91
10.00	492.95	492.99	493.02	493.05	493.07
15.00	493.10	493.11	493.13	493.15	493.16
20.00	493.17	493.18	493.17	493.16	493.15
25.00	493.12	493.09	493.06	493.02	492.98
30.00	492.95	492.92	492.89	492.87	492.85
35.00	492.83	492.81	492.79	492.78	492.76
40.00	492.75	492.74	492.73	492.72	492.71
45.00	492.70	492.69	492.68	492.67	492.67
50.00	492.66	492.66	492.65	492.64	492.64
55.00	492.63	492.63	492.63	492.62	492.62
60.00	492.61	492.61	492.61	492.60	492.60
65.00	492.60	492.59	492.59	492.59	492.59
70.00	492.58	492.58	492.58	492.58	492.57
75.00	492.57	492.57	492.57	492.57	492.56
80.00	492.56	492.56	492.56	492.56	492.56
85.00	492.56	492.55	492.55	492.55	492.55
90.00	492.55	492.55	492.55	492.55	492.55
95.00	492.54	492.54	492.54	492.54	492.54
100.00	492.54	492.54	492.54	492.54	492.54
105.00	492.54	492.54	492.53	492.53	492.53
110.00	492.53	492.53	492.53	492.53	492.53
115.00	492.53	492.53	492.53	492.53	492.53
120.00	492.53	492.53	492.53	492.53	492.52
125.00	492.52	492.52	492.52	492.52	492.52
130.00	492.52	492.52	492.52	492.52	492.52
135.00	492.52	492.52	492.52	492.52	492.52
140.00	492.52	492.52	492.52	492.52	492.52
145.00	492.52	492.52	492.52	492.51	492.51
150.00	492.51	492.51	492.51	492.51	492.51
155.00	492.51	492.51	492.51	492.51	492.51
160.00	492.51	492.51	492.51	492.51	492.51
165.00	492.51	492.51	492.51	492.51	492.51
170.00	492.51	492.51	492.51	492.51	492.51
175.00	492.51	492.51	492.51	492.51	492.51
180.00	492.51	492.51	492.51	492.51	492.51
185.00	492.51	492.51	492.51	492.51	492.51
190.00	492.51	492.51	492.51	492.51	492.51
195.00	492.51	492.51	492.51	492.51	492.51
200.00	492.51	492.50	492.50	492.50	492.50
205.00	492.50	492.50	492.50	492.50	492.50
210.00	492.50	492.50	492.50	492.50	492.50

TIME vs. ELEVATION (ft)

Time min	Output Time increment = 1.00 min				
	Time on left represents time for first value in each row.				
215.00	492.50	492.50	492.50	492.50	492.50
220.00	492.50	492.50	492.50	492.50	492.50
225.00	492.50	492.50	492.50	492.50	492.50
230.00	492.50	492.50	492.50	492.50	492.50
235.00	492.50	492.50	492.50	492.50	492.50
240.00	492.50	492.50	492.50	492.50	492.50
245.00	492.50	492.50	492.50	492.50	492.50
250.00	492.50	492.50	492.50	492.50	492.50
255.00	492.50	492.50	492.50	492.50	492.50
260.00	492.50	492.50	492.50	492.50	492.50
265.00	492.50	492.50	492.50	492.50	492.50
270.00	492.50	492.50	492.50	492.50	492.50
275.00	492.50	492.50	492.50	492.50	492.50
280.00	492.50	492.50	492.50	492.50	492.50
285.00	492.50	492.50	492.50	492.50	492.50
290.00	492.50	492.50	492.50	492.50	492.50
295.00	492.50	492.50	492.50	492.50	492.50
300.00	492.50	492.50	492.50	492.50	492.50
305.00	492.50	492.50	492.50	492.50	492.50
310.00	492.50	492.50	492.50	492.50	492.50
315.00	492.50	492.50	492.50	492.50	492.50
320.00	492.50	492.50	492.50	492.50	492.50
325.00	492.50	492.50	492.50	492.50	492.50
330.00	492.50	492.50	492.50	492.50	492.50
335.00	492.50	492.50	492.50	492.50	492.50
340.00	492.50	492.50	492.50	492.50	492.50
345.00	492.50	492.50	492.50	492.50	492.50
350.00	492.50	492.50	492.50	492.50	492.50
355.00	492.50	492.50	492.50	492.50	492.50
360.00	492.50	492.50	492.50	492.50	492.50
365.00	492.50	492.50	492.50	492.50	492.50
370.00	492.50	492.50	492.50	492.50	492.50
375.00	492.50	492.50	492.50	492.50	492.50

TIME vs. VOLUME (cu.ft)

Output Time increment = 1.00 min

Time on left represents time for first value in each row.

Time min					
.00	272543	272452	272959	274028	275619
5.00	277699	280213	283108	286337	289543
10.00	292431	295001	297284	299310	301090
15.00	302652	304022	305223	306275	307191
20.00	307985	308385	308159	307389	306142
25.00	304474	302436	300077	297414	294771
30.00	292431	290336	288456	286771	285256
35.00	283877	282618	281472	280427	279474
40.00	278603	277795	277043	276343	275692
45.00	275087	274524	273999	273509	273055
50.00	272631	272233	271857	271497	271155
55.00	270826	270511	270210	269921	269645
60.00	269380	269127	268886	268654	268433
65.00	268219	268016	267822	267635	267457
70.00	267287	267124	266967	266818	266675
75.00	266536	266406	266280	266160	266044
80.00	265935	265829	265728	265631	265538
85.00	265449	265365	265284	265205	265131
90.00	265061	264991	264923	264856	264790
95.00	264726	264665	264603	264543	264483
100.00	264425	264369	264314	264260	264206
105.00	264155	264105	264054	264006	263959
110.00	263911	263866	263821	263777	263734
115.00	263691	263649	263610	263571	263532
120.00	263493	263456	263421	263383	263350
125.00	263315	263282	263249	263216	263186
130.00	263155	263124	263095	263066	263037
135.00	263010	262984	262957	262930	262905
140.00	262881	262856	262831	262808	262786
145.00	262763	262740	262718	262697	262677
150.00	262656	262637	262617	262598	262580
155.00	262561	262543	262526	262508	262491
160.00	262475	262458	262444	262427	262413
165.00	262398	262384	262370	262355	262341
170.00	262328	262316	262302	262289	262277
175.00	262265	262254	262242	262232	262219
180.00	262209	262199	262188	262178	262168
185.00	262158	262149	262139	262131	262120
190.00	262112	262104	262096	262088	262079
195.00	262071	262063	262055	262048	262040
200.00	262034	262026	262020	262013	262007
205.00	261999	261993	261987	261980	261976
210.00	261970	261964	261958	261954	261948

TIME vs. VOLUME (cu.ft)

Time min	Output Time increment = 1.00 min				
	Time on left represents time for first value in each row.				
215.00	261941	261937	261933	261927	261923
220.00	261919	261913	261908	261904	261900
225.00	261896	261892	261888	261884	261880
230.00	261875	261871	261867	261865	261861
235.00	261857	261855	261851	261849	261845
240.00	261843	261838	261836	261832	261830
245.00	261826	261824	261822	261820	261816
250.00	261814	261812	261810	261808	261803
255.00	261801	261799	261797	261795	261793
260.00	261791	261789	261787	261785	261783
265.00	261781	261781	261779	261777	261775
270.00	261773	261771	261771	261768	261766
275.00	261764	261764	261762	261760	261760
280.00	261758	261756	261756	261754	261754
285.00	261752	261750	261750	261748	261748
290.00	261746	261746	261744	261744	261742
295.00	261742	261740	261740	261738	261738
300.00	261736	261736	261736	261733	261733
305.00	261731	261731	261731	261729	261729
310.00	261729	261727	261727	261727	261725
315.00	261725	261725	261723	261723	261723
320.00	261721	261721	261721	261721	261719
325.00	261719	261719	261719	261717	261717
330.00	261717	261717	261715	261715	261715
335.00	261715	261715	261713	261713	261713
340.00	261713	261713	261713	261711	261711
345.00	261711	261711	261711	261711	261709
350.00	261709	261709	261709	261709	261709
355.00	261707	261707	261707	261707	261707
360.00	261707	261707	261707	261705	261705
365.00	261705	261705	261705	261705	261705
370.00	261705	261705	261705	261703	261703
375.00	261703	261703	261703		

POND VOLUME CALCULATIONS

Planimeter scale: 1.00 ft/in

Elevation (ft)	Planimeter (sq.in)	Area (sq.ft)	A1+A2+sqr(A1*A2) (sq.ft)	Volume (cu.ft)	Volume Sum (cu.ft)
485.55	.000	0	0	0	0
488.00	30596.000	30596	30596	24987	24987
490.00	54535.000	54535	125979	83986	108973
492.00	65189.000	65189	179349	119566	228539
494.00	74425.000	74425	209268	139512	368051
495.00	78785.000	78785	229784	76595	444645

POND VOLUME EQUATIONS

* Incremental volume computed by the Conic Method for Reservoir Volumes.

$$\text{Volume} = (1/3) * (\text{EL2}-\text{EL1}) * (\text{Area1} + \text{Area2} + \text{sq.rt.}(\text{Area1}*\text{Area2}))$$

where: EL1, EL2 = Lower and upper elevations of the increment
 Area1,Area2 = Areas computed for EL1, EL2, respectively
 Volume = Incremental volume between EL1 and EL2

REQUESTED POND WS ELEVATIONS:

Min. Elev.= 485.55 ft
 Increment = .10 ft
 Max. Elev.= 495.00 ft

 OUTLET CONNECTIVITY

---> Forward Flow Only (UpStream to DnStream)
 <--- Reverse Flow Only (DnStream to UpStream)
 <---> Forward and Reverse Both Allowed

Structure	No.	Outfall	E1, ft	E2, ft
Stand Pipe	R0	---> TW	492.660	495.000
Weir-Rectangular	W1	---> TW	492.500	495.000
TW SETUP, DS Channel				

OUTLET STRUCTURE INPUT DATA

Structure ID = R0
Structure Type = Stand Pipe

of Openings = 1
Invert Elev. = 492.66 ft
Diameter = 3.5000 ft
Orifice Area = 9.6211 sq.ft
Orifice Coeff. = .600
Weir Length = 11.00 ft
Weir Coeff. = 3.000
K, Reverse = 1.000
Mannings n = .0000
Kev,Charged Riser = .000
Weir Submergence = No
Orifice H to crest= Yes

Structure ID = W1
Structure Type = Weir-Rectangular

of Openings = 1
Crest Elev. = 492.50 ft
Weir Length = 35.00 ft
Weir Coeff. = 3.000000

Weir TW effects (Use adjustment equation)

Structure ID = TW
Structure Type = TW SETUP, DS Channel

FREE OUTFALL CONDITIONS SPECIFIED

CONVERGENCE TOLERANCES...
Maximum Iterations= 40
Min. TW tolerance = .01 ft
Max. TW tolerance = .01 ft
Min. HW tolerance = .01 ft
Max. HW tolerance = .01 ft
Min. Q tolerance = .00 cfs
Max. Q tolerance = .00 cfs

***** COMPOSITE OUTFLOW SUMMARY *****

WS Elev, Total Q		Converge		Notes
Elev. ft	Q cfs	TW Elev ft	Error +/-ft	Contributing Structures
485.55	.00	Free Outfall		None contributing
485.65	.00	Free Outfall		None contributing
485.75	.00	Free Outfall		None contributing
485.85	.00	Free Outfall		None contributing
485.95	.00	Free Outfall		None contributing
486.05	.00	Free Outfall		None contributing
486.15	.00	Free Outfall		None contributing
486.25	.00	Free Outfall		None contributing
486.35	.00	Free Outfall		None contributing
486.45	.00	Free Outfall		None contributing
486.55	.00	Free Outfall		None contributing
486.65	.00	Free Outfall		None contributing
486.75	.00	Free Outfall		None contributing
486.85	.00	Free Outfall		None contributing
486.95	.00	Free Outfall		None contributing
487.05	.00	Free Outfall		None contributing
487.15	.00	Free Outfall		None contributing
487.25	.00	Free Outfall		None contributing
487.35	.00	Free Outfall		None contributing
487.45	.00	Free Outfall		None contributing
487.55	.00	Free Outfall		None contributing
487.65	.00	Free Outfall		None contributing
487.75	.00	Free Outfall		None contributing
487.85	.00	Free Outfall		None contributing
487.95	.00	Free Outfall		None contributing
488.05	.00	Free Outfall		None contributing
488.15	.00	Free Outfall		None contributing
488.25	.00	Free Outfall		None contributing
488.35	.00	Free Outfall		None contributing
488.45	.00	Free Outfall		None contributing
488.55	.00	Free Outfall		None contributing
488.65	.00	Free Outfall		None contributing
488.75	.00	Free Outfall		None contributing
488.85	.00	Free Outfall		None contributing
488.95	.00	Free Outfall		None contributing
489.05	.00	Free Outfall		None contributing
489.15	.00	Free Outfall		None contributing
489.25	.00	Free Outfall		None contributing

***** COMPOSITE OUTFLOW SUMMARY *****

WS Elev, Total Q		Converge		Notes
Elev. ft	Q cfs	TW Elev ft	Error +/-ft	Contributing Structures
489.35	.00	Free	Outfall	None contributing
489.45	.00	Free	Outfall	None contributing
489.55	.00	Free	Outfall	None contributing
489.65	.00	Free	Outfall	None contributing
489.75	.00	Free	Outfall	None contributing
489.85	.00	Free	Outfall	None contributing
489.95	.00	Free	Outfall	None contributing
490.05	.00	Free	Outfall	None contributing
490.15	.00	Free	Outfall	None contributing
490.25	.00	Free	Outfall	None contributing
490.35	.00	Free	Outfall	None contributing
490.45	.00	Free	Outfall	None contributing
490.55	.00	Free	Outfall	None contributing
490.65	.00	Free	Outfall	None contributing
490.75	.00	Free	Outfall	None contributing
490.85	.00	Free	Outfall	None contributing
490.95	.00	Free	Outfall	None contributing
491.05	.00	Free	Outfall	None contributing
491.15	.00	Free	Outfall	None contributing
491.25	.00	Free	Outfall	None contributing
491.35	.00	Free	Outfall	None contributing
491.45	.00	Free	Outfall	None contributing
491.55	.00	Free	Outfall	None contributing
491.65	.00	Free	Outfall	None contributing
491.75	.00	Free	Outfall	None contributing
491.85	.00	Free	Outfall	None contributing
491.95	.00	Free	Outfall	None contributing
492.05	.00	Free	Outfall	None contributing
492.15	.00	Free	Outfall	None contributing
492.25	.00	Free	Outfall	None contributing
492.35	.00	Free	Outfall	None contributing
492.45	.00	Free	Outfall	None contributing
492.50	.00	Free	Outfall	W1
492.55	1.17	Free	Outfall	W1
492.65	6.10	Free	Outfall	W1
492.66	6.72	Free	Outfall	R0 +W1
492.75	14.02	Free	Outfall	R0 +W1
492.85	24.47	Free	Outfall	R0 +W1

***** COMPOSITE OUTFLOW SUMMARY *****

WS Elev, Total Q		Converge		Notes
Elev. ft	Q cfs	TW Elev ft	Error +/-ft	Contributing Structures
492.95	36.85	Free	Outfall	R0 +W1
493.05	50.86	Free	Outfall	R0 +W1
493.15	66.34	Free	Outfall	R0 +W1
493.25	83.15	Free	Outfall	R0 +W1
493.35	101.19	Free	Outfall	R0 +W1
493.45	120.38	Free	Outfall	R0 +W1
493.55	140.67	Free	Outfall	R0 +W1
493.65	161.98	Free	Outfall	R0 +W1
493.75	184.28	Free	Outfall	R0 +W1
493.85	207.51	Free	Outfall	R0 +W1
493.95	231.66	Free	Outfall	R0 +W1
494.05	256.68	Free	Outfall	R0 +W1
494.15	279.07	Free	Outfall	R0 +W1
494.25	301.47	Free	Outfall	R0 +W1
494.35	324.40	Free	Outfall	R0 +W1
494.45	347.87	Free	Outfall	R0 +W1
494.55	371.85	Free	Outfall	R0 +W1
494.65	396.34	Free	Outfall	R0 +W1
494.75	421.32	Free	Outfall	R0 +W1
494.85	446.78	Free	Outfall	R0 +W1
494.95	472.73	Free	Outfall	R0 +W1
495.00	485.88	Free	Outfall	R0 +W1

Name.... WEST MOD. LFB

LEVEL POOL ROUTING DATA

HYG Dir = H:\PONDPACK\9000PLUS\9203F-DATA\
 Inflow HYG file = NONE STORED - WEST IN 2
 Outflow HYG file = NONE STORED - WEST OUT 2

Pond Node Data = WEST
 Pond Volume Data = WEST
 Pond Outlet Data = WEST MOD. LFB

No Infiltration

INITIAL CONDITIONS

 Starting WS Elev = 492.66 ft
 Starting Volume = 272543 cu.ft
 Starting Outflow = 6.72 cfs
 Starting Infiltr. = .00 cfs
 Starting Total Qout= 6.72 cfs
 Time Increment = 1.00 min

Elevation ft	Outflow cfs	Storage cu.ft	Area sq.ft	Infiltr. cfs	Q Total cfs	2S/t + O cfs
485.55	.00	0	0	.00	.00	.00
485.65	.00	2	51	.00	.00	.06
485.75	.00	14	204	.00	.00	.45
485.85	.00	46	459	.00	.00	1.53
485.95	.00	109	816	.00	.00	3.62
486.05	.00	212	1274	.00	.00	7.08
486.15	.00	367	1835	.00	.00	12.23
486.25	.00	583	2498	.00	.00	19.43
486.35	.00	870	3262	.00	.00	29.00
486.45	.00	1239	4129	.00	.00	41.29
486.55	.00	1699	5097	.00	.00	56.63
486.65	.00	2261	6168	.00	.00	75.38
486.75	.00	2936	7340	.00	.00	97.87
486.85	.00	3733	8614	.00	.00	124.42
486.95	.00	4662	9990	.00	.00	155.40
487.05	.00	5734	11469	.00	.00	191.14
487.15	.00	6959	13049	.00	.00	231.98
487.25	.00	8348	14731	.00	.00	278.25
487.35	.00	9909	16515	.00	.00	330.29
487.45	.00	11654	18401	.00	.00	388.46

Name.... WEST

File.... H:\PONDPACK\9000PLUS\9203F-DATA\AS-BUILT PROPOSED PHASE.MODIFIED BASIN.LFB.04.17.

LEVEL POOL ROUTING DATA

HYG Dir = H:\PONDPACK\9000PLUS\9203F-DATA\
 Inflow HYG file = NONE STORED - WEST IN 2
 Outflow HYG file = NONE STORED - WEST OUT 2

Pond Node Data = WEST
 Pond Volume Data = WEST
 Pond Outlet Data = WEST MOD. LFB

No Infiltration

INITIAL CONDITIONS

 Starting WS Elev = 492.66 ft
 Starting Volume = 272543 cu.ft
 Starting Outflow = 6.72 cfs
 Starting Infiltr. = .00 cfs
 Starting Total Qout= 6.72 cfs
 Time Increment = 1.00 min

Elevation ft	Outflow cfs	Storage cu.ft	Area sq.ft	Infiltr. cfs	Q Total cfs	2S/t + O cfs
487.55	.00	13592	20389	.00	.00	453.08
487.65	.00	15735	22479	.00	.00	524.50
487.75	.00	18092	24671	.00	.00	603.06
487.85	.00	20672	26964	.00	.00	689.07
487.95	.00	23488	29359	.00	.00	782.92
488.05	.00	26529	31111	.00	.00	884.30
488.15	.00	29692	32153	.00	.00	989.74
488.25	.00	32961	33213	.00	.00	1098.69
488.35	.00	36335	34289	.00	.00	1211.16
488.45	.00	39819	35383	.00	.00	1327.28
488.55	.00	43412	36494	.00	.00	1447.08
488.65	.00	47118	37623	.00	.00	1570.61
488.75	.00	50938	38768	.00	.00	1697.93
488.85	.00	54872	39930	.00	.00	1829.06
488.95	.00	58924	41110	.00	.00	1964.13
489.05	.00	63095	42307	.00	.00	2103.16
489.15	.00	67386	43521	.00	.00	2246.21
489.25	.00	71800	44753	.00	.00	2393.34
489.35	.00	76337	46001	.00	.00	2544.55
489.45	.00	81000	47267	.00	.00	2700.00

Name.... WEST

File.... H:\PONDPACK\9000PLUS\9203F-DATA\AS-BUILT PROPOSED PHASE.MODIFIED BASIN.LFB.04.17.

LEVEL POOL ROUTING DATA

HYG Dir = H:\PONDPACK\9000PLUS\9203F-DATA\
 Inflow HYG file = NONE STORED - WEST IN 2
 Outflow HYG file = NONE STORED - WEST OUT 2

Pond Node Data = WEST
 Pond Volume Data = WEST
 Pond Outlet Data = WEST MOD. LFB

No Infiltration

INITIAL CONDITIONS

 Starting WS Elev = 492.66 ft
 Starting Volume = 272543 cu.ft
 Starting Outflow = 6.72 cfs
 Starting Infiltr. = .00 cfs
 Starting Total Qout= 6.72 cfs
 Time Increment = 1.00 min

Elevation ft	Outflow cfs	Storage cu.ft	Area sq.ft	Infiltr. cfs	Q Total cfs	2S/t + O cfs
489.55	.00	85791	48550	.00	.00	2859.70
489.65	.00	90711	49850	.00	.00	3023.71
489.75	.00	95762	51167	.00	.00	3192.07
489.85	.00	100944	52501	.00	.00	3364.80
489.95	.00	106262	53853	.00	.00	3542.06
490.05	.00	111705	54790	.00	.00	3723.50
490.15	.00	117210	55301	.00	.00	3907.00
490.25	.00	122766	55815	.00	.00	4092.20
490.35	.00	128372	56331	.00	.00	4279.06
490.45	.00	134031	56849	.00	.00	4467.71
490.55	.00	139743	57370	.00	.00	4658.08
490.65	.00	145506	57893	.00	.00	4850.20
490.75	.00	151322	58419	.00	.00	5044.06
490.85	.00	157189	58947	.00	.00	5239.62
490.95	.00	163111	59477	.00	.00	5437.01
491.05	.00	169085	60010	.00	.00	5636.16
491.15	.00	175113	60545	.00	.00	5837.10
491.25	.00	181195	61082	.00	.00	6039.82
491.35	.00	187329	61622	.00	.00	6244.28
491.45	.00	193518	62164	.00	.00	6450.60

Name.... WEST

File.... H:\PONDPACK\9000PLUS\9203F-DATA\AS-BUILT PROPOSED PHASE.MODIFIED BASIN.LFB.04.17.

LEVEL POOL ROUTING DATA

HYG Dir = H:\PONDPACK\9000PLUS\9203F-DATA\
 Inflow HYG file = NONE STORED - WEST IN 2
 Outflow HYG file = NONE STORED - WEST OUT 2

Pond Node Data = WEST
 Pond Volume Data = WEST
 Pond Outlet Data = WEST MOD. LFB

No Infiltration

INITIAL CONDITIONS

 Starting WS Elev = 492.66 ft
 Starting Volume = 272543 cu.ft
 Starting Outflow = 6.72 cfs
 Starting Infiltr. = .00 cfs
 Starting Total Qout= 6.72 cfs
 Time Increment = 1.00 min

Elevation ft	Outflow cfs	Storage cu.ft	Area sq.ft	Infiltr. cfs	Q Total cfs	2S/t + O cfs
491.55	.00	199763	62709	.00	.00	6658.74
491.65	.00	206061	63256	.00	.00	6868.69
491.75	.00	212415	63805	.00	.00	7080.47
491.85	.00	218821	64357	.00	.00	7294.02
491.95	.00	225285	64911	.00	.00	7509.48
492.05	.00	231803	65412	.00	.00	7726.74
492.15	.00	238367	65860	.00	.00	7945.54
492.25	.00	244976	66310	.00	.00	8165.84
492.35	.00	251628	66761	.00	.00	8387.57
492.45	.00	258327	67214	.00	.00	8610.87
492.50	.00	261694	67441	.00	.00	8723.13
492.55	1.17	265071	67668	.00	1.17	8836.86
492.65	6.10	271861	68124	.00	6.10	9068.12
492.66	6.72	272543	68169	.00	6.72	9091.48
492.75	14.02	278697	68581	.00	14.02	9303.89
492.85	24.47	285576	69039	.00	24.47	9543.66
492.95	36.85	292504	69500	.00	36.85	9786.94
493.05	50.86	299477	69962	.00	50.86	10033.41
493.15	66.34	306497	70425	.00	66.34	10282.87
493.25	83.15	313563	70890	.00	83.15	10535.22

Name.... WEST

File.... H:\PONDPACK\9000PLUS\9203F-DATA\AS-BUILT PROPOSED PHASE.MODIFIED BASIN.LFB.04.17.

LEVEL POOL ROUTING DATA

HYG Dir = H:\PONDPACK\9000PLUS\9203F-DATA\
 Inflow HYG file = NONE STORED - WEST IN 2
 Outflow HYG file = NONE STORED - WEST OUT 2

Pond Node Data = WEST
 Pond Volume Data = WEST
 Pond Outlet Data = WEST MOD. LFB

No Infiltration

INITIAL CONDITIONS

 Starting WS Elev = 492.66 ft
 Starting Volume = 272543 cu.ft
 Starting Outflow = 6.72 cfs
 Starting Infiltr. = .00 cfs
 Starting Total Qout= 6.72 cfs
 Time Increment = 1.00 min

Elevation ft	Outflow cfs	Storage cu.ft	Area sq.ft	Infilt. cfs	Q Total cfs	2S/t + O cfs
493.35	101.19	320673	71356	.00	101.19	10790.28
493.45	120.38	327833	71824	.00	120.38	11048.12
493.55	140.67	335039	72294	.00	140.67	11308.62
493.65	161.98	342293	72765	.00	161.98	11571.71
493.75	184.28	349593	73237	.00	184.28	11837.36
493.85	207.51	356939	73711	.00	207.51	12105.44
493.95	231.66	364334	74187	.00	231.66	12376.10
494.05	256.68	371776	74640	.00	256.68	12649.19
494.15	279.07	379262	75071	.00	279.07	12921.12
494.25	301.47	386791	75503	.00	301.47	13194.49
494.35	324.40	394362	75937	.00	324.40	13469.76
494.45	347.87	401977	76372	.00	347.87	13747.09
494.55	371.85	409637	76808	.00	371.85	14026.38
494.65	396.34	417340	77245	.00	396.34	14307.64
494.75	421.32	425087	77683	.00	421.32	14590.85
494.85	446.78	432875	78123	.00	446.78	14875.93
494.95	472.73	440710	78564	.00	472.73	15163.04
495.00	485.88	444645	78785	.00	485.88	15307.36

Name.... WEST

File.... H:\PONDPACK\9000PLUS\9203F-DATA\AS-BUILT PROPOSED PHASE.MODIFIED BASIN.LFB.04.17.

SUMMARY FOR HYDROGRAPH ADDITION
 at Node: WEST IN

HYG Directory: H:\PONDPACK\9000PLUS\9203F-DATA\

```

=====
Upstream Link ID  Upstream Node ID  HYG file      HYG ID      HYG tag
-----
WEST              WEST              100 W
=====
    
```

```

INFLOWS TO:  WEST              IN
-----
HYG file      HYG ID      HYG tag      Volume      Peak Time      Peak Flow
              cu.ft      min      cfs
-----
              100 W              98640      8.00      82.20
    
```

```

TOTAL FLOW INTO:  WEST              IN
-----
HYG file      HYG ID      HYG tag      Volume      Peak Time      Peak Flow
              cu.ft      min      cfs
-----
              WEST              IN  100      98640      8.00      82.20
    
```

TOTAL NODE INFLOW...

HYG file =

HYG ID = WEST IN

HYG Tag = 100

 Peak Discharge = 82.20 cfs

Time to Peak = 8.00 min

HYG Volume = 98640 cu.ft

HYDROGRAPH ORDINATES (cfs)

Output Time increment = 1.00 min

Time | Time on left represents time for first value in each row.
 min | -----

.00	.00	10.28	20.55	30.83	41.10
5.00	51.38	61.65	71.93	82.20	82.20
10.00	82.20	82.20	82.20	82.20	82.20
15.00	82.20	82.20	82.20	82.20	82.20
20.00	82.20	71.93	61.65	51.38	41.10
25.00	30.83	20.55	10.28	.00	

LEVEL POOL ROUTING SUMMARY

HYG Dir = H:\PONDPACK\9000PLUS\9203F-DATA\
Inflow HYG file = NONE STORED - WEST IN 100
Outflow HYG file = NONE STORED - WEST OUT 100

Pond Node Data = WEST
Pond Volume Data = WEST
Pond Outlet Data = WEST MOD. LFB

No Infiltration

INITIAL CONDITIONS

Starting WS Elev = 492.66 ft
Starting Volume = 272543 cu.ft
Starting Outflow = 6.72 cfs
Starting Infiltr. = .00 cfs
Starting Total Qout= 6.72 cfs
Time Increment = 1.00 min

INFLOW/OUTFLOW HYDROGRAPH SUMMARY

Peak Inflow = 82.20 cfs at 8.00 min
Peak Outflow = 70.84 cfs at 21.00 min
Peak Elevation = 493.18 ft
Peak Storage = 308385 cu.ft

MASS BALANCE (cu.ft)

+ Initial Vol = 272543
+ HYG Vol IN = 98640
- Infiltration = 0
- HYG Vol OUT = 109481
- Retained Vol = 261703
Unrouted Vol = - cu.ft (.000% of Outflow Volume)

----- W -----

WEST... 4.01, 6.01, 6.06, 2.01,
 3.01, 6.08

WEST MOD. LFB... 5.01, 5.03

STORMWATER DETENTION CALCULATIONS

PROPOSED DEVELOPMENT

EAST BASIN

100 YR. LOW FLOW BLOCKED

Table of Contents

***** NETWORK SUMMARIES (DETAILED) *****

Watershed..... 100
Executive Summary (Nodes) 1.01

***** TIME VS.ELEV *****

EAST OUT 100
Time-Elev 2.01

***** TIME VS.VOL *****

EAST OUT 100
Time vs. Volume 3.01

***** POND VOLUMES *****

EAST..... Vol: Planimeter 4.01

***** OUTLET STRUCTURES *****

EAST MOD. LFB... Outlet Input Data 5.01
Composite Rating Curve 5.03

***** POND ROUTING *****

EAST..... Pond E-V-Q Table 6.01

Table of Contents

EAST	IN 100	
	Node: Pond Inflow Summary	6.06
EAST	OUT 100	
	Pond Routing Summary	6.08

Table of Contents (continued)

NETWORK SUMMARY -- NODES
 (Trun.= HYG Truncation: Blank=None; L=Left; R=Rt; LR=Left & Rt)

Node ID	Type	HYG Vol cu.ft	Trun.	Qpeak min	Qpeak cfs	Max WSEL ft
EAST	HYG	96120		12.00	80.10	
Outfall EAST	JCT	96117		20.00	77.02	
EAST	IN POND	96120		12.00	80.10	
EAST	OUT POND	96117		20.00	77.02	483.63
WEST	HYG	98640		8.00	82.20	
Outfall WEST	JCT	109481	L	21.00	70.84	
WEST	IN POND	98640		8.00	82.20	
WEST	OUT POND	109481	L	21.00	70.84	493.18

TIME vs. ELEVATION (ft)

Output Time increment = 1.00 min
Time on left represents time for first value in each row.

Time min					
.00	482.24	482.26	482.30	482.37	482.46
5.00	482.57	482.68	482.79	482.90	483.01
10.00	483.12	483.22	483.32	483.41	483.47
15.00	483.52	483.55	483.58	483.60	483.62
20.00	483.63	483.63	483.61	483.57	483.53
25.00	483.47	483.41	483.34	483.26	483.18
30.00	483.09	483.00	482.90	482.81	482.73
35.00	482.67	482.62	482.57	482.54	482.50
40.00	482.48	482.45	482.43	482.42	482.40
45.00	482.39	482.38	482.36	482.35	482.35
50.00	482.34	482.33	482.32	482.32	482.31
55.00	482.31	482.30	482.30	482.30	482.29
60.00	482.29	482.29	482.29	482.28	482.28
65.00	482.28	482.28	482.28	482.27	482.27
70.00	482.27	482.27	482.27	482.27	482.27
75.00	482.26	482.26	482.26	482.26	482.26
80.00	482.26	482.26	482.26	482.26	482.26
85.00	482.25	482.25	482.25	482.25	482.25
90.00	482.25	482.25	482.25	482.25	482.25
95.00	482.25	482.25	482.25	482.25	482.25
100.00	482.25	482.25	482.25	482.25	482.25
105.00	482.25	482.24	482.24	482.24	482.24
110.00	482.24	482.24	482.24	482.24	482.24
115.00	482.24	482.24	482.24	482.24	482.24
120.00	482.24	482.24	482.24	482.24	482.24
125.00	482.24	482.24	482.24	482.24	482.24
130.00	482.24	482.24	482.24	482.24	482.24
135.00	482.24	482.24	482.24	482.24	482.24
140.00	482.24	482.24	482.24	482.24	482.24
145.00	482.24	482.24	482.24	482.24	482.24
150.00	482.24	482.24	482.24	482.24	482.24
155.00	482.24	482.24	482.24	482.24	482.24
160.00	482.24	482.24	482.24		

TIME vs. VOLUME (cu.ft)

Time min	Output Time increment = 1.00 min				
	Time on left represents time for first value in each row.				
.00	22865	23060	23631	24537	25714
5.00	27098	28625	30241	31899	33574
10.00	35247	36905	38542	39979	41078
15.00	41917	42556	43047	43417	43696
20.00	43909	43896	43535	42906	42074
25.00	41090	39985	38783	37508	36172
30.00	34782	33337	31845	30480	29383
35.00	28497	27770	27170	26666	26246
40.00	25888	25579	25313	25084	24888
45.00	24717	24562	24423	24299	24187
50.00	24086	23996	23915	23842	23776
55.00	23718	23664	23617	23574	23535
60.00	23501	23469	23438	23410	23383
65.00	23357	23332	23309	23286	23265
70.00	23245	23226	23208	23191	23175
75.00	23159	23144	23130	23117	23105
80.00	23093	23081	23070	23060	23051
85.00	23041	23032	23024	23016	23009
90.00	23002	22995	22988	22982	22976
95.00	22971	22966	22961	22956	22951
100.00	22947	22943	22939	22935	22932
105.00	22929	22925	22922	22920	22917
110.00	22914	22912	22910	22907	22905
115.00	22903	22901	22899	22898	22896
120.00	22895	22893	22892	22890	22889
125.00	22888	22887	22886	22885	22884
130.00	22883	22882	22881	22880	22880
135.00	22879	22878	22878	22877	22877
140.00	22876	22875	22875	22874	22874
145.00	22874	22873	22873	22872	22872
150.00	22872	22871	22871	22871	22871
155.00	22870	22870	22870	22869	22869
160.00	22869	22869	22869		

POND VOLUME CALCULATIONS

Planimeter scale: 1.00 ft/in

Elevation (ft)	Planimeter (sq.in)	Area (sq.ft)	A1+A2+sqr(A1*A2) (sq.ft)	Volume (cu.ft)	Volume Sum (cu.ft)
477.19	.000	0	0	0	0
478.00	605.000	605	605	163	163
480.00	4509.000	4509	6766	4510	4674
482.00	11365.000	11365	23033	15355	20029
484.00	20067.000	20067	46534	31022	51051
485.00	22444.000	22444	63733	21244	72296
485.50	23656.000	23656	69142	11524	83819

POND VOLUME EQUATIONS

* Incremental volume computed by the Conic Method for Reservoir Volumes.

$$\text{Volume} = (1/3) * (\text{EL2}-\text{EL1}) * (\text{Area1} + \text{Area2} + \text{sq.rt.}(\text{Area1}*\text{Area2}))$$

where: EL1, EL2 = Lower and upper elevations of the increment
 Area1,Area2 = Areas computed for EL1, EL2, respectively
 Volume = Incremental volume between EL1 and EL2

Name.... EAST

File.... H:\PONDPACK\9000PLUS\9203F-DATA\AS-BUILT PROPOSED PHASE.MODIFIED BASIN.LFB.04.17.

REQUESTED POND WS ELEVATIONS:

Min. Elev.= 477.19 ft
 Increment = .10 ft
 Max. Elev.= 485.50 ft

OUTLET CONNECTIVITY

---> Forward Flow Only (UpStream to DnStream)
 <--- Reverse Flow Only (DnStream to UpStream)
 <---> Forward and Reverse Both Allowed

Structure	No.	Outfall	E1, ft	E2, ft
Stand Pipe TW SETUP, DS Channel	R0	---> TW	482.240	485.500

OUTLET STRUCTURE INPUT DATA

Structure ID = R0
Structure Type = Stand Pipe

of Openings = 1
Invert Elev. = 482.24 ft
Diameter = 5.0000 ft
Orifice Area = 19.6350 sq.ft
Orifice Coeff. = .600
Weir Length = 15.71 ft
Weir Coeff. = 3.000
K, Reverse = 1.000
Mannings n = .0000
Kev, Charged Riser = .000
Weir Submergence = No
Orifice H to crest = Yes

Structure ID = TW
Structure Type = TW SETUP, DS Channel

FREE OUTFALL CONDITIONS SPECIFIED

CONVERGENCE TOLERANCES...
Maximum Iterations = 40
Min. TW tolerance = .01 ft
Max. TW tolerance = .01 ft
Min. HW tolerance = .01 ft
Max. HW tolerance = .01 ft
Min. Q tolerance = .00 cfs
Max. Q tolerance = .00 cfs

Name.... EAST MOD. LFB

File.... H:\PONDPACK\9000PLUS\9203F-DATA\AS-BUILT PROPOSED PHASE.MODIFIED BASIN.LFB.04.17.

***** COMPOSITE OUTFLOW SUMMARY *****

WS Elev, Total Q		Converge		Notes
Elev. ft	Q cfs	TW Elev ft	Error +/-ft	Contributing Structures
477.19	.00	Free Outfall		None contributing
477.29	.00	Free Outfall		None contributing
477.39	.00	Free Outfall		None contributing
477.49	.00	Free Outfall		None contributing
477.59	.00	Free Outfall		None contributing
477.69	.00	Free Outfall		None contributing
477.79	.00	Free Outfall		None contributing
477.89	.00	Free Outfall		None contributing
477.99	.00	Free Outfall		None contributing
478.09	.00	Free Outfall		None contributing
478.19	.00	Free Outfall		None contributing
478.29	.00	Free Outfall		None contributing
478.39	.00	Free Outfall		None contributing
478.49	.00	Free Outfall		None contributing
478.59	.00	Free Outfall		None contributing
478.69	.00	Free Outfall		None contributing
478.79	.00	Free Outfall		None contributing
478.89	.00	Free Outfall		None contributing
478.99	.00	Free Outfall		None contributing
479.09	.00	Free Outfall		None contributing
479.19	.00	Free Outfall		None contributing
479.29	.00	Free Outfall		None contributing
479.39	.00	Free Outfall		None contributing
479.49	.00	Free Outfall		None contributing
479.59	.00	Free Outfall		None contributing
479.69	.00	Free Outfall		None contributing
479.79	.00	Free Outfall		None contributing
479.89	.00	Free Outfall		None contributing
479.99	.00	Free Outfall		None contributing
480.09	.00	Free Outfall		None contributing
480.19	.00	Free Outfall		None contributing
480.29	.00	Free Outfall		None contributing
480.39	.00	Free Outfall		None contributing
480.49	.00	Free Outfall		None contributing
480.59	.00	Free Outfall		None contributing
480.69	.00	Free Outfall		None contributing
480.79	.00	Free Outfall		None contributing
480.89	.00	Free Outfall		None contributing

***** COMPOSITE OUTFLOW SUMMARY *****

WS Elev, Total Q		Converge		Notes
Elev. ft	Q cfs	TW Elev ft	Error +/-ft	Contributing Structures
480.99	.00	Free	Outfall	None contributing
481.09	.00	Free	Outfall	None contributing
481.19	.00	Free	Outfall	None contributing
481.29	.00	Free	Outfall	None contributing
481.39	.00	Free	Outfall	None contributing
481.49	.00	Free	Outfall	None contributing
481.59	.00	Free	Outfall	None contributing
481.69	.00	Free	Outfall	None contributing
481.79	.00	Free	Outfall	None contributing
481.89	.00	Free	Outfall	None contributing
481.99	.00	Free	Outfall	None contributing
482.09	.00	Free	Outfall	None contributing
482.19	.00	Free	Outfall	None contributing
482.24	.00	Free	Outfall	R0
482.29	.53	Free	Outfall	R0
482.39	2.74	Free	Outfall	R0
482.49	5.89	Free	Outfall	R0
482.59	9.76	Free	Outfall	R0
482.69	14.23	Free	Outfall	R0
482.79	19.22	Free	Outfall	R0
482.89	24.70	Free	Outfall	R0
482.99	30.61	Free	Outfall	R0
483.09	36.93	Free	Outfall	R0
483.19	43.63	Free	Outfall	R0
483.29	50.70	Free	Outfall	R0
483.39	58.12	Free	Outfall	R0
483.49	65.86	Free	Outfall	R0
483.59	73.92	Free	Outfall	R0
483.69	82.28	Free	Outfall	R0
483.79	90.94	Free	Outfall	R0
483.89	99.88	Free	Outfall	R0
483.99	109.09	Free	Outfall	R0
484.09	118.58	Free	Outfall	R0
484.19	128.32	Free	Outfall	R0
484.29	135.31	Free	Outfall	R0
484.39	138.57	Free	Outfall	R0
484.49	141.76	Free	Outfall	R0
484.59	144.87	Free	Outfall	R0

***** COMPOSITE OUTFLOW SUMMARY *****

WS Elev, Total Q		Converge		Notes
Elev.	Q	TW Elev	Error	Contributing Structures
ft	cfs	ft	+/-ft	
484.69	147.92	Free	Outfall	R0
484.79	150.91	Free	Outfall	R0
484.89	153.84	Free	Outfall	R0
484.99	156.72	Free	Outfall	R0
485.09	159.54	Free	Outfall	R0
485.19	162.32	Free	Outfall	R0
485.29	165.04	Free	Outfall	R0
485.39	167.73	Free	Outfall	R0
485.49	170.37	Free	Outfall	R0
485.50	170.63	Free	Outfall	R0

Name.... EAST MOD. LFB

LEVEL POOL ROUTING DATA

HYG Dir = H:\PONDPACK\9000PLUS\9203F-DATA\
 Inflow HYG file = NONE STORED - EAST IN 2
 Outflow HYG file = NONE STORED - EAST OUT 2

Pond Node Data = EAST
 Pond Volume Data = EAST
 Pond Outlet Data = EAST MOD. LFB

No Infiltration

INITIAL CONDITIONS

 Starting WS Elev = 482.24 ft
 Starting Volume = 22865 cu.ft
 Starting Outflow = .00 cfs
 Starting Infiltr. = .00 cfs
 Starting Total Qout= .00 cfs
 Time Increment = 1.00 min

Elevation ft	Outflow cfs	Storage cu.ft	Area sq.ft	Infilt. cfs	Q Total cfs	2S/t + O cfs
477.19	.00	0	0	.00	.00	.00
477.29	.00	0	9	.00	.00	.01
477.39	.00	2	37	.00	.00	.08
477.49	.00	8	83	.00	.00	.28
477.59	.00	20	148	.00	.00	.66
477.69	.00	38	231	.00	.00	1.28
477.79	.00	66	332	.00	.00	2.21
477.89	.00	105	452	.00	.00	3.51
477.99	.00	157	590	.00	.00	5.25
478.09	.00	222	703	.00	.00	7.40
478.19	.00	298	820	.00	.00	9.94
478.29	.00	386	947	.00	.00	12.88
478.39	.00	488	1082	.00	.00	16.26
478.49	.00	603	1227	.00	.00	20.11
478.59	.00	733	1380	.00	.00	24.45
478.69	.00	880	1543	.00	.00	29.32
478.79	.00	1042	1714	.00	.00	34.74
478.89	.00	1223	1895	.00	.00	40.76
478.99	.00	1422	2085	.00	.00	47.39
479.09	.00	1640	2284	.00	.00	54.67

Name.... EAST

File.... H:\PONDPACK\9000PLUS\9203F-DATA\AS-BUILT PROPOSED PHASE.MODIFIED BASIN.LFB.04.17.

LEVEL POOL ROUTING DATA

HYG Dir = H:\PONDPACK\9000PLUS\9203F-DATA\
 Inflow HYG file = NONE STORED - EAST IN 2
 Outflow HYG file = NONE STORED - EAST OUT 2

Pond Node Data = EAST
 Pond Volume Data = EAST
 Pond Outlet Data = EAST MOD. LFB

No Infiltration

INITIAL CONDITIONS

 Starting WS Elev = 482.24 ft
 Starting Volume = 22865 cu.ft
 Starting Outflow = .00 cfs
 Starting Infiltr. = .00 cfs
 Starting Total Qout= .00 cfs
 Time Increment = 1.00 min

Elevation ft	Outflow cfs	Storage cu.ft	Area sq.ft	Infiltr. cfs	Q Total cfs	2S/t + O cfs
479.19	.00	1879	2492	.00	.00	62.62
479.29	.00	2139	2708	.00	.00	71.29
479.39	.00	2421	2934	.00	.00	80.69
479.49	.00	2726	3169	.00	.00	90.86
479.59	.00	3055	3414	.00	.00	101.83
479.69	.00	3409	3667	.00	.00	113.63
479.79	.00	3789	3929	.00	.00	126.28
479.89	.00	4195	4200	.00	.00	139.83
479.99	.00	4629	4480	.00	.00	154.29
480.09	.00	5090	4751	.00	.00	169.68
480.19	.00	5579	5026	.00	.00	185.97
480.29	.00	6096	5310	.00	.00	203.20
480.39	.00	6642	5602	.00	.00	221.39
480.49	.00	7216	5901	.00	.00	240.55
480.59	.00	7822	6208	.00	.00	260.73
480.69	.00	8458	6523	.00	.00	281.94
480.79	.00	9127	6845	.00	.00	304.22
480.89	.00	9828	7175	.00	.00	327.59
480.99	.00	10562	7513	.00	.00	352.06
481.09	.00	11331	7859	.00	.00	377.68

Name.... EAST

File.... H:\PONDPACK\9000PLUS\9203F-DATA\AS-BUILT PROPOSED PHASE.MODIFIED BASIN.LFB.04.17.

LEVEL POOL ROUTING DATA

HYG Dir = H:\PONDPACK\9000PLUS\9203F-DATA\
 Inflow HYG file = NONE STORED - EAST IN 2
 Outflow HYG file = NONE STORED - EAST OUT 2

Pond Node Data = EAST
 Pond Volume Data = EAST
 Pond Outlet Data = EAST MOD. LFB

No Infiltration

INITIAL CONDITIONS

 Starting WS Elev = 482.24 ft
 Starting Volume = 22865 cu.ft
 Starting Outflow = .00 cfs
 Starting Infiltr. = .00 cfs
 Starting Total Qout = .00 cfs
 Time Increment = 1.00 min

Elevation ft	Outflow cfs	Storage cu.ft	Area sq.ft	Infiltr. cfs	Q Total cfs	2S/t + O cfs
481.19	.00	12134	8213	.00	.00	404.47
481.29	.00	12974	8575	.00	.00	432.45
481.39	.00	13849	8944	.00	.00	461.65
481.49	.00	14762	9321	.00	.00	492.08
481.59	.00	15714	9706	.00	.00	523.79
481.69	.00	16704	10098	.00	.00	556.80
481.79	.00	17734	10499	.00	.00	591.13
481.89	.00	18804	10907	.00	.00	626.80
481.99	.00	19915	11323	.00	.00	663.84
482.09	.00	21067	11704	.00	.00	702.23
482.19	.00	22256	12086	.00	.00	741.88
482.24	.00	22865	12279	.00	.00	762.18
482.29	.53	23484	12475	.00	.53	783.34
482.39	2.74	24752	12869	.00	2.74	827.79
482.49	5.89	26058	13270	.00	5.89	874.49
482.59	9.76	27406	13677	.00	9.76	923.27
482.69	14.23	28794	14090	.00	14.23	974.02
482.79	19.22	30224	14509	.00	19.22	1026.68
482.89	24.70	31696	14934	.00	24.70	1081.23
482.99	30.61	33211	15365	.00	30.61	1137.62

Name.... EAST

File.... H:\PONDPACK\9000PLUS\9203F-DATA\AS-BUILT PROPOSED PHASE.MODIFIED BASIN.LFB.04.17.

LEVEL POOL ROUTING DATA

HYG Dir = H:\PONDPACK\9000PLUS\9203F-DATA\
 Inflow HYG file = NONE STORED - EAST IN 2
 Outflow HYG file = NONE STORED - EAST OUT 2

Pond Node Data = EAST
 Pond Volume Data = EAST
 Pond Outlet Data = EAST MOD. LFB

No Infiltration

INITIAL CONDITIONS

 Starting WS Elev = 482.24 ft
 Starting Volume = 22865 cu.ft
 Starting Outflow = .00 cfs
 Starting Infiltr. = .00 cfs
 Starting Total Qout= .00 cfs
 Time Increment = 1.00 min

Elevation ft	Outflow cfs	Storage cu.ft	Area sq.ft	Infilt. cfs	Q Total cfs	2S/t + O cfs
483.09	36.93	34769	15803	.00	36.93	1195.89
483.19	43.63	36372	16247	.00	43.63	1256.02
483.29	50.70	38019	16697	.00	50.70	1317.99
483.39	58.12	39711	17153	.00	58.12	1381.82
483.49	65.86	41449	17615	.00	65.86	1447.49
483.59	73.92	43234	18083	.00	73.92	1515.05
483.69	82.28	45066	18557	.00	82.28	1584.48
483.79	90.94	46946	19038	.00	90.94	1655.80
483.89	99.88	48874	19525	.00	99.88	1729.01
483.99	109.09	50851	20017	.00	109.09	1804.11
484.09	118.58	52867	20275	.00	118.58	1880.79
484.19	128.32	54906	20508	.00	128.32	1958.52
484.29	135.31	56969	20743	.00	135.31	2034.26
484.39	138.57	59055	20978	.00	138.57	2107.06
484.49	141.76	61164	21215	.00	141.76	2180.55
484.59	144.87	63297	21453	.00	144.87	2254.78
484.69	147.92	65455	21693	.00	147.92	2329.75
484.79	150.91	67636	21934	.00	150.91	2405.45
484.89	153.84	69842	22176	.00	153.84	2481.90
484.99	156.72	72071	22420	.00	156.72	2559.08

Name.... EAST

File.... H:\PONDPACK\9000PLUS\9203F-DATA\AS-BUILT PROPOSED PHASE.MODIFIED BASIN.LFB.04.17.

LEVEL POOL ROUTING DATA

HYG Dir = H:\PONDPACK\9000PLUS\9203F-DATA\
 Inflow HYG file = NONE STORED - EAST IN 2
 Outflow HYG file = NONE STORED - EAST OUT 2

Pond Node Data = EAST
 Pond Volume Data = EAST
 Pond Outlet Data = EAST MOD. LFB

No Infiltration

INITIAL CONDITIONS

 Starting WS Elev = 482.24 ft
 Starting Volume = 22865 cu.ft
 Starting Outflow = .00 cfs
 Starting Infiltr. = .00 cfs
 Starting Total Qout= .00 cfs
 Time Increment = 1.00 min

Elevation ft	Outflow cfs	Storage cu.ft	Area sq.ft	Infiltr. cfs	Q Total cfs	2S/t + O cfs
485.09	159.54	74325	22660	.00	159.54	2637.05
485.19	162.32	76603	22901	.00	162.32	2715.76
485.29	165.04	78906	23143	.00	165.04	2795.23
485.39	167.73	81232	23387	.00	167.73	2875.47
485.49	170.37	83583	23631	.00	170.37	2956.45
485.50	170.63	83819	23656	.00	170.63	2964.60

Name.... EAST

File.... H:\PONDPACK\9000PLUS\9203F-DATA\AS-BUILT PROPOSED PHASE.MODIFIED BASIN.LFB.04.17.

SUMMARY FOR HYDROGRAPH ADDITION
at Node: EAST IN

HYG Directory: H:\PONDPACK\9000PLUS\9203F-DATA\

```

=====
Upstream Link ID  Upstream Node ID  HYG file      HYG ID      HYG tag
-----
EAST              EAST              100 E
=====

```

```

INFLOWS TO:  EAST              IN
-----
HYG file      HYG ID      HYG tag      Volume      Peak Time      Peak Flow
              cu.ft      min      cfs
-----
              100 E              96120      12.00      80.10

```

```

TOTAL FLOW INTO:  EAST              IN
-----
HYG file      HYG ID      HYG tag      Volume      Peak Time      Peak Flow
              cu.ft      min      cfs
-----
              EAST              IN  100      96120      12.00      80.10

```

TOTAL NODE INFLOW...

HYG file =

HYG ID = EAST IN

HYG Tag = 100

```

-----
Peak Discharge =      80.10 cfs
Time to Peak   =      12.00 min
HYG Volume     =      96120 cu.ft
-----

```

HYDROGRAPH ORDINATES (cfs)

Output Time increment = 1.00 min

Time | min | Time on left represents time for first value in each row.

Time min	0.00	5.00	10.00	15.00	20.00	25.00	30.00
0.00	.00	6.68	13.35	20.03	26.70		
5.00	33.38	40.05	46.73	53.40	60.08		
10.00	66.75	73.43	80.10	80.10	80.10		
15.00	80.10	80.10	80.10	80.10	80.10		
20.00	80.10	73.43	66.75	60.08	53.40		
25.00	46.73	40.05	33.38	26.70	20.03		
30.00	13.35	6.68	.00				

LEVEL POOL ROUTING SUMMARY

HYG Dir = H:\PONDPACK\9000PLUS\9203F-DATA\
Inflow HYG file = NONE STORED - EAST IN 100
Outflow HYG file = NONE STORED - EAST OUT 100

Pond Node Data = EAST
Pond Volume Data = EAST
Pond Outlet Data = EAST MOD. LFB

No Infiltration

INITIAL CONDITIONS

Starting WS Elev = 482.24 ft
Starting Volume = 22865 cu.ft
Starting Outflow = .00 cfs
Starting Infiltr. = .00 cfs
Starting Total Qout= .00 cfs
Time Increment = 1.00 min

INFLOW/OUTFLOW HYDROGRAPH SUMMARY

Peak Inflow = 80.10 cfs at 12.00 min
Peak Outflow = 77.02 cfs at 20.00 min
Peak Elevation = 483.63 ft
Peak Storage = 43909 cu.ft

MASS BALANCE (cu.ft)

+ Initial Vol = 22865
+ HYG Vol IN = 96120
- Infiltration = 0
- HYG Vol OUT = 96117
- Retained Vol = 22869
Unrouted Vol = - cu.ft (.000% of Inflow Volume)

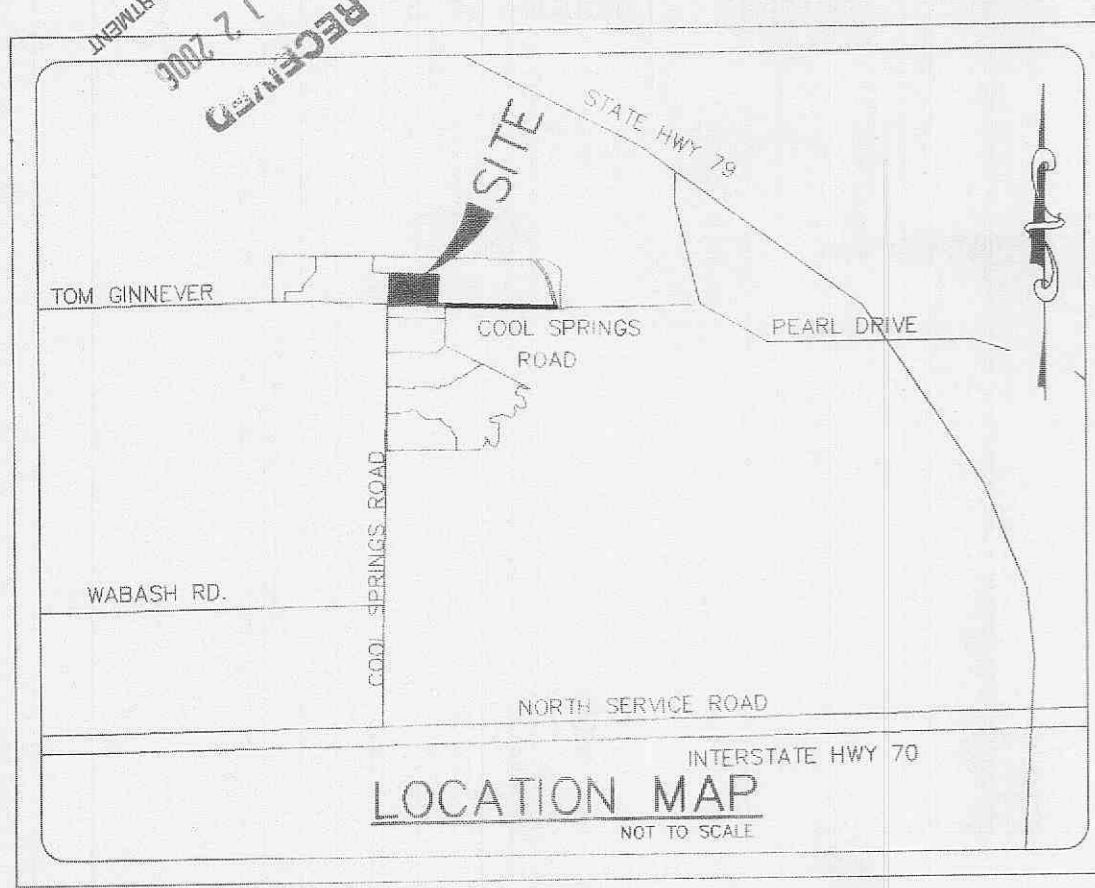

A SET OF AS-BUILT PLANS FOR
THE LIVING WORD CHRISTIAN SCHOOL
 A TRACT OF LAND IN
 SECTION 21, 22, U.S. SURVEY 63 AND 3070,
 TOWNSHIP 47 NORTH, RANGE 3 EAST,
 ST. CHARLES COUNTY, MISSOURI

GENERAL NOTES

- 1) UNDERGROUND UTILITIES HAVE BEEN PLOTTED FROM AVAILABLE INFORMATION AND THEREFORE THEIR LOCATIONS SHALL BE CONSIDERED APPROXIMATE ONLY. THE VERIFICATION OF THE LOCATION OF ALL UNDERGROUND UTILITIES, EITHER SHOWN OR NOT SHOWN ON THESE PLANS SHALL BE THE RESPONSIBILITY OF THE CONTRACTOR, AND SHALL BE LOCATED PRIOR TO ANY GRADING OR CONSTRUCTION OF THE IMPROVEMENTS.
- 2) ALL FILLED PLACES, INCLUDING TRENCH BACKFILLS, UNDER BUILDINGS, PROPOSED STORM AND SANITARY SEWER LINES AND/OR PAVED AREAS, SHALL BE COMPACTED TO 90 % MAXIMUM DENSITY AS DETERMINED BY THE "MODIFIED AASHTO T-180 COMPACTION TEST," (A.S.T.M.-D-1557). ALL FILLED PLACES WITHIN PUBLIC ROADWAYS SHALL BE COMPACTED TO 95 % OF MAXIMUM DENSITY AS DETERMINED BY THE "STANDARD PROCTOR TEST AASHTO T-99, METHOD C" (A.S.T.M. D-698).
- 3) ALL TRENCH BACKFILLS SHALL BE COMPACTED TO 90% OF THE MAXIMUM DENSITY AS DETERMINED BY THE "MODIFIED AASHTO T-180 COMPACTION TEST," (A.S.T.M.-D-1557). ALL TRENCH BACKFILLS UNDER PAVED AREAS INCLUDING SIDEWALKS SHALL BE GRANULAR FILL. ALL OTHER TRENCH BACK FILLS MAY BE EARTH MATERIAL (FREE OF LARGE CLOUDS OR STONES).
- 4) NO AREA SHALL BE CLEARED WITHOUT THE PERMISSION OF THE PROJECT ENGINEER.
- 5) ALL GRADES SHALL BE WITHIN 0.2 FEET OF THOSE SHOWN ON THE GRADING PLAN.
- 6) NO SLOPE SHALL BE STEEPER THAN 3:1. ALL SLOPES SHALL BE SODDED OR SEEDED AND MULCHED.
- 7) ALL CONSTRUCTION AND MATERIALS USED SHALL CONFORM TO CURRENT CITY OF O'FALLON STANDARDS.
- 8) ALL MECHANICAL EQUIPMENT TO BE SCREENED FROM PUBLIC VIEW.
- 9) PROPOSED BUILDING WILL COMPLY WITH CURRENT AMERICAN DISABILITY ACT REQUIREMENTS.
- 10) SEE ARCHITECTURAL DRAWING FOR ALL BUILDING DIMENSIONS, SERVICE CONNECTIONS, DETAILS, ETC.
- 11) ALL UTILITIES SHOWN ARE EXISTING UNLESS OTHERWISE NOTED. ALL NEW UTILITIES SHALL BE LOCATED UNDERGROUND.
- 12) ALL DIMENSIONS ARE TO BACK OF CURB UNLESS OTHERWISE NOTED.
- 13) MINIMUM TREE REQUIREMENTS PER ZONING ORDINANCE:
 STREET TREES: 1,170 L.F. FRONTAGE
 1 TREE / 40 L.F. = 30 TREES
 ADDITIONAL TREES: 97,650 S.F. OPEN SPACE
 1 TREE / 4000 S.F. = 24 TREES
 TOTAL TREES REQUIRED: 62 TREES
- 14) TOTAL TREES PROPOSED: 62 TREES (SEE TREE INVENTORY & LANDCAPE LEGEND)
- 15) THE DEVELOPER SHALL COMPLY WITH CURRENT TREE PRESERVATION ORDINANCE NUMBER 1689 AND PROVIDE LANDSCAPING AS SET FORTH IN ARTICLE 23 OF THE CITY OF O'FALLON ZONING ORDINANCES. (SEE TREE INVENTORY & LANDSCAPE LEGEND)
- 16) THE DEVELOPER SHALL COMPLY WITH CURRENT ARTICLE 13 PERFORMANCE STANDARDS.
- 17) THE DEVELOPER SHALL COMPLY WITH THE TREE PRESERVATION ORDINANCE.
- 18) THE ENTRANCES TO THE SCHOOL WILL DETERMINE THE LOCATION OF THE ENTRANCES TO THE COMMERCIAL ZONING TO THE SOUTH.
- 19) ONE LANE OF ROADWAY SHALL REMAIN OPEN AT ALL TIMES AND TRAFFIC CONTROL SHALL MEET MISSOURI DEPARTMENT OF TRANSPORTATION SPECIFICATIONS.

DEVELOPMENT NOTES

1. Area of Tract: 20 Acres
2. Existing Zoning: R-1
3. Proposed Use: School
4. Area of Building: 24,312 SQ. FT.
5. The required height and building setbacks are as follows:
 Minimum Front Yard: 25 feet
 Minimum Side Yard: 6 feet
 Minimum Rear Yard: 25 feet
 Maximum Height of Building: 35 feet
6. Owner under contract: The Living Word Christian School
7. Site is served by:
 City of O'Fallon Sewer
 Union Electric Company
 St. Charles Gas Company
 City of O'Fallon Water
 GTE Telephone Company
 Fort Zumwalt School District
 O'Fallon Fire Protection District
8. This tract is determined to be outside the 500 year flood plan per F.I.R.M. #29183 C 0235 E, dated Aug. 2, 1996.
9. Topographic information is per Aerial Topographic Survey by Walker and Associates.
10. Parking Required: One (1) space per three (3) students in day school, plus one (1) space per two (2) facility members.
 $(250/3) + (20/2) = 73$ required parking spaces
 Parking Provided: 125 spaces with 8 handicap spaces.
11. Loading/Unloading Spaces Required: One (1) loading/unloading space if over 5,000 square feet of gross floor area. One (1) additional loading/unloading space shall be provided for every additional 20,000 square feet of gross floor space = 3 spaces.
 Loading/Unloading Spaces Provided: Three (3) spaces.
12. SITE COVERAGE CALCULATIONS:
 BUILDING = 24,312 SQ. FT.
 PAVEMENT = 142,474 SQ. FT.
 GREEN SPACE = 704,685 SQ. FT.
13. LANDSCAPE CALCULATIONS:
 REQUIRED: 270 S.F. X TOTAL NUMBER OF PARKING SPACES X 6% = TOTAL S.F. OF LANDSCAPING REQUIRED
 $270 \times 181 \times 6\% = 2,932$ S.F. REQUIRED
 PROVIDED: 21,788 S.F. OF LANDSCAPING PROVIDED

SHEET INDEX

- 1 - COVER SHEET
- 2 - SITE PLAN
- 3 - SANITARY SEWER PROFILE
- 4 - STORM SEWER PROFILE
- 5 - PROFILES AND CROSS SECTIONS

LANDSCAPE LEGEND

QTY. 62 INDICATES PROPOSED HARDWOOD TREE (ashes, oaks, maples, birches, sweet gum)
 LANDSCAPING AS DEPICTED IS SUBJECT TO FINAL DESIGN BY A QUALIFIED LANDSCAPE DESIGNER

SEWER MEASUREMENTS

THE EXISTING SEWER LENGTHS, SIZES, FLOWLINES, DEPTHS OF STRUCTURES AND SEWERS AND LOCATIONS WITH RESPECT TO EXISTING OR PROPOSED EASEMENTS HAVE BEEN MEASURED. THE RESULTS OF THOSE MEASUREMENTS ARE SHOWN ON THIS SET OF FINAL MEASUREMENT PLANS.
 ALL PUBLIC SEWERS ARE LOCATED WITHIN DESIGNATED EXISTING OR PROPOSED EASEMENTS EXCEPT AS FOLLOWS:

SIGNED: [Signature]
 P.E./L.S. OAKLEY NUMBER LS-2205 DATE

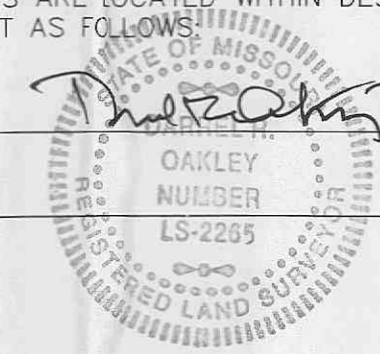

AS-BUILTS ADDED FEBRUARY 2005

THE LIVING WORD CHRISTIAN SCHOOL
PREPARED FOR: LEPIQUE AND ORNE
423 JACKSON STREET
ST. CHARLES, MO 63301
314-947-0099

DISCLAIMER OF RESPONSIBILITY
 I hereby specify that the documents intended to be authorized by my seal are limited to this sheet, and I hereby disclaim any responsibility for all other Drawings, Specifications, Estimates, Reports or other documents or instruments relating to or intended to be used for any part or parts of the architectural or engineering project or survey.

Copyright 2006
 Box Engineering Company, Inc.
 All Rights Reserved

REVISIONS	
4/6/06	CITY COMMENTS

B74

**ENGINEERING
 PLANNING
 SURVEYING**

221 Point West Blvd.
 St. Charles, MO 63301
 636-928-5552
 FAX 928-1718

2-23-05
 DATE
 97-9203F
 PROJECT NUMBER
 1 OF 5
 SHEET OF
 9203FASB.DWG
 FILE NAME
 BCC
 DRAWN
 DRO
 DESIGNED CHECKED

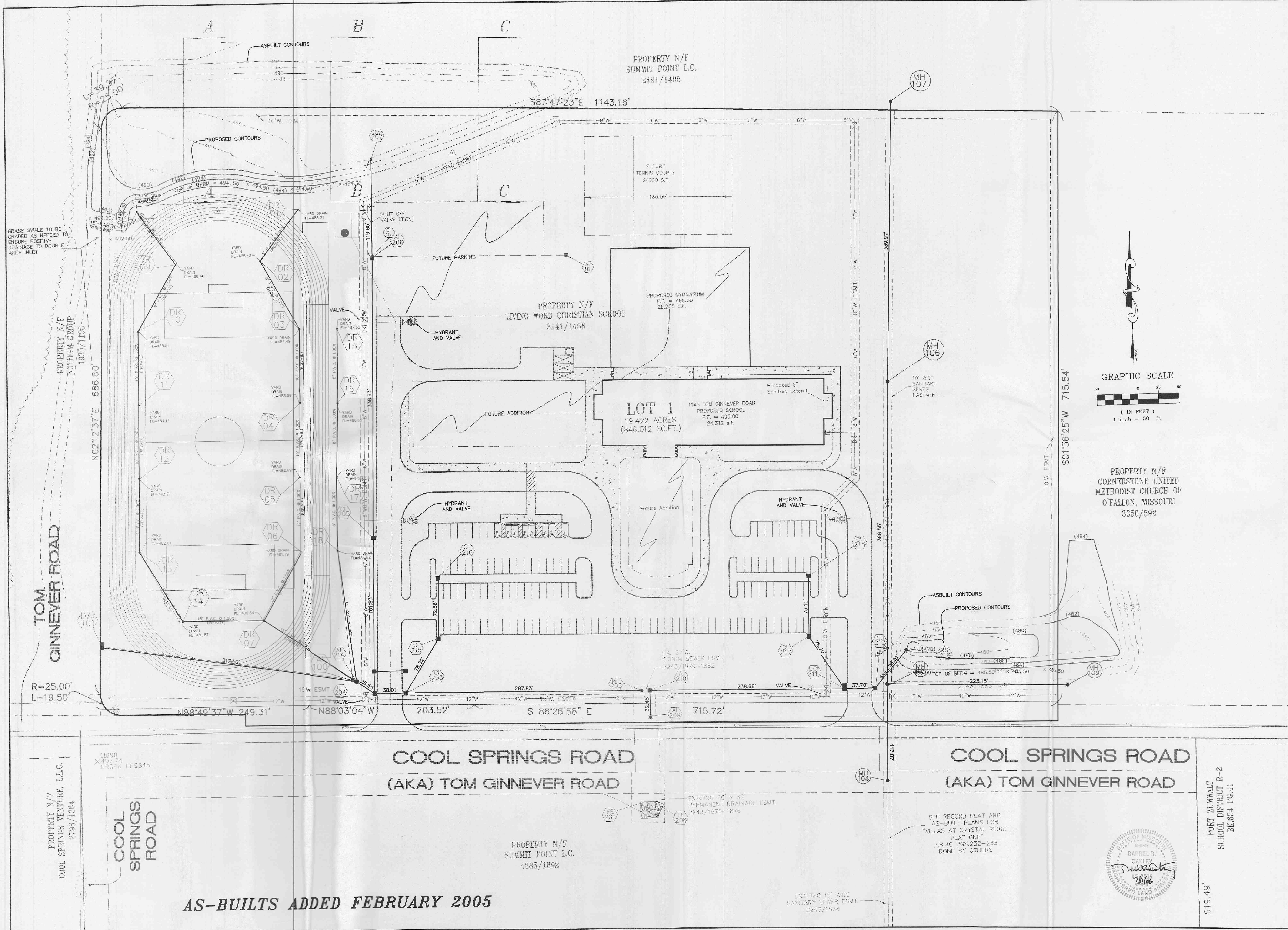

PROPERTY N/F
SUMMIT POINT L.C.
2491/1495

PROPERTY N/F
LIVING WORD CHRISTIAN SCHOOL
3141/1458

LOT 1
19.422 ACRES
(846,012 SQ.FT.)
1145 TOM GINNEVER ROAD
PROPOSED SCHOOL
F.F. = 496.00
24,312 s.f.

PROPERTY N/F
CORNERSTONE UNITED
METHODIST CHURCH OF
O'FALLON, MISSOURI
3350/592

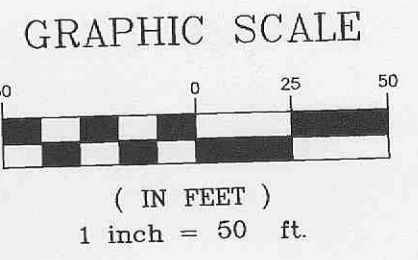

THE LIVING WORD CHRISTIAN SCHOOL
LEPIQUE AND ORNE
423 JACKSON STREET
ST. CHARLES, MO 63301
314-947-0099

DISCLAIMER OF RESPONSIBILITY
I hereby specify that the documents intended to be authenticated by my seal are limited to this sheet, and I hereby disclaim any responsibility for all other Drawings, Specifications, Estimates, Reports or other documents or instruments relating to or intended to be used for any part or parts of the architectural or engineering project or survey.

Copyright 2006
Sox Engineering Company, Inc.
All Rights Reserved

REVISIONS	CITY COMMENTS
4/6/06	

**ENGINEERING
PLANNING
SURVEYING**

221 Point West Blvd.
St. Charles, MO 63301
636-928-5552
FAX 928-1718

2-23-05	DATE
97-9203F	PROJECT NUMBER
2 OF 5	SHEET OF
9203FASB.DWG	FILE NAME
BGC	DRAWN
DRO	DESIGNED
CHECKED	CHECKED

AS-BUILTS ADDED FEBRUARY 2005

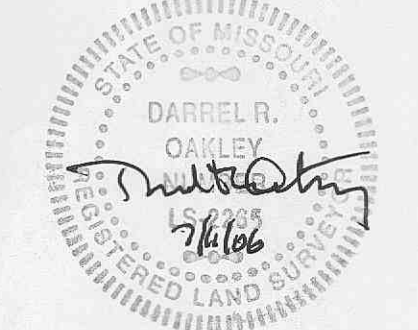

TOM GINNEVER ROAD

PROPERTY N/F
COOL SPRINGS VENTURE, L.L.C.
2796/1364

COOL SPRINGS ROAD

COOL SPRINGS ROAD
(AKA) TOM GINNEVER ROAD

COOL SPRINGS ROAD
(AKA) TOM GINNEVER ROAD

PROPERTY N/F
SUMMIT POINT L.C.
4285/1892

SEE RECORD PLAT AND
AS-BUILT PLANS FOR
"WILAS AT CRYSTAL RIDGE,
PLAT ONE"
P.B.40 PGS.232-233
DONE BY OTHERS

EXISTING 10' WIDE
SANITARY SEWER ESMT.
2243/1878

FORT ZUMWALT
SCHOOL DISTRICT R-2
BK.654 PG.41
919.49'

NOTE:
 ALL STORM SEWERS ARE PRIVATE EXCEPT WHERE NOTED OTHERWISE!

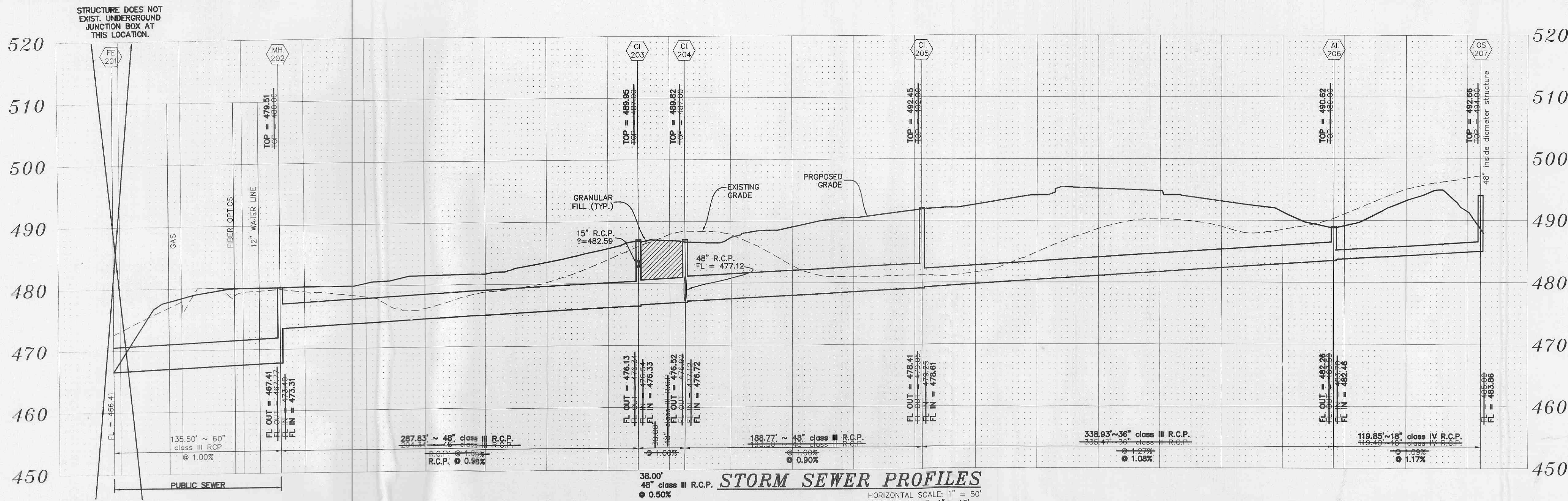

STORM SEWER PROFILES
 HORIZONTAL SCALE: 1" = 50'
 VERTICAL SCALE: 1" = 10'

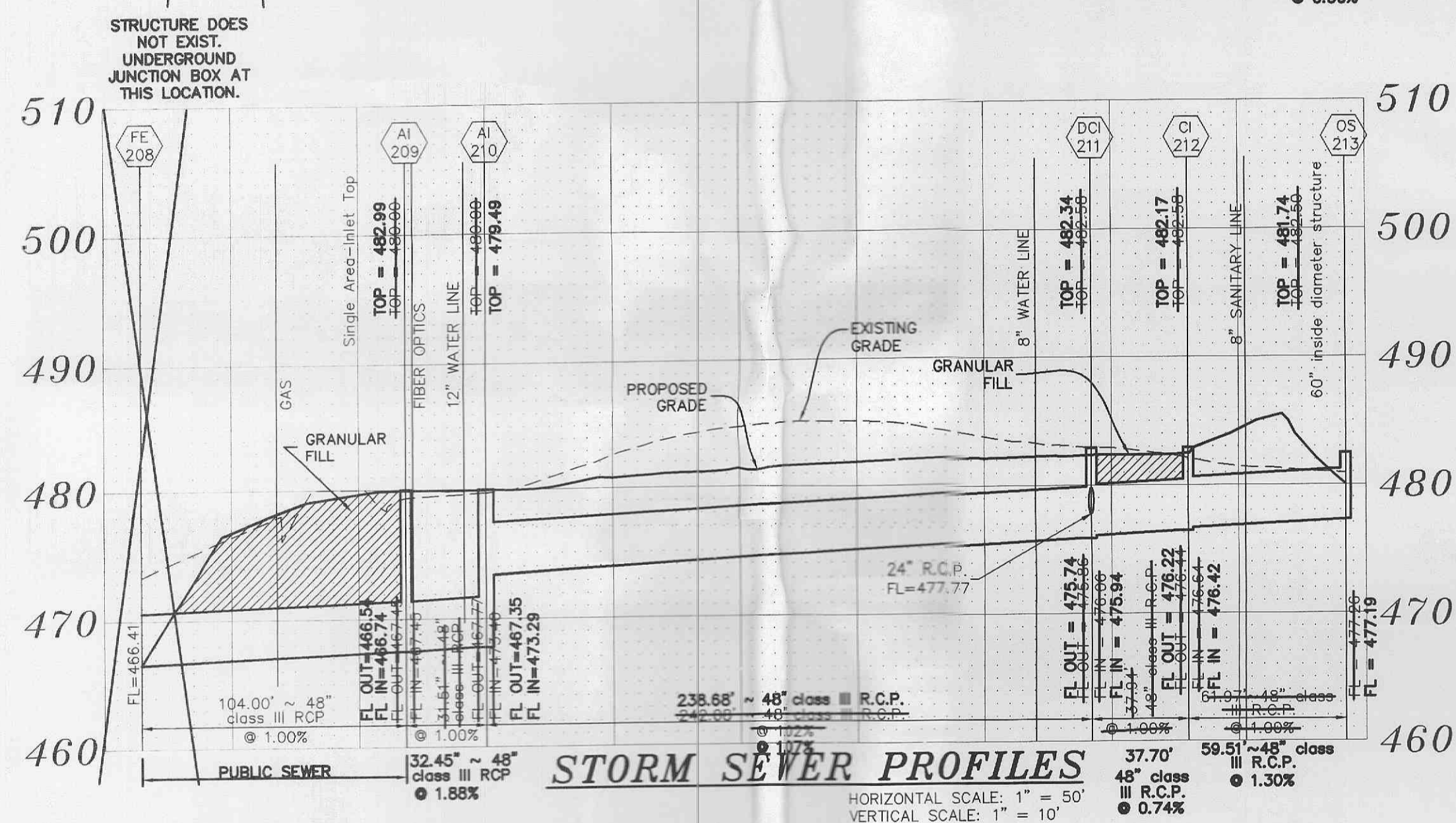

STORM SEWER PROFILES
 HORIZONTAL SCALE: 1" = 50'
 VERTICAL SCALE: 1" = 10'

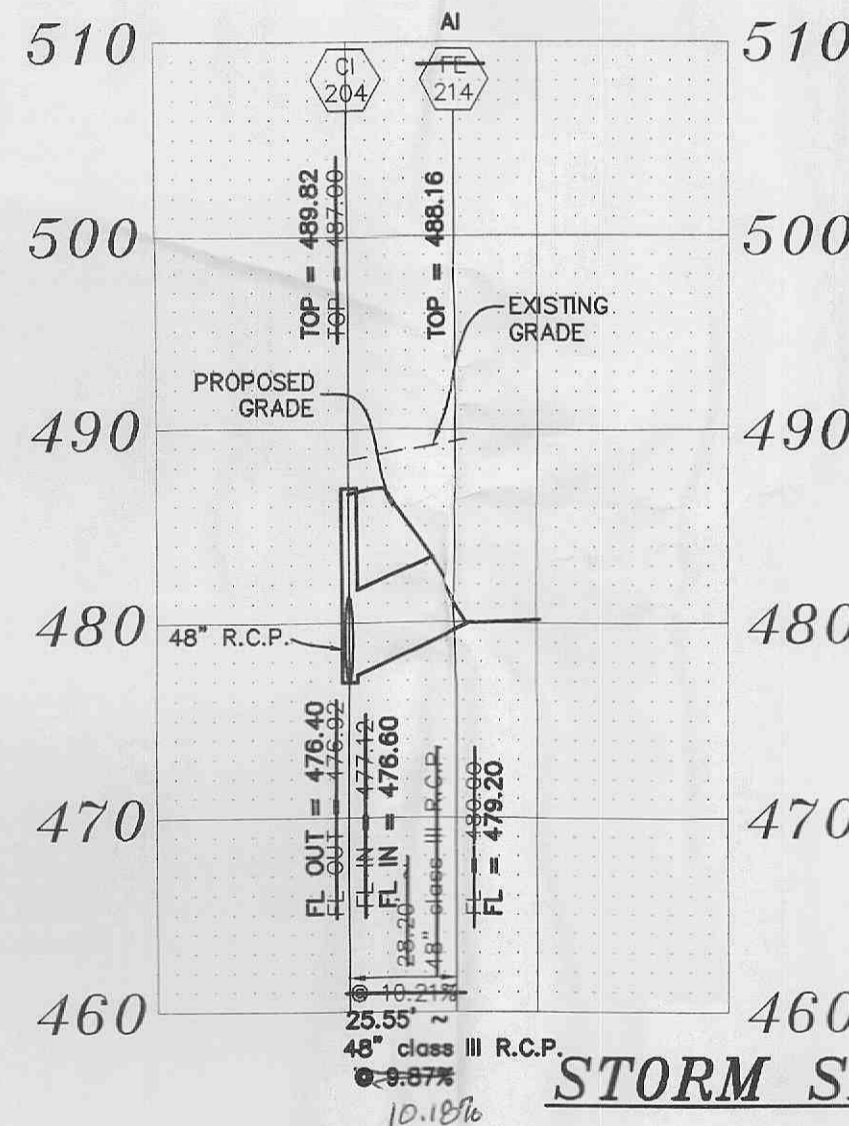

STORM SEWER PROFILES
 HORIZONTAL SCALE: 1" = 50'
 VERTICAL SCALE: 1" = 10'

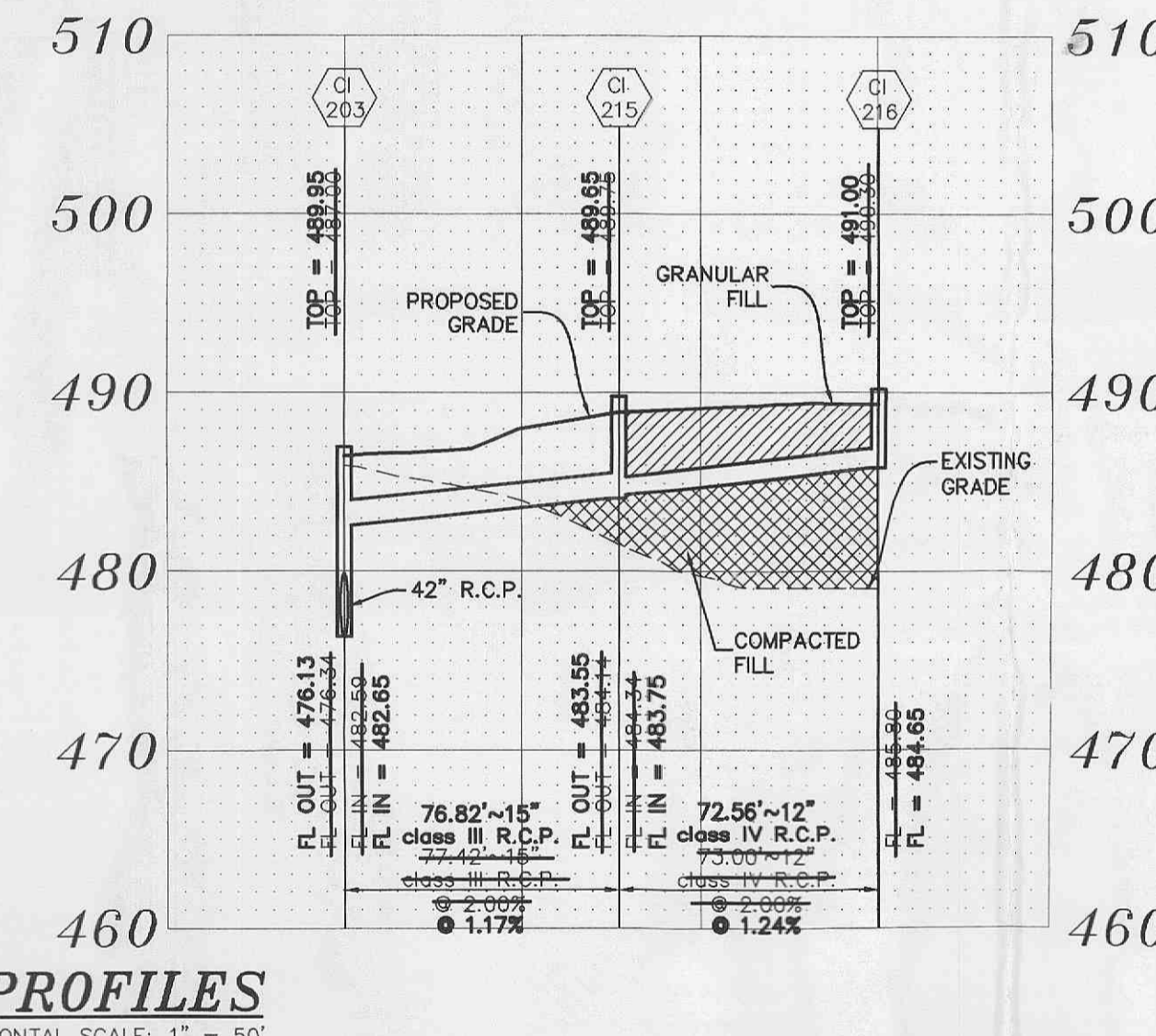

STORM SEWER PROFILES
 HORIZONTAL SCALE: 1" = 50'
 VERTICAL SCALE: 1" = 10'

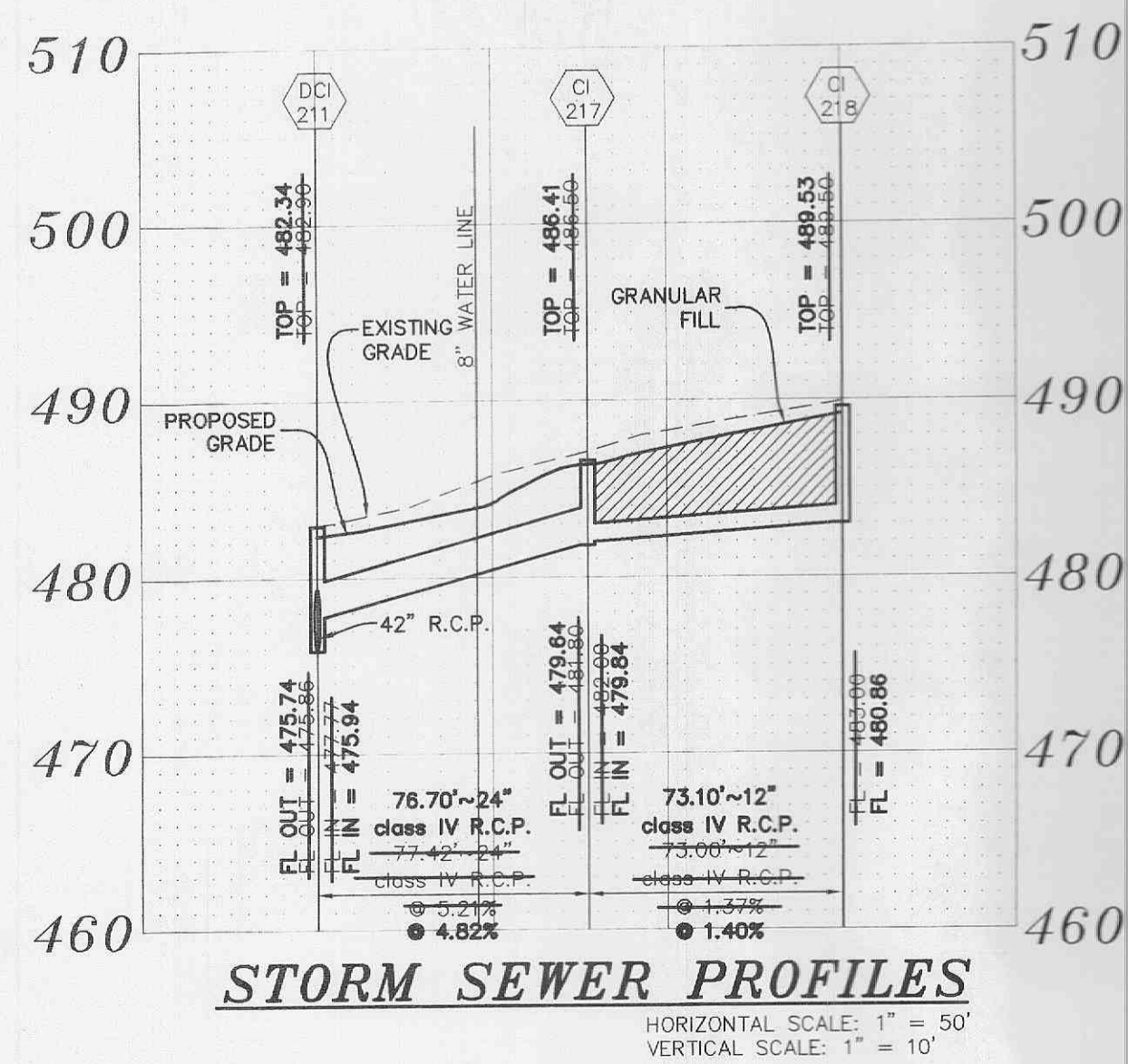

STORM SEWER PROFILES
 HORIZONTAL SCALE: 1" = 50'
 VERTICAL SCALE: 1" = 10'

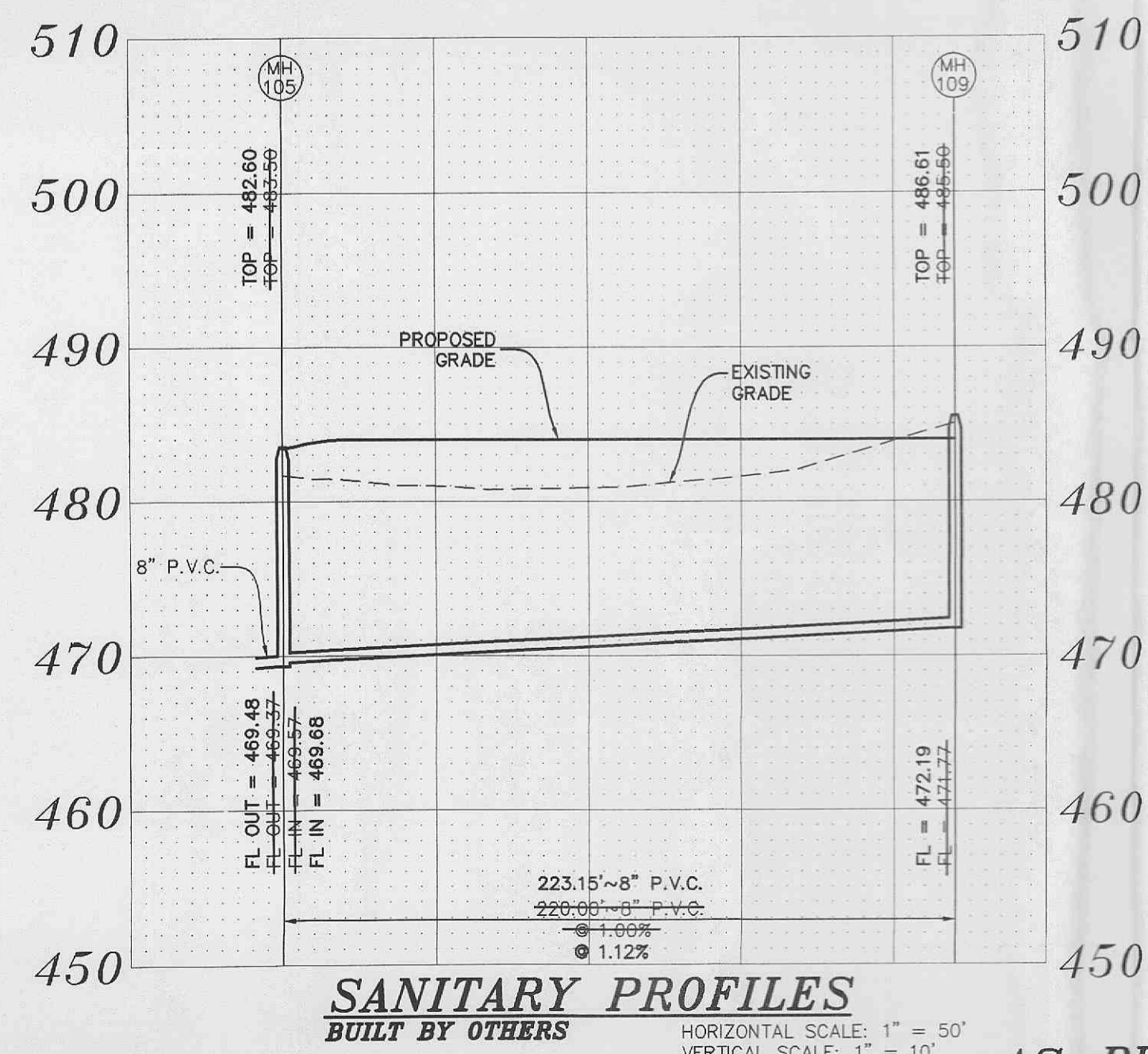

SANITARY PROFILES
 BUILT BY OTHERS
 HORIZONTAL SCALE: 1" = 50'
 VERTICAL SCALE: 1" = 10'

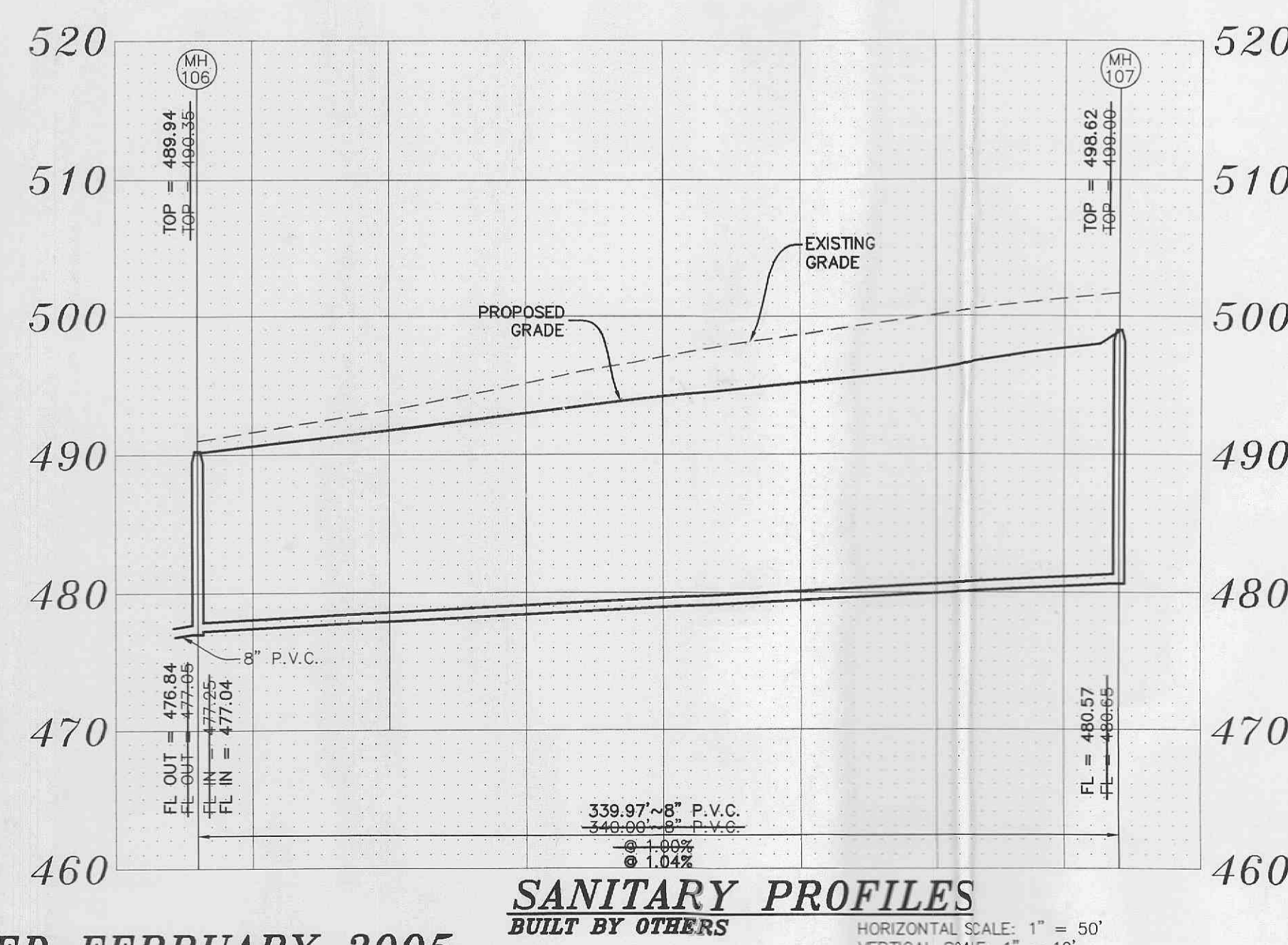

SANITARY PROFILES
 BUILT BY OTHERS
 HORIZONTAL SCALE: 1" = 50'
 VERTICAL SCALE: 1" = 10'

AS-BUILTS ADDED FEBRUARY 2005

ALL SANITARY SEWER LATERAL, TAILSTAKE ELEVATIONS HAVE BEEN DESIGNED FOR AN BASEMENT POUR IN HOMES WITH THE TOP OF FOUNDATION ELEVATION BEING SET A MINIMUM OF ABOVE THE TOP OF CURB ELEVATION AT THE DRIVEWAY.

UNDERGROUND UTILITIES HAVE BEEN PLOTTED FROM AVAILABLE INFORMATION AND THEREFORE THEIR LOCATIONS SHALL BE CONSIDERED APPROXIMATE ONLY. THE VERIFICATION OF THE LOCATION OF ALL UNDERGROUND UTILITIES, EITHER SHOWN OR NOT SHOWN ON THESE PLANS SHALL BE THE RESPONSIBILITY OF THE CONTRACTOR, AND SHALL BE LOCATED PRIOR TO ANY GRADING OR CONSTRUCTION OF THE IMPROVEMENTS.

SCALE: VERTICAL = 10
 HORIZONTAL = 50

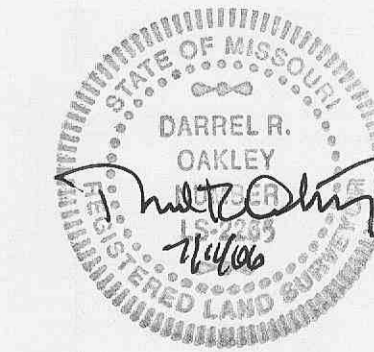

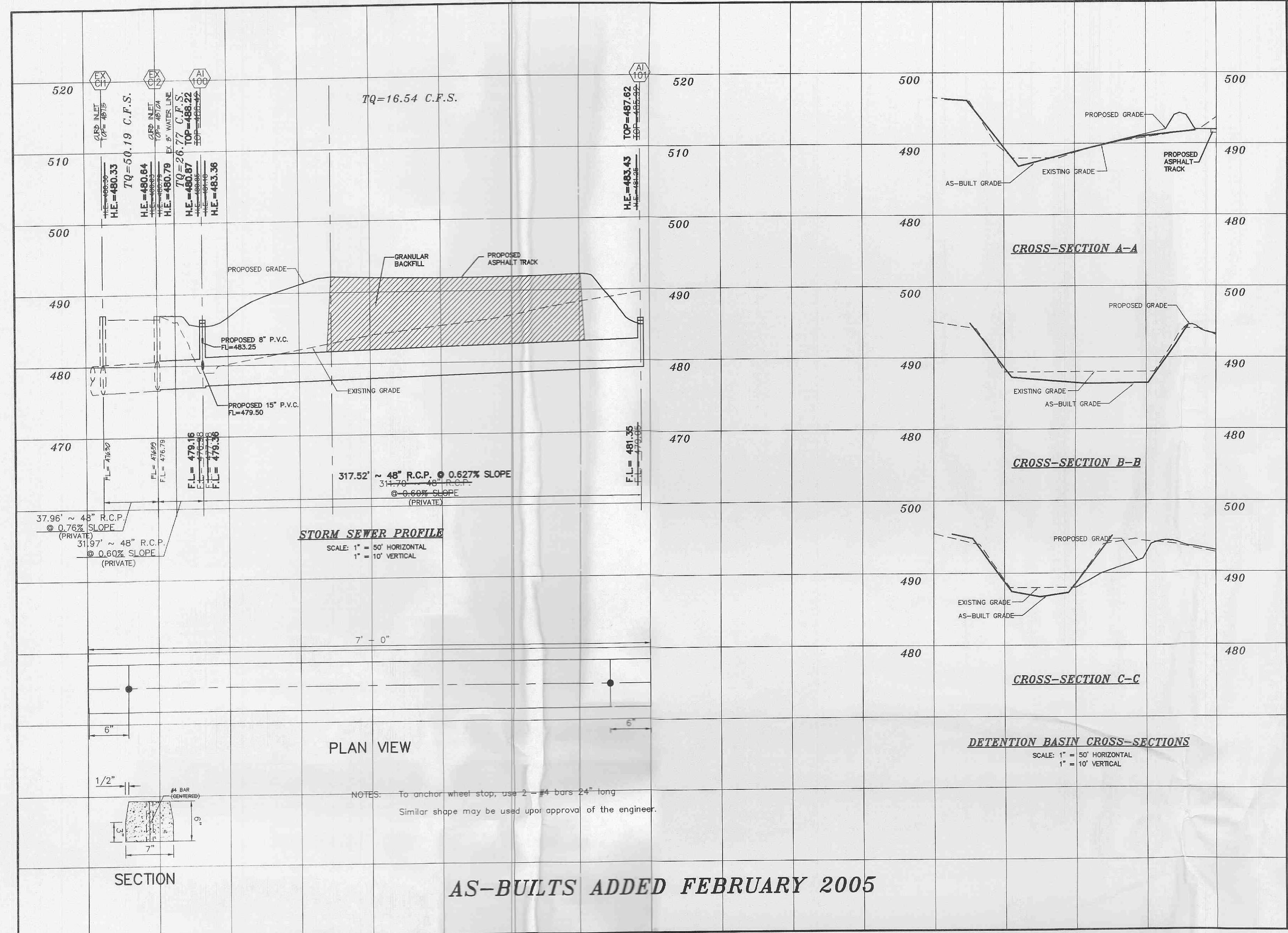

STORM SEWER PROFILE
 SCALE: 1" = 50' HORIZONTAL
 1" = 10' VERTICAL

CROSS-SECTION A-A

CROSS-SECTION B-B

CROSS-SECTION C-C

DETENTION BASIN CROSS-SECTIONS
 SCALE: 1" = 50' HORIZONTAL
 1" = 10' VERTICAL

PLAN VIEW

NOTES: To anchor wheel stop, use 2 #4 bars 24" long.
 Similar shape may be used upon approval of the engineer.

AS-BUILTS ADDED FEBRUARY 2005

BAX PROJECT NAME : LIVING WORD CHRISTIAN SCHOOL
 BAX PROJECT NO. : 97-9203F
 RUN DATE : 4-24-06
 RUN BY : ALJ
 FILENAME: 9203FE

UPP STR	LOW STR	L	DIA	UPPER FL LN	LOWER FL LN	PS	UPPER ST EL	DEPTH HY GR	UPPER HY EL	LOWER HY EL	HYDR GRADE	FR HEAD	VEL	VEL HEAD	JUNC LOSS	TURN LOSS	CURVE LOSS	STR GRADE	INL CAP	DR AREA	PI	Q	TQ	PIPE CAP	REMARKS	
CI 218 CI 217	73	12	480.86	479.84	1.40	489.53	7.90	481.63	180.84	.00750	0.55	3.92	0.24	0.24	0.00	0.00	0.00	0.00	0.00	0.00	0.00	0.00	3.08	4.21	1	
CI 217 DCI211	77	24	479.64	475.94	4.78	486.41	6.33	480.08*	178.11	.00040	0.03	1.43	0.03	0.00	0.09	0.00	0.00	0.00	0.00	0.00	0.00	0.00	4.50	49.46	2	
OS 213 CI 212	60	48	477.19	476.42	1.29	481.74	0.74	481.00	180.44	.00210	0.13	5.25	0.43	0.43	0.00	0.00	0.00	0.00	0.00	0.00	0.00	0.00	66.02	163.39	3	
CI 212 DCI211	38	48	476.22	475.94	0.74	482.17	1.73	480.44	179.94	.00210	0.08	5.27	0.43	0.21	0.21	0.00	0.00	0.00	0.00	0.00	0.00	0.00	66.25	123.79	4	
DCI211 AI 210	239	48	475.74	473.29	1.03	482.34	4.23	478.11	177.29	.00260	0.62	5.82	0.53	0.15	0.05	0.00	0.00	0.00	0.00	0.00	0.00	0.00	73.14	145.53	5	
AI 210 AI 209	32	48	467.35	466.74	1.88	479.49	8.48	471.01	170.74	.00280	0.09	6.07	0.57	0.12	0.06	0.00	0.00	0.00	0.00	0.00	0.00	0.00	76.32	196.95	6	
AI 209 FE 208	104	48	466.54	466.41	0.13	482.99	12.25	470.74	170.41	.00290	0.30	6.17	0.59	0.03	0.00	0.00	0.00	0.00	0.00	0.00	0.00	0.00	77.53	50.79	7	HW=470.41

* INDICATES CRITICAL DEPTH

BAX PROJECT NAME : LIVING WORD CHRISTIAN SCHOOL
 BAX PROJECT NO. : 97-9203F
 RUN DATE : 5-3-06
 RUN BY : ALJ
 FILENAME: 9203FW

UPP STR	LOW STR	L	DIA	UPPER FL LN	LOWER FL LN	PS	UPPER ST EL	DEPTH HY GR	UPPER HY EL	LOWER HY EL	HYDR GRADE	FR HEAD	VEL	VEL HEAD	JUNC LOSS	TURN LOSS	CURVE LOSS	STR GRADE	INL CAP	DR AREA	PI	Q	TQ	PIPE CAP	REMARKS		
AI 214 CI 204	26	48	479.20	476.60	10.18	488.16	7.54	480.62	480.60	.00010	0.00	1.15	0.02	0.02	0.00	0.00	0.00	0.00	0.00	0.00	0.00	0.00	0.00	14.43	458.22	1	
CI 216 CI 215	73	12	484.65	483.75	1.24	491.00	5.83	485.18*	484.75	.00360	0.26	2.74	0.12	0.12	0.00	0.00	0.00	0.00	0.00	0.00	0.00	0.00	2.15	3.97	2		
CI 215 CI 203	77	15	483.55	482.65	1.17	489.65	5.24	484.41	483.90	.00430	0.33	3.45	0.18	0.14	0.04	0.00	0.00	0.00	0.00	0.00	0.00	0.00	4.23	6.99	3		
OS 207 AI 206	120	18	483.86	482.46	1.17	492.66	7.10	485.56	483.96	.00920	1.10	5.69	0.50	0.50	0.00	0.00	0.00	0.00	0.00	0.00	0.00	0.00	10.05	11.35	4		
AI 206 CI 205	339	36	482.26	478.61	1.08	490.62	7.08	483.54*	481.61	.00150	0.52	3.70	0.21	0.02	0.00	0.00	0.00	0.00	0.00	0.00	0.00	0.00	26.14	69.22	5		
CI 205 CI 204	189	48	478.41	476.72	0.90	492.45	11.65	480.80	480.72	.00040	0.08	2.30	0.08	0.00	0.00	0.00	0.00	0.00	0.00	0.00	0.00	0.00	28.87	135.91	6		
CI 204 CI 203	38	48	476.52	476.33	0.50	489.82	9.23	480.59	480.33	.00090	0.03	3.46	0.19	0.17	0.06	0.00	0.00	0.00	0.00	0.00	0.00	0.00	43.53	101.57	7		
CI 203 MH 202	288	48	476.13	473.31	0.98	489.95	11.95	478.00	477.31	.00120	0.34	3.90	0.24	0.08	0.27	0.00	0.00	0.00	0.00	0.00	0.00	0.00	49.03	142.18	8		
MH 202 FE 201	136	60	467.41	466.41	0.74	479.51	7.85	471.66	471.41	.00040	0.05	2.50	0.10	0.03	0.17	0.00	0.00	0.00	0.00	0.00	0.00	0.00	49.03	223.74	9	HW=471.41	

* INDICATES CRITICAL DEPTH

BAX PROJECT NAME : LIVING WORD CHRISTIAN SCHOOL
 BAX PROJECT NO. : 97-9203F
 RUN DATE : 5-3-06
 RUN BY : ALJ
 FILENAME: 9203FW2

UPP STR	LOW STR	L	DIA	UPPER FL LN	LOWER FL LN	PS	UPPER ST EL	DEPTH HY GR	UPPER HY EL	LOWER HY EL	HYDR GRADE	FR HEAD	VEL	VEL HEAD	JUNC LOSS	TURN LOSS	CURVE LOSS	STR GRADE	INL CAP	DR AREA	PI	Q	TQ	PIPE CAP	REMARKS	
AI 101 AI 100	318	48	481.35	479.36	0.63	487.62	4.19	483.43	483.36	.00010	0.04	1.32	0.03	0.03	0.00	0.00	0.00	0.00	0.00	0.00	0.00	0.00	16.54	113.72	1	
AI 100 EX CI2	32	48	479.16	476.79	7.43	488.22	7.35	480.87	480.79	.00030	0.01	2.13	0.07	0.06	0.01	0.00	0.00	0.00	0.00	0.00	0.00	0.00	26.77	391.10	2	
EX CI2 EX CI1	38	48	476.59	476.30	0.76	487.04	6.40	480.64	480.33	.00120	0.05	3.99	0.25	0.23	0.03	0.00	0.00	0.00	0.00	0.00	0.00	0.00	50.19	125.55	3	HW=480.33

* INDICATES CRITICAL DEPTH



ALL SANITARY SEWER LATERAL TAILSTAKE ELEVATIONS HAVE BEEN DESIGNED FOR AN BASEMENT POUR IN HOMES WITH THE TOP OF FOUNDATION ELEVATION BEING SET A MINIMUM OF ABOVE THE TOP OF CURB ELEVATION AT THE DRIVEWAY.

UNDERGROUND UTILITIES HAVE BEEN PLOTTED FROM AVAILABLE INFORMATION AND THEREFORE THEIR LOCATIONS SHALL BE CONSIDERED APPROXIMATE ONLY. THE VERIFICATION OF THE LOCATION OF ALL UNDERGROUND UTILITIES, EITHER SHOWN OR NOT SHOWN ON THESE PLANS SHALL BE THE RESPONSIBILITY OF THE CONTRACTOR, AND SHALL BE LOCATED PRIOR TO ANY GRADING OR CONSTRUCTION OF THE IMPROVEMENTS.

SCALE: VERTICAL = 10
 HORIZONTAL = 50

5
 5

THIS SHEET IS FOR INFORMATIONAL PURPOSES ONLY AND IS NOT TO BE USED FOR CONSTRUCTION.

REVISIONS

02-21-03 CITY COMMENTS
06-16-03 CITY COMMENTS
08-18-03 CITY COMMENTS

GRAPHIC SCALE

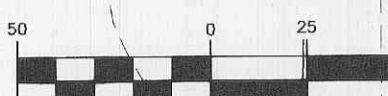

(IN FEET)
1 inch = 50 ft.

PROPERTY N/F
NOTHUM GROUP
I-1 ZONING

PROPERTY N/F
NOTHUM GROUP
R-4 P.U.D. ZONING

OFF-SITE
6.75 AC. @ 3.85 C.F.S./AC.
TQ = 25.99 C.F.S.

OFF-SITE
20.00 AC. @ 3.85 C.F.S./AC.
TQ = 88.81 C.F.S.

L=39.27'
R=25.00'

S87°47'23"E 1143.16'

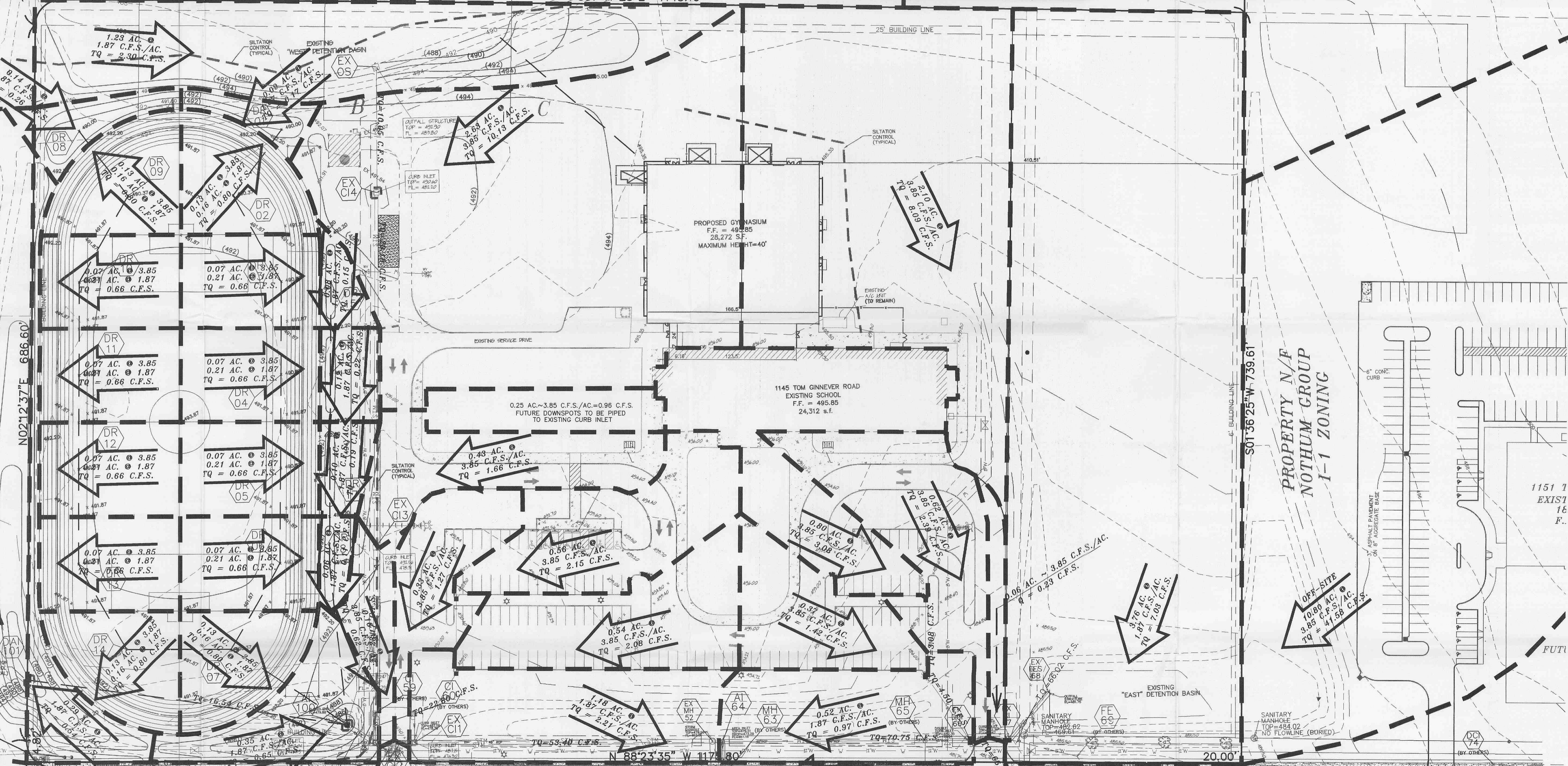

N02°12'37"E 686.60'

S01°36'25"W 739.61'

OFF-SITE
4.85 AC. @ 3.85 C.F.S./AC.
TQ = 18.60 C.F.S.

L=39.44'
R=25.00'

N 88°10'34" W 151.71'
N 01°49'26" E 14.51'

N 88°23'35" W 1171.80'

N 88°23'35" W 999.83'

COMMERCIAL USE
C-2 ZONING

TOM GINNEVER ROAD

OFF-SITE
10.80 AC. @ 3.85 C.F.S./AC.
TQ = 41.58 C.F.S.

1151 1
EXIST
16
F..