

CITY OF O'FALLON
 COMMUNITY DEVELOPMENT DEPARTMENT
 ACCEPTED FOR CONSTRUCTION
 BY: [Signature] DATE: Nov. 19, 2013
 PROFESSIONAL ENGINEER'S SEAL
 INDICATES RESPONSIBILITY FOR DESIGN

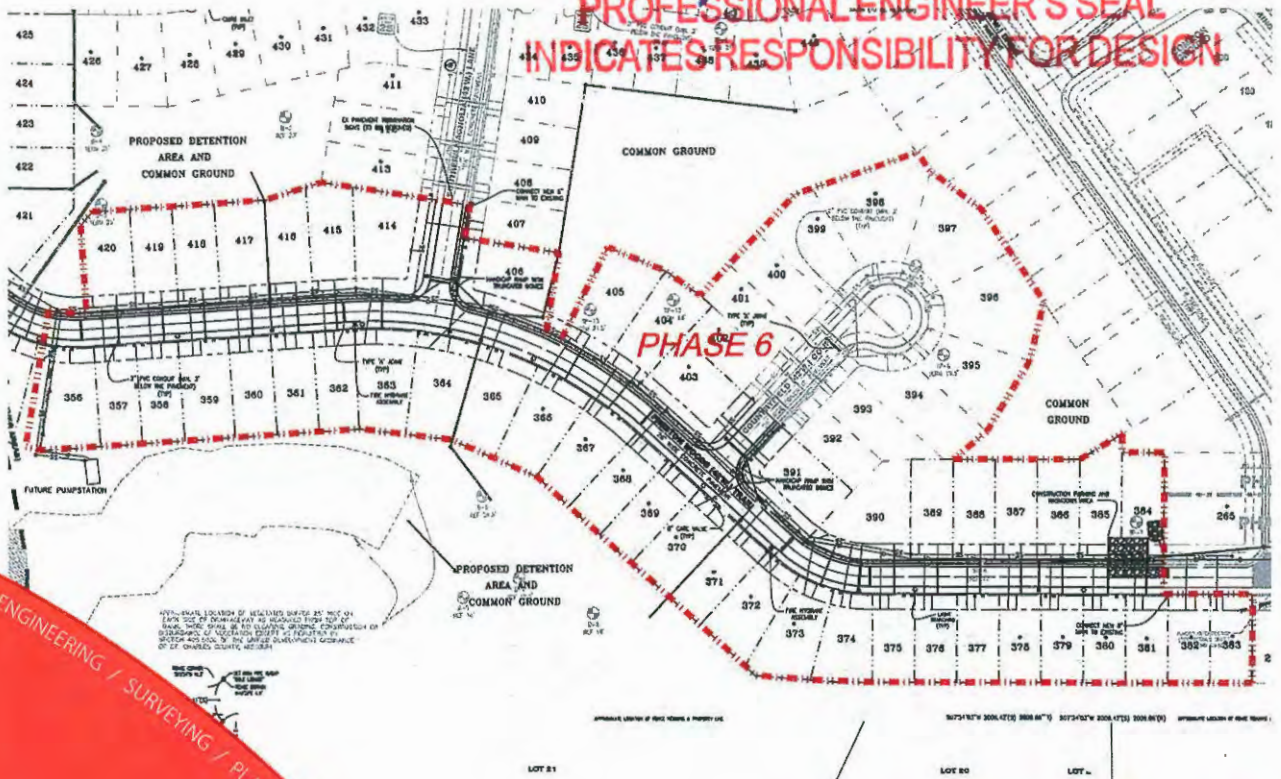

CIVIL ENGINEERING / SURVEYING / PLANNING / LANDSCAPE ARCHITECTURE

Preston Woods Phase 6 Detention Report

Pulte Group
 17107 Chesterfield Airport Road, Suite 120
 Chesterfield, Missouri 63005

September 10, 2013
 Project # 13-0054

cole

1520 S. Fifth Street
 Suite 307
 St. Charles, MO 63303
 636.978.7508 tel

CITY OF FALLON

COMMUNITY DEVELOPMENT DEPARTMENT

ACCEPTED FOR CONSTRUCTION

BY: _____ DATE: _____

PROFESSIONAL ENGINEER'S SEAL

INDICATES RESPONSIBILITY FOR DESIGN

TABLE OF CONTENTS

- I. STORM WATER MANAGEMENT SUMMARY
- II. EXHIBIT A – Soils Map
- III. EXHIBIT B – Existing Conditions – Drainage Map
- IV. EXHIBIT C – Existing Conditions Pondpack Report
- V. EXHIBIT D – Proposed Conditions – Drainage Map
- VI. EXHIBIT E – Detention Sections and Outlet Details
- VII. EXHIBIT F – Proposed Conditions – Pondpack Report

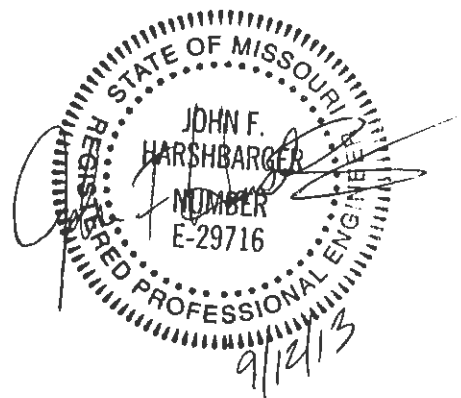

Faint, illegible text, possibly bleed-through from the reverse side of the page.



PURPOSE OF THE REPORT

The purpose of this report is to present the hydraulic analysis for the 2-year, 10-year, and 100-year, 24 hour storm events as required by St. Charles County, Missouri. The calculations for time of concentration, detention volume, rainfall discharge, and routing were performed using the computer software PondPack V8i, by Haested Methods.

METHOD OF ANALYSIS

The overall Preston Woods development site is approximately 168.5 acres is located at Highway N and Rhodes Road. Phases 1-5 of the subdivision have been constructed and detention is provided in two basins previously approved by the City. This report is to provide the detention analysis for the remaining phases of the development (approximately 60.1 acres) which discharge at the southeast corner of the development. The detention analysis is based on the St. Charles County Design Criteria Section 50.80. A summary of the requirements are listed below.

- For sites over 10 acres, the post development peak flow for the 2-year and 10-year 24 hour storms shall not exceed the existing peak flow for the respective storm event.
- The existing and post developed peak flows shall be determined using Technical Release 55 (TR-55) for sites 10 acres or greater.
- Detention basin volume will be based on routing the post-developed 2-year, 10-year, and 100-year 24 hour inflow hydrographs while satisfying the appropriate allowable release rates.
- The maximum depth of water in a dry detention basin shall not exceed six (6) feet.
- The maximum ponding elevation shall be calculated based on a routing of the 100-year 24 hour storm event for sites greater than 10 acres.
- A minimum of two (2) feet of freeboard shall be provided from the top of the basin to the maximum ponding elevation.

ANALYSIS SUMMARY

The original use of the site was a homestead used for raising livestock. The current usage of the land is undeveloped meadows and woods. The hydrologic soil types for the site is based on the Web Soil Survey by the Natural Resources Conservation Services. A copy of the soil map is provided in Exhibit A. A copy of the existing conditions, time of concentration route, and CN values used in the analysis is provided in Exhibit B. The site conditions were input into PondPack and routed to determine the allowable release rates for the site. A copy of the PondPack report is provided in Exhibit C.

The proposed use of the site is single family residential. Detention is being provided via two (2) detention basins. A copy of the proposed condition layout, time of concentration routing, and CN values is provided in Exhibit D. Detention is being provided in two Basins (noted as A and B) as shown in Exhibit D. The outfall structure for Basin A is a 6ft by 6ft riser structure with a 1.5ft wide by 1ft high low flow opening at elevation 562.0, a 4ft wide by 1ft high intermediate opening at elevation 565.75, and the top of the riser set at elevation 566.85. The outfall structure for Basin B is a 7ft by 7ft riser structure with a 3ft wide by 1ft high opening at elevation 541.00 and the top of the riser set at elevation 544.50. A copy of the basin sections and outlet structure details are provided in Exhibit E. The proposed site conditions were input into PondPack and routed to determine the proposed release rates from the site. A copy of the PondPack report is provided in Exhibit F.

SUMMARY OF RESULTS

Allowable Release Rate (Point of Interest)

2-yr Peak Discharge	=	42.88cfs @ 12.10 hours
10-yr Peak Discharge	=	119.79cfs @ 12.10 hours

Proposed Conditions:

Basin A:

2-yr Peak Discharge	=	11.64cfs @ 12.35 hours
2-yr High Water Elevation	=	564.60
10-yr Peak Discharge	=	15.04cfs @ 12.45 hours
10-yr High Water Elevation	=	566.34
100-yr Peak Discharge	=	92.62cfs @ 12.20 hours
100-yr High Water Elevation	=	567.73

Basin B:

2-yr Peak Discharge	=	22.40cfs @ 12.05 hours
2-yr High Water Elevation	=	544.36
10-yr Peak Discharge	=	68.99cfs @ 12.15 hours
10-yr High Water Elevation	=	545.22
100-yr Peak Discharge	=	124.75cfs @ 12.15 hours
100-yr High Water Elevation	=	546.07

Bypass Area:

2-yr Peak Discharge	=	7.95cfs @ 12.10 hours
10-yr Peak Discharge	=	22.70cfs @ 12.10 hours

Point of Interest:

2-yr Peak Discharge	=	40.36cfs @ 12.15 hours
10-yr Peak Discharge	=	103.30cfs @ 12.15 hours

As noted above, the post-development 2-year and 10-year, 24 hour peak discharges do not exceed the allowable release rates based on pre-developed conditions.

EXHIBIT A

SOILS MAP

Hydrologic Soil Group—St. Charles County, Missouri



































Map Scale: 1:3,880 if printed on A portrait (8.5" x 11") sheet.

0 50 100 200 300 Meters

0 150 300 600 900 Feet

Map projection: Web Mercator Corner coordinates: WGS84 Edge tics: UTM Zone 15N WGS84

MAP LEGEND

- Area of Interest (AOI)**
 -  Area of Interest (AOI)
- Soils**
 - Soil Rating Polygons**
 -  A
 -  A/D
 -  B
 -  B/D
 -  C
 -  C/D
 -  D
 -  Not rated or not available
 - Soil Rating Lines**
 -  A
 -  A/D
 -  B
 -  B/D
 -  C
 -  C/D
 -  D
 -  Not rated or not available
 - Soil Rating Points**
 -  A
 -  A/D
 -  B
 -  B/D
-  C
-  C/D
-  D
-  Not rated or not available
- Water Features**
 -  Streams and Canals
- Transportation**
 -  Rails
 -  Interstate Highways
 -  US Routes
 -  Major Roads
 -  Local Roads
- Background**
 -  Aerial Photography

MAP INFORMATION

The soil surveys that comprise your AOI were mapped at 1:24,000.

Warning: Soil Map may not be valid at this scale.

Enlargement of maps beyond the scale of mapping can cause misunderstanding of the detail of mapping and accuracy of soil line placement. The maps do not show the small areas of contrasting soils that could have been shown at a more detailed scale.

Please rely on the bar scale on each map sheet for map measurements.

Source of Map: Natural Resources Conservation Service
 Web Soil Survey URL: <http://websoilsurvey.nrcs.usda.gov>
 Coordinate System: Web Mercator (EPSG:3857)

Maps from the Web Soil Survey are based on the Web Mercator projection, which preserves direction and shape but distorts distance and area. A projection that preserves area, such as the Albers equal-area conic projection, should be used if more accurate calculations of distance or area are required.

This product is generated from the USDA-NRCS certified data as of the version date(s) listed below.

Soil Survey Area: St. Charles County, Missouri
 Survey Area Data: Version 11, Sep 24, 2012

Soil map units are labeled (as space allows) for map scales 1:50,000 or larger.

Date(s) aerial images were photographed: Oct 1, 2010—Mar 9, 2012

The orthophoto or other base map on which the soil lines were compiled and digitized probably differs from the background imagery displayed on these maps. As a result, some minor shifting of map unit boundaries may be evident.

Hydrologic Soil Group

Hydrologic Soil Group— Summary by Map Unit — St. Charles County, Missouri (MO183)				
Map unit symbol	Map unit name	Rating	Acres in AOI	Percent of AOI
60086	Crider silt loam, 9 to 14 percent slopes, eroded	C	21.6	45.5%
60112	Goss gravelly silt loam, 14 to 45 percent slopes	C	4.0	8.4%
60260	Weller silt loam, 5 to 9 percent slopes	D	3.1	6.5%
66004	Dockery silt loam, 0 to 2 percent slopes, frequently flooded	B/D	2.7	5.6%
66029	Dockery silt loam, 0 to 2 percent slopes, occasionally flooded	B/D	16.2	34.0%
Totals for Area of Interest			47.5	100.0%

Description

Hydrologic soil groups are based on estimates of runoff potential. Soils are assigned to one of four groups according to the rate of water infiltration when the soils are not protected by vegetation, are thoroughly wet, and receive precipitation from long-duration storms.

The soils in the United States are assigned to four groups (A, B, C, and D) and three dual classes (A/D, B/D, and C/D). The groups are defined as follows:

Group A. Soils having a high infiltration rate (low runoff potential) when thoroughly wet. These consist mainly of deep, well drained to excessively drained sands or gravelly sands. These soils have a high rate of water transmission.

Group B. Soils having a moderate infiltration rate when thoroughly wet. These consist chiefly of moderately deep or deep, moderately well drained or well drained soils that have moderately fine texture to moderately coarse texture. These soils have a moderate rate of water transmission.

Group C. Soils having a slow infiltration rate when thoroughly wet. These consist chiefly of soils having a layer that impedes the downward movement of water or soils of moderately fine texture or fine texture. These soils have a slow rate of water transmission.

Group D. Soils having a very slow infiltration rate (high runoff potential) when thoroughly wet. These consist chiefly of clays that have a high shrink-swell potential, soils that have a high water table, soils that have a claypan or clay layer at or near the surface, and soils that are shallow over nearly impervious material. These soils have a very slow rate of water transmission.

If a soil is assigned to a dual hydrologic group (A/D, B/D, or C/D), the first letter is for drained areas and the second is for undrained areas. Only the soils that in their natural condition are in group D are assigned to dual classes.

Rating Options

Aggregation Method: Dominant Condition

Component Percent Cutoff: None Specified

Tie-break Rule: Higher

EXHIBIT B

EXISTING CONDITIONS – DRAINAGE MAP

US22, Topo Sheet 146, PRE, IDW
 DATE: September 12, 2013 - 11:13:01 PM
 DRAWING: S:\WORK\13-0054\CD-2013\13-0054_CD-2013.dwg

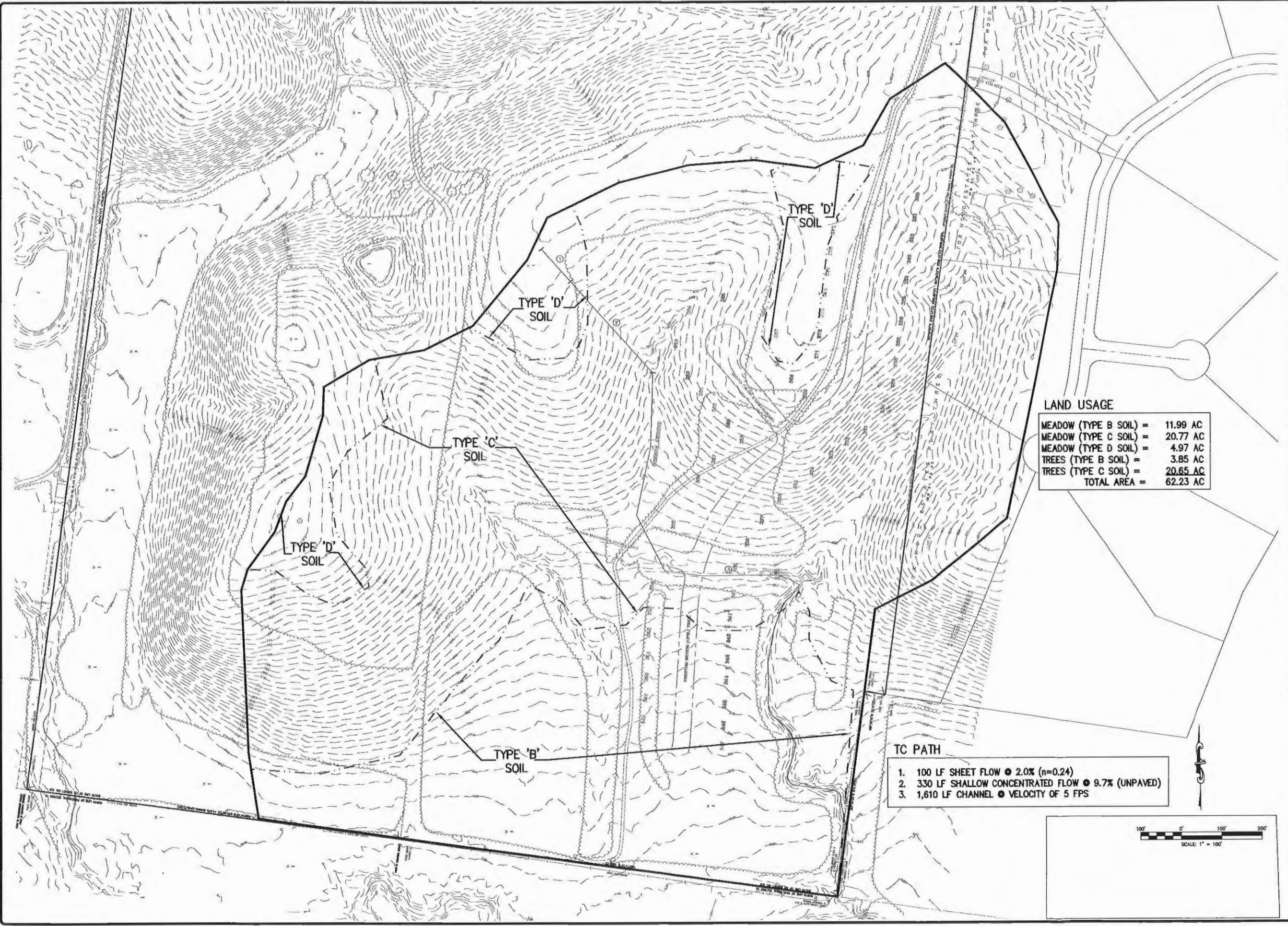

LAND USAGE

MEADOW (TYPE B SOIL) =	11.99 AC
MEADOW (TYPE C SOIL) =	20.77 AC
MEADOW (TYPE D SOIL) =	4.97 AC
TREES (TYPE B SOIL) =	3.85 AC
TREES (TYPE C SOIL) =	20.65 AC
TOTAL AREA =	62.23 AC

- TC PATH**
- 100 LF SHEET FLOW @ 2.0% (n=0.24)
 - 330 LF SHALLOW CONCENTRATED FLOW @ 9.7% (UNPAVED)
 - 1,610 LF CHANNEL @ VELOCITY OF 5 FPS

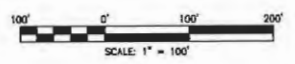

<p>DEVELOPER/OWNER: FILTE GROUP 16640 CHESTERFIELD GROVE STE 200 CHESTERFIELD, MO 63005 PHONE: (636) 537-7129</p>		<p>DATE: 9/12/2013 CITY COMMAND: 1 CITY COMMAND: 2</p>
<p>PRESTON WOODS PHASE 6 MASS GRADING PLANS PRESTON WOODS LANE OF FALLON, MO 63366</p>		<p>NO. REVISION DESCRIPTION</p>
<p>ST. CHARLES 1320 S. Fifth Street Suite 307 St. Charles, MO 63001 635.707.7581 fax</p> <p>cole CIVIL ENGINEERING / SURVEYING / PLANNING / LANDSCAPE ARCHITECTURE Cole & Associates, Inc.</p>		<p>DATE: 9/12/2013 Job Number: 13-0054 Sheet Number: EXA</p>
<p>DESIGN/CALC BY: JFH DRAWN BY: MTS CHECKED BY: JFH DRAWING SCALE: - DATE: 9/12/2013</p>		<p>NO. REVISION DESCRIPTION</p>
<p>PRE DEVELOPMENT DAM</p>		<p>NO. REVISION DESCRIPTION</p>

EXHIBIT C

EXISTING CONDITIONS – PONDPACK REPORT

PROPOSED 10YR STORM EVENT ROUTING

Project Summary

Title	PRESTON WOODS PHASE 6 DETENTION REPORT
Engineer Company	Cole & Associates
Date	8/21/2013

Notes	EXISTING CONDITIONS
-------	---------------------

Table of Contents

	User Notifications	2
	Master Network Summary	3
Existing Conditions	Time of Concentration Calculations, 2 years	4
Existing Conditions	Runoff CN-Area, 2 years	6
	Unit Hydrograph Equations	7
Existing Conditions		
	Unit Hydrograph Summary, 2 years	9
	Unit Hydrograph (Hydrograph Table), 2 years	11
	Unit Hydrograph Summary, 10 years	13
	Unit Hydrograph (Hydrograph Table), 10 years	15

PROPOSED 10YR STORM EVENT ROUTING

Subsection: User Notifications

User Notifications?	No user notifications generated.
---------------------	----------------------------------

PROPOSED 10YR STORM EVENT ROUTING

Subsection: Master Network Summary

Catchments Summary

Label	Scenario	Return Event (years)	Hydrograph Volume (ft ³)	Time to Peak (hours)	Peak Flow (ft ³ /s)
Existing Conditions	St. Charles County - Synthetic Curve, 2 yrs	2	191,864.000	12.100	42.88
Existing Conditions	St. Charles County - Synthetic Curve, 10 yrs	10	422,637.000	12.100	119.79

Node Summary

Label	Scenario	Return Event (years)	Hydrograph Volume (ft ³)	Time to Peak (hours)	Peak Flow (ft ³ /s)
POI	St. Charles County - Synthetic Curve, 2 yrs	2	191,864.000	12.100	42.88
POI	St. Charles County - Synthetic Curve, 10 yrs	10	422,637.000	12.100	119.79

PROPOSED 10YR STORM EVENT ROUTING

Subsection: Time of Concentration Calculations
Label: Existing Conditions

Return Event: 2 years
Storm Event: TypeII 24hr (3.25 in)

Time of Concentration Results

Segment #1: TR-55 Sheet Flow	
Hydraulic Length	100.00 ft
Manning's n	0.240
Slope	0.020 ft/ft
2 Year 24 Hour Depth	3.3 in
Average Velocity	0.12 ft/s
Segment Time of Concentration	0.236 hours

Segment #2: TR-55 Shallow Concentrated Flow	
Hydraulic Length	330.00 ft
Is Paved?	False
Slope	0.097 ft/ft
Average Velocity	5.03 ft/s
Segment Time of Concentration	0.018 hours

Segment #3: Length and Velocity	
Hydraulic Length	1,610.00 ft
Velocity	5.00 ft/s
Segment Time of Concentration	0.089 hours

Time of Concentration (Composite)	
Time of Concentration (Composite)	0.344 hours

PROPOSED 10YR STORM EVENT ROUTING

Subsection: Time of Concentration Calculations
Label: Existing Conditions

Return Event: 2 years
Storm Event: TypeII 24hr (3.25 in)

==== User Defined Length & Velocity

Tc = $(L_f / V) / 3600$
Tc= Time of concentration, hours
Where: Lf= Flow length, feet
V= Velocity, ft/sec

==== SCS Channel Flow

$R = Q_a / W_p$
Tc = $V = (1.49 * (R^{2/3}) * (S_f^{0.5})) / n$
 $(L_f / V) / 3600$
R= Hydraulic radius
Aq= Flow area, square feet
Wp= Wetted perimeter, feet
Where: V= Velocity, ft/sec
Sf= Slope, ft/ft
n= Manning's n
Tc= Time of concentration, hours
Lf= Flow length, feet

==== SCS TR-55 Shallow Concentration Flow

Unpaved surface:
V = $16.1345 * (S_f^{0.5})$
Tc = Paved Surface:
V = $20.3282 * (S_f^{0.5})$
 $(L_f / V) / 3600$
Where: V= Velocity, ft/sec
Sf= Slope, ft/ft
Tc= Time of concentration, hours
Lf= Flow length, feet

PROPOSED 10YR STORM EVENT ROUTING

Subsection: Runoff CN-Area
 Label: Existing Conditions

Return Event: 2 years
 Storm Event: TypeII 24hr (3.25 in)

Runoff Curve Number Data

Soil/Surface Description	CN	Area (acres)	C (%)	UC (%)	Adjusted CN
Meadow - cont. grass (non grazed) - ---- - Soil C	71.000	20.770	0.0	0.0	71.000
Woods - good - Soil C	70.000	20.650	0.0	0.0	70.000
Meadow - cont. grass (non grazed) - ---- - Soil B	58.000	11.990	0.0	0.0	58.000
Meadow - cont. grass (non grazed) - ---- - Soil D	78.000	4.970	0.0	0.0	78.000
Woods - good - Soil B	55.000	3.850	0.0	0.0	55.000
COMPOSITE AREA & WEIGHTED CN --->	(N/A)	62.230	(N/A)	(N/A)	67.733

PROPOSED 10YR STORM EVENT ROUTING

Subsection: Unit Hydrograph Equations

Unit Hydrograph Method (Computational Notes)

Definition of Terms

At	Total area (acres): $A_t = A_i + A_p$
Ai	Impervious area (acres)
Ap	Pervious area (acres)
CNI	Runoff curve number for impervious area
CNp	Runoff curve number for pervious area
fLoss	f loss constant infiltration (depth/time)
gKs	Saturated Hydraulic Conductivity (depth/time)
Md	Volumetric Moisture Deficit
Psi	Capillary Suction (length)
hK	Horton Infiltration Decay Rate (time^{-1})
fo	Initial Infiltration Rate (depth/time)
fc	Ultimate(capacity)Infiltration Rate (depth/time)
Ia	Initial Abstraction (length)
dt	Computational increment (duration of unit excess rainfall) Default dt is smallest value of $0.1333T_c$, r_{tm} , and t_h (Smallest dt is then adjusted to match up with T_p)
UDdt	User specified override computational main time increment (only used if UDdt is $\Rightarrow .1333T_c$)
D(t)	Point on distribution curve (fraction of P) for time step t
K	$2 / (1 + (T_r/T_p))$: default $K = 0.75$: (for $T_r/T_p = 1.67$) Hydrograph shape factor = Unit Conversions * $K = ((1\text{hr}/3600\text{sec}) * (1\text{ft}/12\text{in}) * ((5280\text{ft})^2/\text{sq.mi})) * K$ Default $K_s = 645.333 * 0.75 = 484$
Ks	
Lag	Lag time from center of excess runoff (dt) to T_p : $\text{Lag} = 0.6T_c$
P	Total precipitation depth, inches
Pa(t)	Accumulated rainfall at time step t
Pi(t)	Incremental rainfall at time step t
qp	Peak discharge (cfs) for 1in. runoff, for 1hr, for 1 sq.mi. = $(K_s * A * Q) / T_p$ (where $Q = 1\text{in. runoff}$, $A = \text{sq.mi.}$)
Qu(t)	Unit hydrograph ordinate (cfs) at time step t
Q(t)	Final hydrograph ordinate (cfs) at time step t
Rai(t)	Accumulated runoff (inches) at time step t for impervious area
Rap(t)	Accumulated runoff (inches) at time step t for pervious area
Rii(t)	Incremental runoff (inches) at time step t for impervious area
Rip(t)	Incremental runoff (inches) at time step t for pervious area
R(t)	Incremental weighted total runoff (inches)
Rtm	Time increment for rainfall table
Si	S for impervious area: $S_i = (1000/CNI) - 10$
Sp	S for pervious area: $S_p = (1000/CNp) - 10$
t	Time step (row) number
Tc	Time of concentration
Tb	Time (hrs) of entire unit hydrograph: $T_b = T_p + T_r$
Tp	Time (hrs) to peak of a unit hydrograph: $T_p = (dt/2) + \text{Lag}$
Tr	Time (hrs) of receding limb of unit hydrograph: $T_r = \text{ratio of } T_p$

PROPOSED 10YR STORM EVENT ROUTING

Subsection: Unit Hydrograph Equations

Unit Hydrograph Method

Computational Notes

Precipitation

Column (1)	Time for time step t
Column (2)	$D(t)$ = Point on distribution curve for time step t
Column (3)	$P_i(t) = P_a(t) - P_a(t-1)$: Col.(4) - Preceding Col.(4)
Column (4)	$P_a(t) = D(t) \times P$: Col.(2) \times P

Pervious Area Runoff (using SCS Runoff CN Method)

Column (5)	$Rap(t)$ = Accumulated pervious runoff for time step t If $(P_a(t))$ is $\leq 0.2Sp$ then use: $Rap(t) = 0.0$ If $(P_a(t))$ is $> 0.2Sp$ then use: $Rap(t) = (Col.(4) - 0.2Sp)^2 / (Col.(4) + 0.8Sp)$
Column (6)	$Rip(t)$ = Incremental pervious runoff for time step t $Rip(t) = Rap(t) - Rap(t-1)$ $Rip(t) = Col.(5)$ for current row - $Col.(5)$ for preceding row.

Impervious Area Runoff

Column (7 & 8)... Did not specify to use impervious areas.

Incremental Weighted Runoff

Column (9)	$R(t) = (A_p/A_t) \times Rip(t) + (A_i/A_t) \times R_{ii}(t)$ $R(t) = (A_p/A_t) \times Col.(6) + (A_i/A_t) \times Col.(8)$
------------	---

SCS Unit Hydrograph Method

Column (10) $Q(t)$ is computed with the SCS unit hydrograph method using $R(t)$ and $Qu(t)$.

PROPOSED 10YR STORM EVENT ROUTING

Subsection: Unit Hydrograph Summary
 Label: Existing Conditions

Return Event: 2 years
 Storm Event: TypeII 24hr (3.25 in)

Storm Event	TypeII 24hr (3.25 in)
Return Event	2 years
Duration	35.000 hours
Depth	3.4 in
Time of Concentration (Composite)	0.344 hours
Area (User Defined)	62.230 acres
<hr/>	
Computational Time Increment	0.046 hours
Time to Peak (Computed)	12.144 hours
Flow (Peak, Computed)	43.12 ft ³ /s
Output Increment	0.050 hours
Time to Flow (Peak Interpolated Output)	12.100 hours
Flow (Peak Interpolated Output)	42.88 ft ³ /s
<hr/>	
Drainage Area	
SCS CN (Composite)	68.000
Area (User Defined)	62.230 acres
Maximum Retention (Pervious)	4.7 in
Maximum Retention (Pervious, 20 percent)	0.9 in
<hr/>	
Cumulative Runoff	
Cumulative Runoff Depth (Pervious)	0.8 in
Runoff Volume (Pervious)	191,550.466 ft ³
<hr/>	
Hydrograph Volume (Area under Hydrograph curve)	
Volume	191,864.000 ft ³
<hr/>	
SCS Unit Hydrograph Parameters	
Time of Concentration (Composite)	0.344 hours
Computational Time Increment	0.046 hours
Unit Hydrograph Shape Factor	483.432
K Factor	0.749
Receding/Rising, Tr/Tp	1.670

PROPOSED 10YR STORM EVENT ROUTING

Subsection: Unit Hydrograph Summary

Return Event: 2 years

Label: Existing Conditions

Storm Event: TypeII 24hr (3.25 in)

SCS Unit Hydrograph Parameters	
Unit peak, qp	205.16 ft ³ /s
Unit peak time, Tp	0.229 hours
Unit receding limb, Tr	0.916 hours
Total unit time, Tb	1.146 hours

PROPOSED 10YR STORM EVENT ROUTING

Subsection: Unit Hydrograph (Hydrograph Table)
 Label: Existing Conditions

Return Event: 2 years
 Storm Event: TypeII 24hr (3.25 in)

Storm Event	TypeII 24hr (3.25 in)
Return Event	2 years
Duration	35.000 hours
Depth	3.4 in
Time of Concentration (Composite)	0.344 hours
Area (User Defined)	62.230 acres

HYDROGRAPH ORDINATES (ft³/s)

Output Time Increment = 0.050 hours

Time on left represents time for first value in each row.

Time (hours)	Flow (ft ³ /s)	Flow (ft ³ /s)	Flow (ft ³ /s)	Flow (ft ³ /s)	Flow (ft ³ /s)
11.500	0.00	0.00	0.02	0.14	0.50
11.750	1.36	3.13	6.46	12.06	20.12
12.000	29.63	38.03	42.88	42.65	38.61
12.250	33.00	27.45	22.88	19.50	16.95
12.500	14.90	13.22	11.82	10.66	9.71
12.750	8.94	8.32	7.82	7.40	7.04
13.000	6.73	6.45	6.21	6.01	5.82
13.250	5.65	5.49	5.35	5.22	5.09
13.500	4.97	4.86	4.74	4.63	4.53
13.750	4.43	4.33	4.24	4.15	4.06
14.000	3.97	3.89	3.81	3.73	3.66
14.250	3.60	3.55	3.51	3.47	3.43
14.500	3.40	3.37	3.34	3.31	3.28
14.750	3.25	3.22	3.19	3.16	3.14
15.000	3.11	3.08	3.05	3.02	2.99
15.250	2.96	2.93	2.90	2.87	2.84
15.500	2.81	2.78	2.75	2.72	2.69
15.750	2.66	2.63	2.59	2.56	2.53
16.000	2.50	2.47	2.44	2.41	2.38
16.250	2.36	2.34	2.32	2.31	2.29
16.500	2.28	2.27	2.26	2.25	2.24
16.750	2.23	2.22	2.21	2.20	2.18
17.000	2.17	2.16	2.15	2.14	2.13
17.250	2.12	2.11	2.10	2.09	2.08
17.500	2.07	2.05	2.04	2.03	2.02
17.750	2.01	2.00	1.99	1.98	1.96
18.000	1.95	1.94	1.93	1.92	1.91
18.250	1.90	1.88	1.87	1.86	1.85
18.500	1.84	1.83	1.81	1.80	1.79
18.750	1.78	1.77	1.75	1.74	1.73
19.000	1.72	1.71	1.69	1.68	1.67
19.250	1.66	1.65	1.63	1.62	1.61

PROPOSED 10YR STORM EVENT ROUTING

Subsection: Unit Hydrograph (Hydrograph Table)
 Label: Existing Conditions

Return Event: 2 years
 Storm Event: TypeII 24hr (3.25 in)

HYDROGRAPH ORDINATES (ft³/s) Output Time Increment = 0.050 hours

Time on left represents time for first value in each row.

Time (hours)	Flow (ft ³ /s)	Flow (ft ³ /s)	Flow (ft ³ /s)	Flow (ft ³ /s)	Flow (ft ³ /s)
19.500	1.60	1.58	1.57	1.56	1.55
19.750	1.53	1.52	1.51	1.50	1.48
20.000	1.47	1.46	1.45	1.44	1.43
20.250	1.42	1.41	1.41	1.40	1.40
20.500	1.40	1.39	1.39	1.39	1.39
20.750	1.38	1.38	1.38	1.38	1.38
21.000	1.37	1.37	1.37	1.37	1.37
21.250	1.36	1.36	1.36	1.36	1.36
21.500	1.35	1.35	1.35	1.35	1.35
21.750	1.34	1.34	1.34	1.34	1.34
22.000	1.33	1.33	1.33	1.33	1.33
22.250	1.32	1.32	1.32	1.32	1.31
22.500	1.31	1.31	1.31	1.31	1.30
22.750	1.30	1.30	1.30	1.30	1.29
23.000	1.29	1.29	1.29	1.28	1.28
23.250	1.28	1.28	1.28	1.27	1.27
23.500	1.27	1.27	1.26	1.26	1.26
23.750	1.26	1.26	1.25	1.45	2.64
24.000	5.87	11.07	16.15	18.38	17.25
24.250	14.19	10.40	7.17	4.99	3.51
24.500	2.46	1.72	1.20	0.83	0.58
24.750	0.41	0.29	0.20	0.14	0.10
25.000	0.06	0.02	0.00	0.00	(N/A)

PROPOSED 10YR STORM EVENT ROUTING

Subsection: Unit Hydrograph Summary
 Label: Existing Conditions

Return Event: 10 years
 Storm Event: TypeII 24hr (5.0 in)

Storm Event	TypeII 24hr (5.0 in)
Return Event	10 years
Duration	24.000 hours
Depth	5.0 in
Time of Concentration (Composite)	0.344 hours
Area (User Defined)	62.230 acres
<hr/>	
Computational Time Increment	0.046 hours
Time to Peak (Computed)	12.098 hours
Flow (Peak, Computed)	119.95 ft ³ /s
Output Increment	0.050 hours
Time to Flow (Peak Interpolated Output)	12.100 hours
Flow (Peak Interpolated Output)	119.79 ft ³ /s
<hr/>	
Drainage Area	
SCS CN (Composite)	68.000
Area (User Defined)	62.230 acres
Maximum Retention (Pervious)	4.7 in
Maximum Retention (Pervious, 20 percent)	0.9 in
<hr/>	
Cumulative Runoff	
Cumulative Runoff Depth (Pervious)	1.9 in
Runoff Volume (Pervious)	424,589.658 ft ³
<hr/>	
Hydrograph Volume (Area under Hydrograph curve)	
Volume	422,637.000 ft ³
<hr/>	
SCS Unit Hydrograph Parameters	
Time of Concentration (Composite)	0.344 hours
Computational Time Increment	0.046 hours
Unit Hydrograph Shape Factor	483.432
K Factor	0.749
Receding/Rising, Tr/Tp	1.670

PROPOSED 10YR STORM EVENT ROUTING

Subsection: Unit Hydrograph Summary
Label: Existing Conditions

Return Event: 10 years
Storm Event: TypeII 24hr (5.0 in)

SCS Unit Hydrograph Parameters	
Unit peak, qp	205.16 ft ³ /s
Unit peak time, Tp	0.229 hours
Unit receding limb, Tr	0.916 hours
Total unit time, Tb	1.146 hours

PROPOSED 10YR STORM EVENT ROUTING

Subsection: Unit Hydrograph (Hydrograph Table)
 Label: Existing Conditions

Return Event: 10 years
 Storm Event: TypeII 24hr (5.0 in)

Storm Event	TypeII 24hr (5.0 in)
Return Event	10 years
Duration	24.000 hours
Depth	5.0 in
Time of Concentration (Composite)	0.344 hours
Area (User Defined)	62.230 acres

HYDROGRAPH ORDINATES (ft³/s)

Output Time Increment = 0.050 hours

Time on left represents time for first value in each row.

Time (hours)	Flow (ft ³ /s)	Flow (ft ³ /s)	Flow (ft ³ /s)	Flow (ft ³ /s)	Flow (ft ³ /s)
10.200	0.00	0.00	0.01	0.02	0.05
10.450	0.09	0.14	0.20	0.27	0.35
10.700	0.44	0.53	0.64	0.76	0.88
10.950	1.02	1.16	1.32	1.49	1.68
11.200	1.90	2.15	2.43	2.74	3.08
11.450	3.46	3.88	4.45	5.39	7.14
11.700	10.15	15.06	22.57	33.93	50.35
11.950	71.51	94.18	112.03	119.79	114.94
12.200	101.36	84.88	69.43	56.93	47.76
12.450	40.88	35.43	31.05	27.46	24.53
12.700	22.16	20.25	18.72	17.49	16.47
12.950	15.60	14.85	14.20	13.63	13.15
13.200	12.71	12.32	11.96	11.64	11.33
13.450	11.04	10.77	10.50	10.24	9.99
13.700	9.75	9.52	9.30	9.09	8.89
13.950	8.69	8.50	8.31	8.12	7.95
14.200	7.80	7.67	7.55	7.45	7.36
14.450	7.28	7.20	7.13	7.06	6.99
14.700	6.93	6.86	6.80	6.73	6.67
14.950	6.60	6.54	6.47	6.41	6.34
15.200	6.28	6.21	6.14	6.08	6.01
15.450	5.95	5.88	5.81	5.74	5.68
15.700	5.61	5.54	5.47	5.40	5.34
15.950	5.27	5.20	5.13	5.06	5.00
16.200	4.94	4.89	4.85	4.81	4.78
16.450	4.75	4.72	4.70	4.67	4.65
16.700	4.62	4.60	4.58	4.55	4.53
16.950	4.50	4.48	4.46	4.43	4.41
17.200	4.39	4.36	4.34	4.31	4.29
17.450	4.27	4.24	4.22	4.19	4.17
17.700	4.14	4.12	4.10	4.07	4.05
17.950	4.02	4.00	3.97	3.95	3.92

PROPOSED 10YR STORM EVENT ROUTING

Subsection: Unit Hydrograph (Hydrograph Table)
 Label: Existing Conditions

Return Event: 10 years
 Storm Event: TypeII 24hr (5.0 in)

HYDROGRAPH ORDINATES (ft³/s) Output Time Increment = 0.050 hours

Time on left represents time for first value in each row.

Time (hours)	Flow (ft ³ /s)	Flow (ft ³ /s)	Flow (ft ³ /s)	Flow (ft ³ /s)	Flow (ft ³ /s)
18.200	3.90	3.87	3.85	3.82	3.80
18.450	3.77	3.75	3.72	3.70	3.67
18.700	3.65	3.62	3.60	3.57	3.55
18.950	3.52	3.50	3.47	3.44	3.42
19.200	3.39	3.37	3.34	3.32	3.29
19.450	3.26	3.24	3.21	3.19	3.16
19.700	3.14	3.11	3.08	3.06	3.03
19.950	3.01	2.98	2.95	2.93	2.91
20.200	2.89	2.87	2.85	2.84	2.83
20.450	2.83	2.82	2.81	2.81	2.80
20.700	2.80	2.79	2.79	2.78	2.78
20.950	2.77	2.77	2.76	2.76	2.76
21.200	2.75	2.75	2.74	2.74	2.73
21.450	2.73	2.72	2.72	2.71	2.71
21.700	2.70	2.70	2.70	2.69	2.69
21.950	2.68	2.68	2.67	2.67	2.66
22.200	2.66	2.65	2.65	2.64	2.64
22.450	2.63	2.63	2.62	2.62	2.61
22.700	2.61	2.60	2.60	2.60	2.59
22.950	2.59	2.58	2.58	2.57	2.57
23.200	2.56	2.56	2.55	2.55	2.54
23.450	2.54	2.53	2.53	2.52	2.52
23.700	2.51	2.51	2.50	2.50	2.49
23.950	2.49	2.48	(N/A)	(N/A)	(N/A)

PROPOSED 10YR STORM EVENT ROUTING

Index

E

Existing Conditions (Runoff CN-Area, 2 years)...6

Existing Conditions (Time of Concentration Calculations, 2 years)...4, 5

Existing Conditions (Unit Hydrograph (Hydrograph Table), 10 years)...15, 16

Existing Conditions (Unit Hydrograph (Hydrograph Table), 2 years)...11, 12

Existing Conditions (Unit Hydrograph Summary, 10 years)...13, 14

Existing Conditions (Unit Hydrograph Summary, 2 years)...9, 10

M

Master Network Summary...3

U

Unit Hydrograph Equations...7, 8

User Notifications...2

EXHIBIT D

PROPOSED CONDITION – DRAINAGE MAP

EXHIBIT E

DETENTION SECTIONS AND OUTFALL DETAILS

TC PATHS

- BASIN A:**
- 100 LF SHEET FLOW @ 3.0% (n=0.24)
 - 65 LF SHALLOW CONCENTRATED FLOW @ 26.6% (UNPAVED)
 - 270 LF SHALLOW CONCENTRATED FLOW @ 5.2% (UNPAVED)
 - 83 LF 21" RCP @ 0.6%
 - 67 LF 21" RCP @ 2.0%
 - 35 LF 24" RCP @ 2.0%
 - 220 LF 24" RCP @ 0.6%

- BASIN B:**
- 100 LF SHEET FLOW @ 2.0% (n=0.24)
 - 180 LF SHALLOW CONCENTRATED FLOW @ 3.0% (UNPAVED)
 - 145 LF 12" RCP @ 1.0%
 - 465 LF 18" RCP @ 2.0%
 - 370 LF 24" RCP @ 5.0%
 - 220 LF 30" RCP @ 1.0%

- BYPASS AREA:**
- 120 LF SHEET FLOW @ 2.0% (n=0.24)
 - 203 LF SHALLOW CONCENTRATED FLOW @ 2.0% (PAVED)
 - 120 LF 18" RCP @ 1.0%
 - 180 LF 48" RCP @ 0.5%

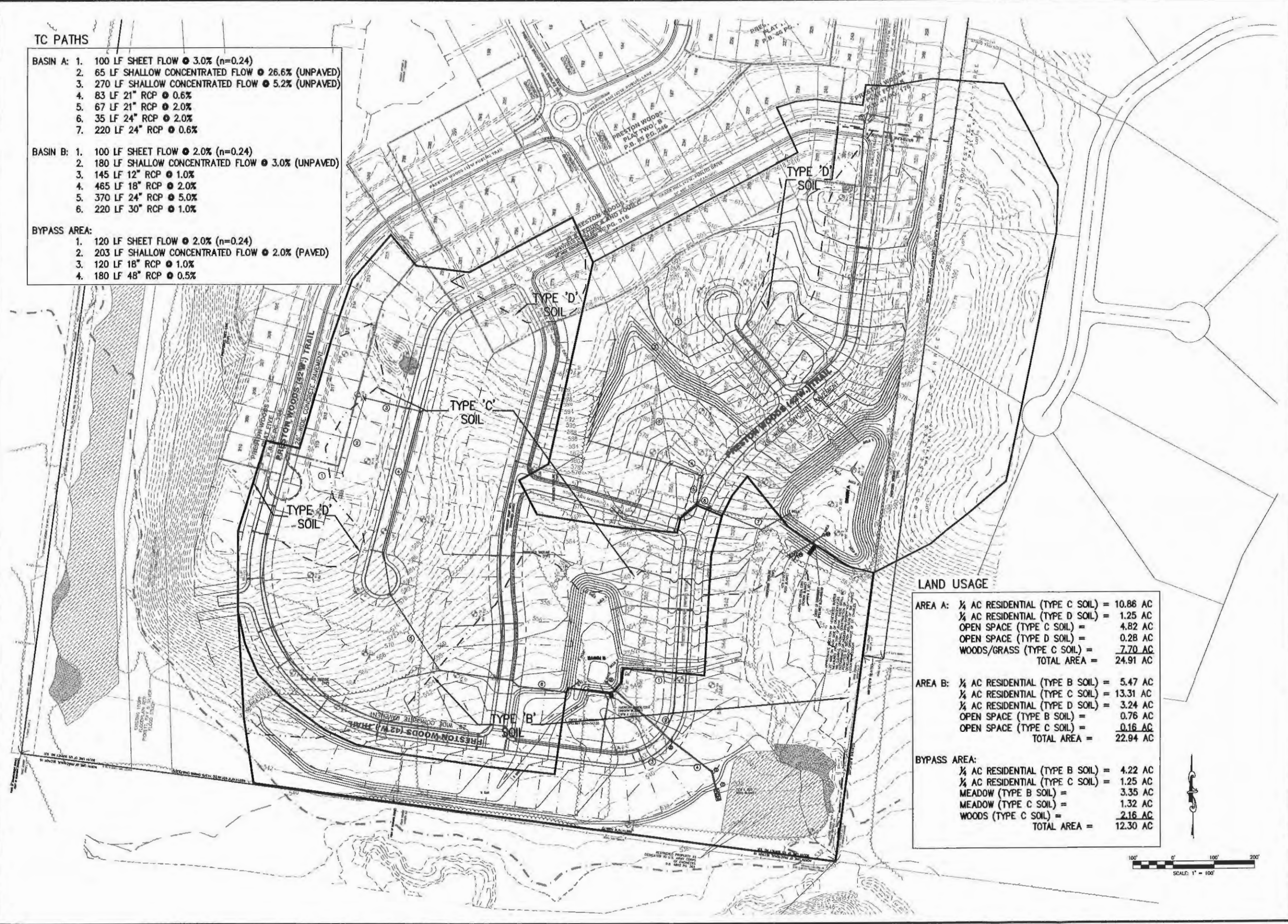

LAND USAGE

AREA A:	¼ AC RESIDENTIAL (TYPE C SOIL) = 10.86 AC
	¼ AC RESIDENTIAL (TYPE D SOIL) = 1.25 AC
	OPEN SPACE (TYPE C SOIL) = 4.82 AC
	OPEN SPACE (TYPE D SOIL) = 0.28 AC
	WOODS/GRASS (TYPE C SOIL) = 7.70 AC
	TOTAL AREA = 24.91 AC
AREA B:	¼ AC RESIDENTIAL (TYPE B SOIL) = 5.47 AC
	¼ AC RESIDENTIAL (TYPE C SOIL) = 13.31 AC
	¼ AC RESIDENTIAL (TYPE D SOIL) = 3.24 AC
	OPEN SPACE (TYPE B SOIL) = 0.76 AC
	OPEN SPACE (TYPE C SOIL) = 0.16 AC
	TOTAL AREA = 22.94 AC
BYPASS AREA:	¼ AC RESIDENTIAL (TYPE B SOIL) = 4.22 AC
	¼ AC RESIDENTIAL (TYPE C SOIL) = 1.25 AC
	MEADOW (TYPE B SOIL) = 3.35 AC
	MEADOW (TYPE C SOIL) = 1.32 AC
	WOODS (TYPE C SOIL) = 2.16 AC
	TOTAL AREA = 12.30 AC

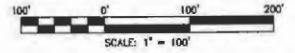

USER: Taylor Sheet 146: ULTIMATE DAM
 DATE: September 12, 2013 - 1:06:45 PM
 DRAWING: S:\V\2013\13-0054\13-0054\13-0054.dwg, C:\Users\jphillips\Documents\13-0054.dwg

<p>DEVELOPER/OWNER: PULTE GROUP 16640 CHESTERFIELD GROVE STE 200 CHESTERFIELD, MO 63005 PHONE: (636) 537-7129</p>	<p>DATE: 9/12/2013 CITY COMMENTS: NO REVISION DESCRIPTION</p>
<p>PRESTON WOODS PHASE 6 MASS GRADING PLANS PRESTON WOODS LANE O'FALLON, MO 63066</p>	
<p>ULTIMATE DAM</p>	
<p>+ ST. CHARLES 1320 S. Fifth Street Suite 307 St. Charles, MO 63070 636.272.5818</p>	
<p>cole CIVIL ENGINEERING / SURVEYING / PLANNING / LANDSCAPE ARCHITECTURE Cole & Associates, Inc.</p>	
<p>DESIGN/CALC BY: JFH DRAWN BY: MTS CHECKED BY: JFH DRAWING SCALE:</p>	
<p>DATE: 9/12/2013 Job Number 13-0054 Sheet Number EXB</p>	

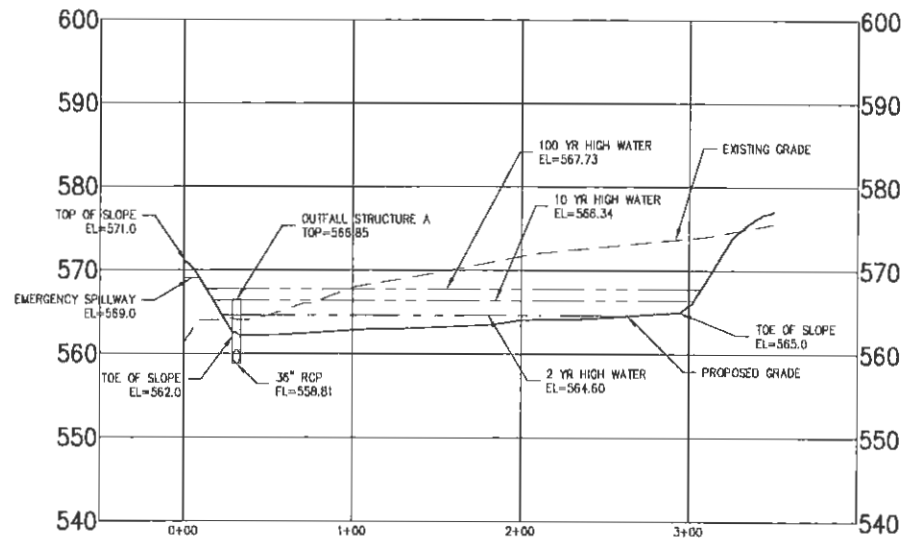

5 DETENTION BASIN A A-A
SCALE: REF. DWG.

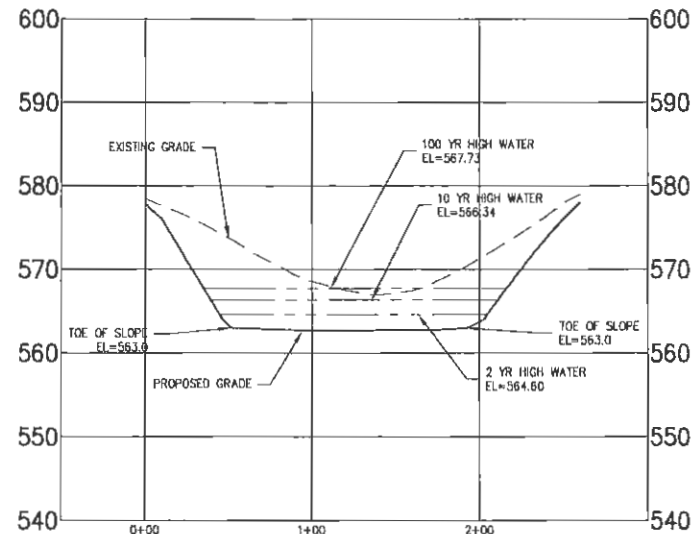

4 DETENTION BASIN A B-B
SCALE: REF. DWG.

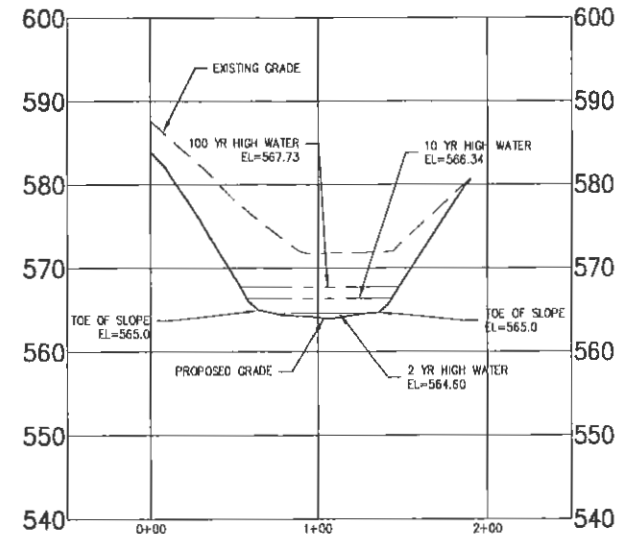

3 DETENTION BASIN A C-C
SCALE: REF. DWG.

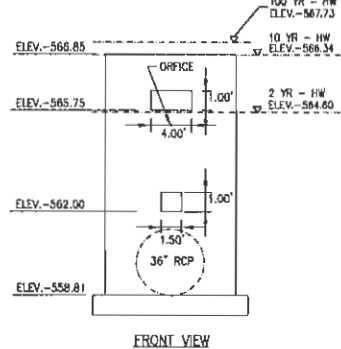
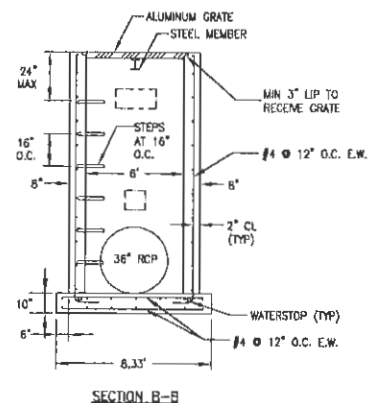
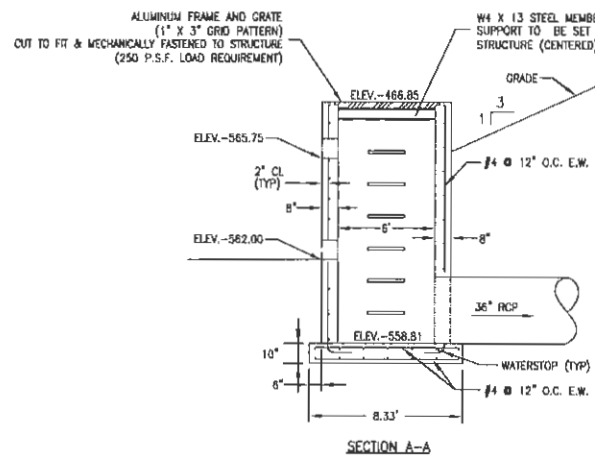
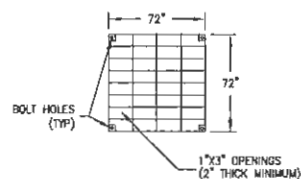
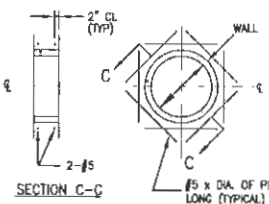
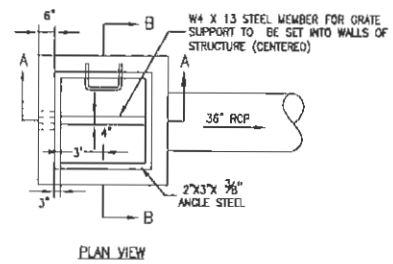

NOTE:
CONTRACTOR TO PROVIDE SIGNED AND SEALED SHOP DRAWINGS TO BE APPROVED BY THE PROJECT ENGINEER AND CITY OF O'FALLON.

1 OVERFLOW STRUCTURE A DETAIL
SCALE: 1"=50' HORIZ. 1"=10' VERT. REF. DWG.

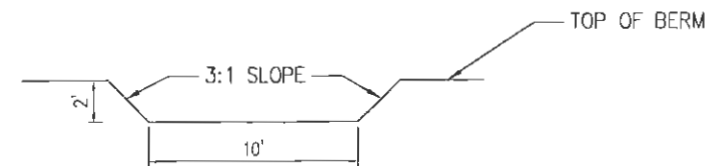

6 EMERGENCY SPILLWAY DETAIL
SCALE: REF. DWG.

PREPARED BY: ST. CHARLES ENGINEERING ARCHITECTURE
 1501 S. O'FALLON AVENUE, SUITE 307
 O'FALLON, ILLINOIS 62450-1201
 PHONE: (618) 233-7229
 FAX: (618) 233-7230
 WWW: WWW.SCAEARCH.COM

NO.	DATE	DESCRIPTION
1	08/29/2013	CITY COMMENTS
2	08/29/2013	CITY COMMENTS
3	07/11/2013	CITY COMMENTS
4		
5		

DEVELOPER/OWNER:
PLITE GROUP
 16640 CHESTERFIELD GROVE STE 200
 CHESTERFIELD, MO 63005
 PHONE: (636) 537-7129

THE PROFESSIONAL ENGINEER'S SEAL AND SIGNATURE ARE REQUIRED FOR ANY APPROVAL OF THIS PLAN. ANY CHANGES TO SECTION 202, 411 (REV. 04/10) ARE THE RESPONSIBILITY OF ALL OTHER PARTS. THE PROFESSIONAL ENGINEER'S SEAL AND SIGNATURE ARE REQUIRED FOR ANY APPROVAL OF THIS PLAN. ANY CHANGES TO SECTION 202, 411 (REV. 04/10) ARE THE RESPONSIBILITY OF ALL OTHER PARTS. THE PROFESSIONAL ENGINEER'S SEAL AND SIGNATURE ARE REQUIRED FOR ANY APPROVAL OF THIS PLAN. ANY CHANGES TO SECTION 202, 411 (REV. 04/10) ARE THE RESPONSIBILITY OF ALL OTHER PARTS.

PRESTON WOODS
 PHASE 6
 MASS GRADING PLANS
 O'FALLON, MO 62450
 DATE: 07/11/2013
 DRAWN BY: ELLIS

BASIN A CROSS SECTIONS

ST. CHARLES ENGINEERING ARCHITECTURE
 1501 S. O'FALLON AVENUE, SUITE 307
 O'FALLON, MO 62450
 PHONE: (618) 233-7229
 FAX: (618) 233-7230
 WWW: WWW.SCAEARCH.COM

cole
 CIVIL ENGINEERING / SURVIVING / PLANNING / LANDSCAPE ARCHITECTURE
 Cole & Associates, Inc.

DESIGN/DWG BY	MTS
DRAWN BY	MTS
CHECKED BY	JFH
DRAWING SCALE	
DATE	09/04/2013
Job Number	13-0054
Sheet Number	C8.10

EXHIBIT F

PROPOSED CONDITIONS – PONDPACK REPORT

PROPOSED CONDITIONS

Project Summary

Title	PRESTON WOODS PHASE 6 DETENTION REPORT
Engineer	Cole & Associates
Company	
Date	8/12/2013

Notes	PROPOSED CONDITIONS
-------	---------------------

Table of Contents

	User Notifications	2
	Master Network Summary	5
St. Charles County		
	Time-Depth Curve, 2 years	8
	Time-Depth Curve, 10 years	10
	Time-Depth Curve, 100 years	12
Area A		
	Time of Concentration Calculations, 2 years	14
Area B		
	Time of Concentration Calculations, 2 years	17
BY-PASS		
	Time of Concentration Calculations, 2 years	20
Area A		
	Runoff CN-Area, 2 years	22
Area B		
	Runoff CN-Area, 2 years	23
BY-PASS		
	Runoff CN-Area, 2 years	24
	Unit Hydrograph Equations	25
Area A		
	Unit Hydrograph Summary, 2 years	27
	Unit Hydrograph Summary, 10 years	29
	Unit Hydrograph Summary, 100 years	31
Area B		
	Unit Hydrograph Summary, 2 years	33
	Unit Hydrograph Summary, 10 years	35
	Unit Hydrograph Summary, 100 years	37
BY-PASS		
	Unit Hydrograph Summary, 2 years	39
	Unit Hydrograph Summary, 10 years	41
	Unit Hydrograph Summary, 100 years	43
O-14		
	Addition Summary, 2 years	45

Table of Contents

	Addition Summary, 10 years	46
	Addition Summary, 100 years	47
Basin A		
	Elevation-Area Volume Curve, 2 years	48
	Volume Equations, 2 years	49
Basin B		
	Elevation-Area Volume Curve, 2 years	50
	Volume Equations, 2 years	51
Composite Outlet Structure - A		
	Outlet Input Data, 2 years	52
Composite Outlet Structure - B		
	Outlet Input Data, 2 years	56
Basin A		
	Elevation-Volume-Flow Table (Pond), 2 years	60
Basin A (IN)		
	Level Pool Pond Routing Summary, 2 years	63
	Level Pool Pond Routing Summary, 10 years	64
	Level Pool Pond Routing Summary, 100 years	65
Basin A (OUT)		
	Pond Routed Hydrograph (total out), 2 years	66
	Pond Routed Hydrograph (total out), 10 years	68
	Pond Routed Hydrograph (total out), 100 years	70
Basin A (IN)		
	Pond Inflow Summary, 2 years	72
	Pond Inflow Summary, 10 years	73
	Pond Inflow Summary, 100 years	74
Basin B		
	Elevation-Volume-Flow Table (Pond), 2 years	75
Basin B (IN)		
	Level Pool Pond Routing Summary, 2 years	77
	Level Pool Pond Routing Summary, 10 years	78
	Level Pool Pond Routing Summary, 100 years	79
Basin B (OUT)		
	Pond Routed Hydrograph (total out), 2 years	80

Table of Contents

	Pond Routed Hydrograph (total out), 10 years	82
	Pond Routed Hydrograph (total out), 100 years	84
Basin B (IN)		
	Pond Inflow Summary, 2 years	87
	Pond Inflow Summary, 10 years	88
	Pond Inflow Summary, 100 years	89

PROPOSED CONDITIONS

Subsection: User Notifications

User Notifications

Message Id	29
Scenario	St. Charles County - Synthetic Curve, 2 yrs
Element Type	Catchment
Element Id	228
Label	BY-PASS
Time	(N/A)
Message	$T_m > .25T_p$. Computation increment, T_m , is greater than 1/4 Time to Peak on Unit Hydrograph. Using a larger T_c can solve this problem.
Source	Warning

Message Id	15
Scenario	St. Charles County - Synthetic Curve, 2 yrs
Element Type	Composite Outlet Structure
Element Id	116
Label	Composite Outlet Structure - A
Time	(N/A)
Message	K_r (reverse flow entrance loss coefficient) was not specified. K_r was set to same value as $K_e = 0.000$.
Source	Warning

Message Id	67
Scenario	St. Charles County - Synthetic Curve, 2 yrs
Element Type	Composite Outlet Structure
Element Id	116
Label	Composite Outlet Structure - A
Time	(N/A)
Message	Flow direction set to reverse for one or more structures in composite outlet structure Composite Outlet Structure - A. To eliminate this warning, edit outlet data and select forward only. If reverse flow analysis is required, then the tailwater conditions must be set to interconnected pond.
Source	Warning

Message Id	19
Scenario	St. Charles County - Synthetic Curve, 2 yrs
Element Type	Composite Outlet Structure
Element Id	116
Label	Composite Outlet Structure - A
Time	(N/A)
Message	Charged riser flow adjusted to weir flow rate to maintain convergence. If adjustments are desired, substitute a user defined outlet rating table for level pool routing. Or, store rating curve(s) in E-Q-TW table, edit, then route with ICPM option.
Source	Warning

PROPOSED CONDITIONS

Subsection: User Notifications

User Notifications

Message Id	15
Scenario	St. Charles County - Synthetic Curve, 2 yrs
Element Type	Composite Outlet Structure
Element Id	248
Label	Composite Outlet Structure - B
Time	(N/A)
Message	Kr (reverse flow entrance loss coefficient) was not specified. Kr was set to same value as Ke=0.000 .
Source	Warning

Message Id	19
Scenario	St. Charles County - Synthetic Curve, 2 yrs
Element Type	Composite Outlet Structure
Element Id	248
Label	Composite Outlet Structure - B
Time	(N/A)
Message	Charged riser flow adjusted to weir flow rate to maintain convergence. If adjustments are desired, substitute a user defined outlet rating table for level pool routing. Or, store rating curve(s) in E-Q-TW table, edit, then route with ICPM option.
Source	Warning

Message Id	29
Scenario	St. Charles County - Synthetic Curve, 10 yrs
Element Type	Catchment
Element Id	228
Label	BY-PASS
Time	(N/A)
Message	$T_m > .25T_p$. Computation increment, T_m , is greater than 1/4 Time to Peak on Unit Hydrograph. Using a larger T_c can solve this problem.
Source	Warning

Message Id	15
Scenario	St. Charles County - Synthetic Curve, 10 yrs
Element Type	Composite Outlet Structure
Element Id	116
Label	Composite Outlet Structure - A
Time	(N/A)
Message	Kr (reverse flow entrance loss coefficient) was not specified. Kr was set to same value as Ke=0.000 .
Source	Warning

PROPOSED CONDITIONS

Subsection: User Notifications

User Notifications

Message Id	67
Scenario	St. Charles County - Synthetic Curve, 10 yrs
Element Type	Composite Outlet Structure
Element Id	116
Label	Composite Outlet Structure - A
Time	(N/A)
Message	Flow direction set to reverse for one ore more structures in composite outlet structure Composite Outlet Structure - A. To eliminate this warning, edit outlet data and select forward only. If reverse flow analysis is required, then the tailwater conditions must be set to interconnected pond.
Source	Warning

Message Id	19
Scenario	St. Charles County - Synthetic Curve, 10 yrs
Element Type	Composite Outlet Structure
Element Id	116
Label	Composite Outlet Structure - A
Time	(N/A)
Message	Charged riser flow adjusted to weir flow rate to maintain convergence. If adjustments are desired, substitute a user defined outlet rating table for level pool routing. Or, store rating curve(s) in E-Q-TW table, edit, then route with ICPM option.
Source	Warning

Message Id	15
Scenario	St. Charles County - Synthetic Curve, 10 yrs
Element Type	Composite Outlet Structure
Element Id	248
Label	Composite Outlet Structure - B
Time	(N/A)
Message	Kr (reverse flow entrance loss coefficient) was not specified. Kr was set to same value as Ke= 0.000 .
Source	Warning

Message Id	19
Scenario	St. Charles County - Synthetic Curve, 10 yrs
Element Type	Composite Outlet Structure
Element Id	248
Label	Composite Outlet Structure - B
Time	(N/A)
Message	Charged riser flow adjusted to weir flow rate to maintaln convergence. If adjustments are desired, substitute a user defined outlet rating table for level pool routing. Or, store rating curve(s) in E-Q-TW table, edit, then route with ICPM option.
Source	Warning

PROPOSED CONDITIONS

Subsection: Master Network Summary

Catchments Summary

Label	Scenario	Return Event (years)	Hydrograph Volume (ft ³)	Time to Peak (hours)	Peak Flow (ft ³ /s)
Area A	St. Charles County - Synthetic Curve, 2 yrs	2	129,061.000	12.050	39.59
Area A	St. Charles County - Synthetic Curve, 10 yrs	10	244,411.000	12.050	82.55
Area A	St. Charles County - Synthetic Curve, 100 yrs	100	487,523.000	12.050	161.04
Area B	St. Charles County - Synthetic Curve, 2 yrs	2	136,031.000	12.050	38.61
Area B	St. Charles County - Synthetic Curve, 10 yrs	10	247,651.000	12.050	77.04
Area B	St. Charles County - Synthetic Curve, 100 yrs	100	478,172.000	12.050	145.91
BY-PASS	St. Charles County - Synthetic Curve, 2 yrs	2	35,652.000	12.100	7.95
BY-PASS	St. Charles County - Synthetic Curve, 10 yrs	10	80,070.000	12.100	22.70
BY-PASS	St. Charles County - Synthetic Curve, 100 yrs	100	184,010.000	12.100	53.16

Node Summary

Label	Scenario	Return Event (years)	Hydrograph Volume (ft ³)	Time to Peak (hours)	Peak Flow (ft ³ /s)
O-14	St. Charles County - Synthetic Curve, 2 yrs	2	300,744.000	12.150	40.36
O-14	St. Charles County - Synthetic Curve, 10 yrs	10	571,921.000	12.150	103.30
O-14	St. Charles County - Synthetic Curve, 100 yrs	100	1,149,705.000	12.150	267.04

Pond Summary

PROPOSED CONDITIONS

Subsection: Master Network Summary

Pond Summary

Label	Scenario	Return Event (years)	Hydrograph Volume (ft ³)	Time to Peak (hours)	Peak Flow (ft ³ /s)	Maximum Water Surface Elevation (ft)	Maximum Pond Storage (ft ³)
Basin B (IN)	St. Charles County - Synthetic Curve, 2 yrs	2	136,031.000	12.050	38.61	(N/A)	(N/A)
Basin B (OUT)	St. Charles County - Synthetic Curve, 2 yrs	2	136,031.000	12.250	22.40	544.36	16,853.000
Basin B (IN)	St. Charles County - Synthetic Curve, 10 yrs	10	247,651.000	12.050	77.04	(N/A)	(N/A)
Basin B (OUT)	St. Charles County - Synthetic Curve, 10 yrs	10	247,651.000	12.150	68.99	545.22	30,594.000
Basin B (IN)	St. Charles County - Synthetic Curve, 100 yrs	100	478,172.000	12.050	145.91	(N/A)	(N/A)
Basin B (OUT)	St. Charles County - Synthetic Curve, 100 yrs	100	478,172.000	12.150	124.75	546.07	47,200.000
Basin A (IN)	St. Charles County - Synthetic Curve, 2 yrs	2	129,061.000	12.050	39.59	(N/A)	(N/A)
Basin A (OUT)	St. Charles County - Synthetic Curve, 2 yrs	2	129,061.000	12.350	11.64	564.60	30,407.000
Basin A (IN)	St. Charles County - Synthetic Curve, 10 yrs	10	244,411.000	12.050	82.55	(N/A)	(N/A)
Basin A (OUT)	St. Charles County - Synthetic Curve, 10 yrs	10	244,301.000	12.450	15.04	566.34	85,827.000
Basin A (IN)	St. Charles County - Synthetic Curve, 100 yrs	100	487,523.000	12.050	161.04	(N/A)	(N/A)

PROPOSED CONDITIONS

Subsection: Master Network Summary

Pond Summary

Label	Scenario	Return Event (years)	Hydrograph Volume (ft ³)	Time to Peak (hours)	Peak Flow (ft ³ /s)	Maximum Water Surface Elevation (ft)	Maximum Pond Storage (ft ³)
Basin A (OUT)	St. Charles County - Synthetic Curve, 100 yrs	100	487,523.000	12.200	96.62	567.73	136,541.000

PROPOSED CONDITIONS

Subsection: Time-Depth Curve
 Label: St. Charles County

Return Event: 2 years
 Storm Event: TypeII 24hr (3.25 in)

Time-Depth Curve: TypeII 24hr (3.25 in)

Label	TypeII 24hr (3.25 in)
Start Time	0.000 hours
Increment	0.100 hours
End Time	24.000 hours
Return Event	2 years

CUMULATIVE RAINFALL (in)

Output Time Increment = 0.100 hours

Time on left represents time for first value in each row.

Time (hours)	Depth (in)	Depth (in)	Depth (in)	Depth (in)	Depth (in)
0.000	0.0	0.0	0.0	0.0	0.0
0.500	0.0	0.0	0.0	0.0	0.0
1.000	0.0	0.0	0.0	0.0	0.0
1.500	0.1	0.1	0.1	0.1	0.1
2.000	0.1	0.1	0.1	0.1	0.1
2.500	0.1	0.1	0.1	0.1	0.1
3.000	0.1	0.1	0.1	0.1	0.1
3.500	0.1	0.1	0.1	0.1	0.2
4.000	0.2	0.2	0.2	0.2	0.2
4.500	0.2	0.2	0.2	0.2	0.2
5.000	0.2	0.2	0.2	0.2	0.2
5.500	0.2	0.2	0.2	0.2	0.3
6.000	0.3	0.3	0.3	0.3	0.3
6.500	0.3	0.3	0.3	0.3	0.3
7.000	0.3	0.3	0.3	0.3	0.3
7.500	0.4	0.4	0.4	0.4	0.4
8.000	0.4	0.4	0.4	0.4	0.4
8.500	0.4	0.4	0.4	0.5	0.5
9.000	0.5	0.5	0.5	0.5	0.5
9.500	0.5	0.5	0.6	0.6	0.6
10.000	0.6	0.6	0.6	0.6	0.6
10.500	0.7	0.7	0.7	0.7	0.7
11.000	0.8	0.8	0.8	0.8	0.9
11.500	0.9	1.0	1.2	1.4	1.8
12.000	2.2	2.2	2.3	2.3	2.4
12.500	2.4	2.4	2.4	2.5	2.5
13.000	2.5	2.5	2.5	2.6	2.6
13.500	2.6	2.6	2.6	2.6	2.7
14.000	2.7	2.7	2.7	2.7	2.7
14.500	2.7	2.7	2.7	2.8	2.8
15.000	2.8	2.8	2.8	2.8	2.8
15.500	2.8	2.8	2.8	2.8	2.9
16.000	2.9	2.9	2.9	2.9	2.9

PROPOSED CONDITIONS

Subsection: Time-Depth Curve
 Label: St. Charles County

Return Event: 2 years
 Storm Event: TypeII 24hr (3.25 in)

CUMULATIVE RAINFALL (in) Output Time Increment = 0.100 hours

Time on left represents time for first value in each row.

Time (hours)	Depth (in)	Depth (in)	Depth (in)	Depth (in)	Depth (in)
16.500	2.9	2.9	2.9	2.9	2.9
17.000	2.9	2.9	2.9	3.0	3.0
17.500	3.0	3.0	3.0	3.0	3.0
18.000	3.0	3.0	3.0	3.0	3.0
18.500	3.0	3.0	3.0	3.0	3.0
19.000	3.0	3.1	3.1	3.1	3.1
19.500	3.1	3.1	3.1	3.1	3.1
20.000	3.1	3.1	3.1	3.1	3.1
20.500	3.1	3.1	3.1	3.1	3.1
21.000	3.1	3.1	3.1	3.1	3.2
21.500	3.2	3.2	3.2	3.2	3.2
22.000	3.2	3.2	3.2	3.2	3.2
22.500	3.2	3.2	3.2	3.2	3.2
23.000	3.2	3.2	3.2	3.2	3.2
23.500	3.2	3.2	3.2	3.2	3.2
24.000	3.4	(N/A)	(N/A)	(N/A)	(N/A)

PROPOSED CONDITIONS

Subsection: Time-Depth Curve
 Label: St. Charles County

Return Event: 10 years
 Storm Event: TypeII 24hr (5.0 in)

Time-Depth Curve: TypeII 24hr (5.0 in)	
Label	TypeII 24hr (5.0 in)
Start Time	0.000 hours
Increment	0.100 hours
End Time	24.000 hours
Return Event	10 years

CUMULATIVE RAINFALL (in)

Output Time Increment = 0.100 hours

Time on left represents time for first value in each row.

Time (hours)	Depth (in)	Depth (in)	Depth (in)	Depth (in)	Depth (in)
0.000	0.0	0.0	0.0	0.0	0.0
0.500	0.0	0.0	0.0	0.0	0.0
1.000	0.1	0.1	0.1	0.1	0.1
1.500	0.1	0.1	0.1	0.1	0.1
2.000	0.1	0.1	0.1	0.1	0.1
2.500	0.1	0.1	0.2	0.2	0.2
3.000	0.2	0.2	0.2	0.2	0.2
3.500	0.2	0.2	0.2	0.2	0.2
4.000	0.2	0.2	0.3	0.3	0.3
4.500	0.3	0.3	0.3	0.3	0.3
5.000	0.3	0.3	0.3	0.3	0.3
5.500	0.4	0.4	0.4	0.4	0.4
6.000	0.4	0.4	0.4	0.4	0.4
6.500	0.4	0.5	0.5	0.5	0.5
7.000	0.5	0.5	0.5	0.5	0.5
7.500	0.5	0.6	0.6	0.6	0.6
8.000	0.6	0.6	0.6	0.6	0.6
8.500	0.7	0.7	0.7	0.7	0.7
9.000	0.7	0.8	0.8	0.8	0.8
9.500	0.8	0.8	0.8	0.9	0.9
10.000	0.9	0.9	0.9	1.0	1.0
10.500	1.0	1.0	1.1	1.1	1.1
11.000	1.2	1.2	1.3	1.3	1.4
11.500	1.4	1.5	1.8	2.2	2.8
12.000	3.3	3.4	3.5	3.6	3.6
12.500	3.7	3.7	3.8	3.8	3.8
13.000	3.9	3.9	3.9	3.9	4.0
13.500	4.0	4.0	4.0	4.1	4.1
14.000	4.1	4.1	4.1	4.2	4.2
14.500	4.2	4.2	4.2	4.2	4.3
15.000	4.3	4.3	4.3	4.3	4.3
15.500	4.3	4.4	4.4	4.4	4.4
16.000	4.4	4.4	4.4	4.4	4.4

PROPOSED CONDITIONS

Subsection: Time-Depth Curve
 Label: St. Charles County

Return Event: 10 years
 Storm Event: TypeII 24hr (5.0 in)

CUMULATIVE RAINFALL (in) Output Time Increment = 0.100 hours

Time on left represents time for first value in each row.

Time (hours)	Depth (in)	Depth (in)	Depth (in)	Depth (in)	Depth (in)
16.500	4.5	4.5	4.5	4.5	4.5
17.000	4.5	4.5	4.5	4.5	4.5
17.500	4.6	4.6	4.6	4.6	4.6
18.000	4.6	4.6	4.6	4.6	4.6
18.500	4.6	4.7	4.7	4.7	4.7
19.000	4.7	4.7	4.7	4.7	4.7
19.500	4.7	4.7	4.7	4.7	4.8
20.000	4.8	4.8	4.8	4.8	4.8
20.500	4.8	4.8	4.8	4.8	4.8
21.000	4.8	4.8	4.8	4.8	4.8
21.500	4.9	4.9	4.9	4.9	4.9
22.000	4.9	4.9	4.9	4.9	4.9
22.500	4.9	4.9	4.9	4.9	4.9
23.000	4.9	4.9	5.0	5.0	5.0
23.500	5.0	5.0	5.0	5.0	5.0
24.000	5.0	(N/A)	(N/A)	(N/A)	(N/A)

PROPOSED CONDITIONS

Subsection: Time-Depth Curve
 Label: St. Charles County

Return Event: 100 years
 Storm Event: TypeII 24hr (8.0 in)

Time-Depth Curve: TypeII 24hr (8.0 in)	
Label	TypeII 24hr (8.0 in)
Start Time	0.000 hours
Increment	0.100 hours
End Time	24.000 hours
Return Event	100 years

CUMULATIVE RAINFALL (in)

Output Time Increment = 0.100 hours

Time on left represents time for first value in each row.

Time (hours)	Depth (in)	Depth (in)	Depth (in)	Depth (in)	Depth (in)
0.000	0.0	0.0	0.0	0.0	0.0
0.500	0.0	0.0	0.1	0.1	0.1
1.000	0.1	0.1	0.1	0.1	0.1
1.500	0.1	0.1	0.1	0.2	0.2
2.000	0.2	0.2	0.2	0.2	0.2
2.500	0.2	0.2	0.2	0.3	0.3
3.000	0.3	0.3	0.3	0.3	0.3
3.500	0.3	0.3	0.4	0.4	0.4
4.000	0.4	0.4	0.4	0.4	0.4
4.500	0.4	0.5	0.5	0.5	0.5
5.000	0.5	0.5	0.5	0.5	0.6
5.500	0.6	0.6	0.6	0.6	0.6
6.000	0.6	0.7	0.7	0.7	0.7
6.500	0.7	0.7	0.7	0.8	0.8
7.000	0.8	0.8	0.8	0.8	0.9
7.500	0.9	0.9	0.9	0.9	0.9
8.000	1.0	1.0	1.0	1.0	1.0
8.500	1.1	1.1	1.1	1.1	1.2
9.000	1.2	1.2	1.2	1.3	1.3
9.500	1.3	1.3	1.4	1.4	1.4
10.000	1.4	1.5	1.5	1.6	1.6
10.500	1.6	1.7	1.7	1.8	1.8
11.000	1.9	1.9	2.0	2.1	2.2
11.500	2.3	2.5	2.8	3.4	4.5
12.000	5.3	5.5	5.6	5.7	5.8
12.500	5.9	5.9	6.0	6.1	6.1
13.000	6.2	6.2	6.3	6.3	6.4
13.500	6.4	6.4	6.5	6.5	6.5
14.000	6.6	6.6	6.6	6.6	6.7
14.500	6.7	6.7	6.8	6.8	6.8
15.000	6.8	6.9	6.9	6.9	6.9
15.500	6.9	7.0	7.0	7.0	7.0
16.000	7.0	7.1	7.1	7.1	7.1

PROPOSED CONDITIONS

Subsection: Time-Depth Curve
 Label: St. Charles County

Return Event: 100 years
 Storm Event: TypeII 24hr (8.0 in)

CUMULATIVE RAINFALL (in) Output Time Increment = 0.100 hours

Time on left represents time for first value in each row.

Time (hours)	Depth (in)	Depth (in)	Depth (in)	Depth (in)	Depth (in)
16.500	7.1	7.1	7.2	7.2	7.2
17.000	7.2	7.2	7.2	7.3	7.3
17.500	7.3	7.3	7.3	7.3	7.4
18.000	7.4	7.4	7.4	7.4	7.4
18.500	7.4	7.5	7.5	7.5	7.5
19.000	7.5	7.5	7.5	7.5	7.6
19.500	7.6	7.6	7.6	7.6	7.6
20.000	7.6	7.6	7.6	7.6	7.7
20.500	7.7	7.7	7.7	7.7	7.7
21.000	7.7	7.7	7.7	7.7	7.8
21.500	7.8	7.8	7.8	7.8	7.8
22.000	7.8	7.8	7.8	7.8	7.9
22.500	7.9	7.9	7.9	7.9	7.9
23.000	7.9	7.9	7.9	7.9	7.9
23.500	8.0	8.0	8.0	8.0	8.0
24.000	8.0	(N/A)	(N/A)	(N/A)	(N/A)

PROPOSED CONDITIONS

Subsection: Time of Concentration Calculations
Label: Area A

Return Event: 2 years
Storm Event: TypeII 24hr (3.25 in)

Time of Concentration Results

Segment #1: TR-55 Sheet Flow	
Hydraulic Length	100.00 ft
Manning's n	0.240
Slope	0.030 ft/ft
2 Year 24 Hour Depth	3.3 in
Average Velocity	0.14 ft/s
Segment Time of Concentration	0.201 hours

Segment #2: TR-55 Shallow Concentrated Flow	
Hydraulic Length	65.00 ft
Is Paved?	False
Slope	0.266 ft/ft
Average Velocity	8.32 ft/s
Segment Time of Concentration	0.002 hours

Segment #3: TR-55 Shallow Concentrated Flow	
Hydraulic Length	270.00 ft
Is Paved?	False
Slope	0.052 ft/ft
Average Velocity	3.68 ft/s
Segment Time of Concentration	0.020 hours

Segment #4: TR-55 Channel Flow	
Flow Area	2.4 ft ²
Hydraulic Length	83.00 ft
Manning's n	0.013
Slope	0.006 ft/ft
Wetted Perimeter	5.50 ft
Average Velocity	5.12 ft/s
Segment Time of Concentration	0.005 hours

Segment #5: TR-55 Channel Flow	
Flow Area	2.4 ft ²
Hydraulic Length	67.00 ft
Manning's n	0.013
Slope	0.020 ft/ft
Wetted Perimeter	5.50 ft

PROPOSED CONDITIONS

Subsection: Time of Concentration Calculations
 Label: Area A

Return Event: 2 years
 Storm Event: TypeII 24hr (3.25 in)

Segment #5: TR-55 Channel Flow	
Average Velocity	9.35 ft/s
Segment Time of Concentration	0.002 hours
Segment #6: TR-55 Channel Flow	
Flow Area	3.1 ft ²
Hydraulic Length	35.00 ft
Manning's n	0.013
Slope	0.020 ft/ft
Wetted Perimeter	6.28 ft
Average Velocity	10.21 ft/s
Segment Time of Concentration	0.001 hours
Segment #7: TR-55 Channel Flow	
Flow Area	3.1 ft ²
Hydraulic Length	220.00 ft
Manning's n	0.013
Slope	0.006 ft/ft
Wetted Perimeter	6.28 ft
Average Velocity	5.59 ft/s
Segment Time of Concentration	0.011 hours
Time of Concentration (Composite)	
Time of Concentration (Composite)	0.242 hours

PROPOSED CONDITIONS

Subsection: Time of Concentration Calculations

Label: Area A

Return Event: 2 years

Storm Event: TypeII 24hr (3.25 in)

==== SCS Channel Flow

$$T_c = \frac{R = Q_a / W_p}{V = (1.49 * (R^{2/3}) * (S_f^{0.5})) / n}$$

Where:

$(L_f / V) / 3600$
R= Hydraulic radius
Aq= Flow area, square feet
Wp= Wetted perimeter, feet
V= Velocity, ft/sec
Sf= Slope, ft/ft
n= Manning's n
Tc= Time of concentration, hours
Lf= Flow length, feet

==== SCS TR-55 Shallow Concentration Flow

Unpaved surface:
 $V = 16.1345 * (S_f^{0.5})$

Paved Surface:
 $V = 20.3282 * (S_f^{0.5})$

Where:

$(L_f / V) / 3600$
V= Velocity, ft/sec
Sf= Slope, ft/ft
Tc= Time of concentration, hours
Lf= Flow length, feet

==== SCS TR-55 Sheet Flow

$$T_c = \frac{0.007 * ((n * L_f)^{0.8})}{((P^{0.5}) * (S_f^{0.4}))}$$

Where:

Tc= Time of concentration, hours
n= Manning's n
Lf= Flow length, feet
P= 2yr, 24hr Rain depth, inches
Sf= Slope, %

PROPOSED CONDITIONS

Subsection: Time of Concentration Calculations

Return Event: 2 years

Label: Area B

Storm Event: TypeII 24hr (3.25 in)

Time of Concentration Results

Segment #1: TR-55 Sheet Flow	
Hydraulic Length	100.00 ft
Manning's n	0.240
Slope	0.020 ft/ft
2 Year 24 Hour Depth	3.3 in
Average Velocity	0.12 ft/s
Segment Time of Concentration	0.236 hours
Segment #2: TR-55 Shallow Concentrated Flow	
Hydraulic Length	180.00 ft
Is Paved?	False
Slope	0.030 ft/ft
Average Velocity	2.79 ft/s
Segment Time of Concentration	0.018 hours
Segment #3: TR-55 Channel Flow	
Flow Area	0.8 ft ²
Hydraulic Length	145.00 ft
Manning's n	0.013
Slope	0.010 ft/ft
Wetted Perimeter	3.14 ft
Average Velocity	4.57 ft/s
Segment Time of Concentration	0.009 hours
Segment #4: TR-55 Channel Flow	
Flow Area	1.8 ft ²
Hydraulic Length	465.00 ft
Manning's n	0.013
Slope	0.020 ft/ft
Wetted Perimeter	4.71 ft
Average Velocity	8.41 ft/s
Segment Time of Concentration	0.015 hours
Segment #5: TR-55 Channel Flow	
Flow Area	3.1 ft ²
Hydraulic Length	370.00 ft
Manning's n	0.013

PROPOSED CONDITIONS

Subsection: Time of Concentration Calculations
Label: Area B

Return Event: 2 years
Storm Event: TypeII 24hr (3.25 in)

Segment #5: TR-55 Channel Flow	
Slope	0.050 ft/ft
Wetted Perimeter	6.28 ft
Average Velocity	16.15 ft/s
Segment Time of Concentration	0.006 hours

Segment #6: TR-55 Channel Flow	
Flow Area	4.9 ft ²
Hydraulic Length	220.00 ft
Manning's n	0.013
Slope	0.010 ft/ft
Wetted Perimeter	7.85 ft
Average Velocity	8.38 ft/s
Segment Time of Concentration	0.007 hours

Time of Concentration (Composite)	
Time of Concentration (Composite)	0.292 hours

PROPOSED CONDITIONS

Subsection: Time of Concentration Calculations

Label: Area B

Return Event: 2 years

Storm Event: TypeII 24hr (3.25 in)

==== SCS Channel Flow

$$T_c = \frac{R = Q_a / W_p}{V = (1.49 * (R^{2/3}) * (S_f^{-0.5})) / n}$$

$$(L_f / V) / 3600$$

R= Hydraulic radius

A_q= Flow area, square feet

W_p= Wetted perimeter, feet

V= Velocity, ft/sec

Where:

S_f= Slope, ft/ft

n= Manning's n

T_c= Time of concentration, hours

L_f= Flow length, feet

==== SCS TR-55 Shallow Concentration Flow

Unpaved surface:

$$V = 16.1345 * (S_f^{0.5})$$

T_c =

Paved Surface:

$$V = 20.3282 * (S_f^{0.5})$$

$$(L_f / V) / 3600$$

V= Velocity, ft/sec

Where:

S_f= Slope, ft/ft

T_c= Time of concentration, hours

L_f= Flow length, feet

==== SCS TR-55 Sheet Flow

$$T_c = \frac{(0.007 * ((n * L_f)^{0.8}))}{((P^{0.5}) * (S_f^{0.4}))}$$

T_c= Time of concentration, hours

n= Manning's n

Where:

L_f= Flow length, feet

P= 2yr, 24hr Rain depth, inches

S_f= Slope, %

PROPOSED CONDITIONS

Subsection: Time of Concentration Calculations
 Label: BY-PASS

Return Event: 2 years
 Storm Event: TypeII 24hr (3.25 in)

Time of Concentration Results

Segment #1: TR-55 Sheet Flow	
Hydraulic Length	120.00 ft
Manning's n	0.240
Slope	0.020 ft/ft
2 Year 24 Hour Depth	3.3 in
Average Velocity	0.12 ft/s
Segment Time of Concentration	0.273 hours
Segment #2: TR-55 Shallow Concentrated Flow	
Hydraulic Length	203.00 ft
Is Paved?	True
Slope	0.020 ft/ft
Average Velocity	2.87 ft/s
Segment Time of Concentration	0.020 hours
Segment #3: TR-55 Channel Flow	
Flow Area	1.8 ft ²
Hydraulic Length	120.00 ft
Manning's n	0.013
Slope	0.010 ft/ft
Wetted Perimeter	4.70 ft
Average Velocity	5.95 ft/s
Segment Time of Concentration	0.006 hours
Segment #4: TR-55 Channel Flow	
Flow Area	12.6 ft ²
Hydraulic Length	180.00 ft
Manning's n	0.013
Slope	0.005 ft/ft
Wetted Perimeter	12.57 ft
Average Velocity	8.10 ft/s
Segment Time of Concentration	0.006 hours
Time of Concentration (Composite)	
Time of Concentration (Composite)	0.304 hours

PROPOSED CONDITIONS

Subsection: Time of Concentration Calculations

Label: BY-PASS

Return Event: 2 years

Storm Event: TypeII 24hr (3.25 in)

==== SCS Channel Flow

$$T_c = \frac{R = Q_a / W_p}{V = (1.49 * (R^{2/3}) * (S_f^{0.5})) / n}$$

$$(L_f / V) / 3600$$

R= Hydraulic radius

A_q= Flow area, square feet

W_p= Wetted perimeter, feet

V= Velocity, ft/sec

Where:

S_f= Slope, ft/ft

n= Manning's n

T_c= Time of concentration, hours

L_f= Flow length, feet

==== SCS TR-55 Shallow Concentration Flow

Unpaved surface:

$$V = 16.1345 * (S_f^{0.5})$$

T_c =

Paved Surface:

$$V = 20.3282 * (S_f^{0.5})$$

$$(L_f / V) / 3600$$

V= Velocity, ft/sec

Where:

S_f= Slope, ft/ft

T_c= Time of concentration, hours

L_f= Flow length, feet

==== SCS TR-55 Sheet Flow

$$T_c = \frac{(0.007 * ((n * L_f)^{0.8}))}{((P^{0.5}) * (S_f^{0.4}))}$$

T_c= Time of concentration, hours

n= Manning's n

Where:

L_f= Flow length, feet

P= 2yr, 24hr Rain depth, inches

S_f= Slope, %

PROPOSED CONDITIONS

Subsection: Runoff CN-Area
 Label: Area A

Return Event: 2 years
 Storm Event: TypeII 24hr (3.25 in)

Runoff Curve Number Data

Soil/Surface Description	CN	Area (ft ²)	C (%)	UC (%)	Adjusted CN
Residential Districts - 1/4 acre - Soil D	87.000	54,450.000	0.0	0.0	87.000
Residential Districts - 1/4 acre - Soil C	83.000	473,061.600	0.0	0.0	83.000
Open space (Lawns,parks etc.) - Good condition; grass cover > 75% - Soil C	74.000	209,959.200	0.0	0.0	74.000
Open space (Lawns,parks etc.) - Good condition; grass cover > 75% - Soil D	80.000	12,196.800	0.0	0.0	80.000
Woods - grass combination - good - Soil C	72.000	335,412.000	0.0	0.0	72.000
COMPOSITE AREA & WEIGHTED CN --->	(N/A)	1,085,079.600	(N/A)	(N/A)	78.025

PROPOSED CONDITIONS

Subsection: Runoff CN-Area
 Label: Area B

Return Event: 2 years
 Storm Event: TypeII 24hr (3.25 in)

Runoff Curve Number Data

Soil/Surface Description	CN	Area (ft ²)	C (%)	UC (%)	Adjusted CN
Residential Districts - 1/4 acre - Soil B	75.000	238,273.200	0.0	0.0	75.000
Residential Districts - 1/4 acre - Soil C	83.000	579,783.600	0.0	0.0	83.000
Residential Districts - 1/4 acre - Soil D	87.000	141,134.400	0.0	0.0	87.000
Open space (Lawns,parks etc.) - Good condition; grass cover > 75% - Soil B	61.000	33,105.600	0.0	0.0	61.000
Open space (Lawns,parks etc.) - Good condition; grass cover > 75% - Soil C	74.000	6,969.600	0.0	0.0	74.000
COMPOSITE AREA & WEIGHTED CN --->	(N/A)	999,266.400	(N/A)	(N/A)	80.866

PROPOSED CONDITIONS

Subsection: Runoff CN-Area
 Label: BY-PASS

Return Event: 2 years
 Storm Event: TypeII 24hr (3.25 in)

Runoff Curve Number Data

Soil/Surface Description	CN	Area (ft ²)	C (%)	UC (%)	Adjusted CN
Meadow - cont. grass (non grazed) - ---- - Soil B	58.000	145,926.000	0.0	0.0	58.000
Meadow - cont. grass (non grazed) - ---- - Soil C	71.000	57,499.200	0.0	0.0	71.000
Woods - good - Soil B	55.000	94,089.600	0.0	0.0	55.000
Residential Districts - 1/4 acre - Soil B	75.000	183,823.200	0.0	0.0	75.000
Residential Districts - 1/4 acre - Soil C	83.000	54,450.000	0.0	0.0	83.000
COMPOSITE AREA & WEIGHTED CN --->	(N/A)	535,788.000	(N/A)	(N/A)	67.241

PROPOSED CONDITIONS

Subsection: Unit Hydrograph Equations

Unit Hydrograph Method (Computational Notes)

Definition of Terms

At	Total area (acres): $A_t = A_i + A_p$
Ai	Impervious area (acres)
Ap	Pervious area (acres)
CNI	Runoff curve number for impervious area
CNp	Runoff curve number for pervious area
fLoss	f loss constant infiltration (depth/time)
gKs	Saturated Hydraulic Conductivity (depth/time)
Md	Volumetric Moisture Deficit
Psi	Capillary Suction (length)
hK	Horton Infiltration Decay Rate (time^{-1})
fo	Initial Infiltration Rate (depth/time)
fc	Ultimate(capacity)Infiltration Rate (depth/time)
Ia	Initial Abstraction (length)
dt	Computational increment (duration of unit excess rainfall) Default dt is smallest value of $0.1333T_c$, t_{rm} , and t_h (Smallest dt is then adjusted to match up with T_p)
UDdt	User specified override computational main time increment (only used if UDdt is $\Rightarrow .1333T_c$)
D(t)	Point on distribution curve (fraction of P) for time step t
K	$2 / (1 + (T_r/T_p))$: default K = 0.75: (for $T_r/T_p = 1.67$)
Ks	Hydrograph shape factor = Unit Conversions * K: = $((1\text{hr}/3600\text{sec}) * (1\text{ft}/12\text{in}) * ((5280\text{ft})^2/\text{sq.mi})) * K$ Default Ks = $645.333 * 0.75 = 484$
Lag	Lag time from center of excess runoff (dt) to T_p : Lag = $0.6T_c$
P	Total precipitation depth, inches
Pa(t)	Accumulated rainfall at time step t
Pi(t)	Incremental rainfall at time step t
qp	Peak discharge (cfs) for 1in. runoff, for 1hr, for 1 sq.mi. = $(K_s * A * Q) / T_p$ (where Q = 1in. runoff, A=sq.mi.)
Qu(t)	Unit hydrograph ordinate (cfs) at time step t
Q(t)	Final hydrograph ordinate (cfs) at time step t
Rai(t)	Accumulated runoff (inches) at time step t for impervious area
Rap(t)	Accumulated runoff (inches) at time step t for pervious area
Rii(t)	Incremental runoff (inches) at time step t for impervious area
Rip(t)	Incremental runoff (inches) at time step t for pervious area
R(t)	Incremental weighted total runoff (inches)
Rtm	Time increment for rainfall table
Si	S for impervious area: $S_i = (1000/CNI) - 10$
Sp	S for pervious area: $S_p = (1000/CNp) - 10$
t	Time step (row) number
Tc	Time of concentration
Tb	Time (hrs) of entire unit hydrograph: $T_b = T_p + T_r$
Tp	Time (hrs) to peak of a unit hydrograph: $T_p = (dt/2) + \text{Lag}$
Tr	Time (hrs) of receding limb of unit hydrograph: $T_r = \text{ratio of } T_p$

PROPOSED CONDITIONS

Subsection: Unit Hydrograph Equations

Unit Hydrograph Method

Computational Notes

Precipitation

Column (1)	Time for time step t
Column (2)	$D(t)$ = Point on distribution curve for time step t
Column (3)	$P_i(t) = P_a(t) - P_a(t-1)$: Col.(4) - Preceding Col.(4)
Column (4)	$P_a(t) = D(t) \times P$: Col.(2) \times P

Pervious Area Runoff (using SCS Runoff CN Method)

Column (5)	$Rap(t)$ = Accumulated pervious runoff for time step t If $(P_a(t) \text{ is } \leq 0.2Sp)$ then use: $Rap(t) = 0.0$ If $(P_a(t) \text{ is } > 0.2Sp)$ then use: $Rap(t) = (Col.(4) - 0.2Sp) \times 2 / (Col.(4) + 0.8Sp)$
Column (6)	$Rip(t)$ = Incremental pervious runoff for time step t $Rip(t) = Rap(t) - Rap(t-1)$ $Rip(t) = Col.(5) \text{ for current row} - Col.(5) \text{ for preceding row.}$

Impervious Area Runoff

Column (7 & 8)... Did not specify to use impervious areas.

Incremental Weighted Runoff

Column (9)	$R(t) = (A_p/A_t) \times Rip(t) + (A_i/A_t) \times R_{ii}(t)$ $R(t) = (A_p/A_t) \times Col.(6) + (A_i/A_t) \times Col.(8)$
------------	---

SCS Unit Hydrograph Method

Column (10) $Q(t)$ is computed with the SCS unit hydrograph method using $R(t)$ and $Qu(t)$.

PROPOSED CONDITIONS

Subsection: Unit Hydrograph Summary
 Label: Area A

Return Event: 2 years
 Storm Event: TypeII 24hr (3.25 in)

Storm Event	TypeII 24hr (3.25 in)
Return Event	2 years
Duration	35.000 hours
Depth	3.4 in
Time of Concentration (Composite)	0.242 hours
Area (User Defined)	1,085,079.600 ft ²
<hr/>	
Computational Time Increment	0.032 hours
Time to Peak (Computed)	12.047 hours
Flow (Peak, Computed)	39.70 ft ³ /s
Output Increment	0.050 hours
Time to Flow (Peak Interpolated Output)	12.050 hours
Flow (Peak Interpolated Output)	39.59 ft ³ /s
<hr/>	
Drainage Area	
SCS CN (Composite)	78.000
Area (User Defined)	1,085,079.600 ft ²
Maximum Retention (Pervious)	2.8 in
Maximum Retention (Pervious, 20 percent)	0.6 in
<hr/>	
Cumulative Runoff	
Cumulative Runoff Depth (Pervious)	1.4 in
Runoff Volume (Pervious)	129,057.654 ft ³
<hr/>	
Hydrograph Volume (Area under Hydrograph curve)	
Volume	129,061.000 ft ³
<hr/>	
SCS Unit Hydrograph Parameters	
Time of Concentration (Composite)	0.242 hours
Computational Time Increment	0.032 hours
Unit Hydrograph Shape Factor	483.432
K Factor	0.749
Receding/Rising, Tr/Tp	1.670

PROPOSED CONDITIONS

Subsection: Unit Hydrograph Summary
Label: Area A

Return Event: 2 years
Storm Event: TypeII 24hr (3.25 in)

SCS Unit Hydrograph Parameters	
Unit peak, qp	116.83 ft ³ /s
Unit peak time, Tp	0.161 hours
Unit receding limb, Tr	0.644 hours
Total unit time, Tb	0.805 hours

PROPOSED CONDITIONS

Subsection: Unit Hydrograph Summary

Return Event: 10 years

Label: Area A

Storm Event: TypeII 24hr (5.0 in)

Storm Event	TypeII 24hr (5.0 in)
Return Event	10 years
Duration	24.000 hours
Depth	5.0 in
Time of Concentration (Composite)	0.242 hours
Area (User Defined)	1,085,079.600 ft ²
<hr/>	
Computational Time Increment	0.032 hours
Time to Peak (Computed)	12.047 hours
Flow (Peak, Computed)	82.85 ft ³ /s
Output Increment	0.050 hours
Time to Flow (Peak Interpolated Output)	12.050 hours
Flow (Peak Interpolated Output)	82.55 ft ³ /s
<hr/>	
Drainage Area	
SCS CN (Composite)	78.000
Area (User Defined)	1,085,079.600 ft ²
Maximum Retention (Pervious)	2.8 in
Maximum Retention (Pervious, 20 percent)	0.6 in
<hr/>	
Cumulative Runoff	
Cumulative Runoff Depth (Pervious)	2.7 in
Runoff Volume (Pervious)	245,200.593 ft ³
<hr/>	
Hydrograph Volume (Area under Hydrograph curve)	
Volume	244,411.000 ft ³
<hr/>	
SCS Unit Hydrograph Parameters	
Time of Concentration (Composite)	0.242 hours
Computational Time Increment	0.032 hours
Unit Hydrograph Shape Factor	483.432
K Factor	0.749
Receding/Rising, Tr/Tp	1.670

PROPOSED CONDITIONS

Subsection: Unit Hydrograph Summary
Label: Area A

Return Event: 10 years
Storm Event: TypeII 24hr (5.0 in)

SCS Unit Hydrograph Parameters	
Unit peak, qp	116.83 ft ³ /s
Unit peak time, Tp	0.161 hours
Unit receding limb, Tr	0.644 hours
Total unit time, Tb	0.805 hours

PROPOSED CONDITIONS

Subsection: Unit Hydrograph Summary

Return Event: 100 years

Label: Area A

Storm Event: TypeII 24hr (8.0 in)

Storm Event	TypeII 24hr (8.0 in)
Return Event	100 years
Duration	35.000 hours
Depth	8.0 in
Time of Concentration (Composite)	0.242 hours
Area (User Defined)	1,085,079.600 ft ²
<hr/>	
Computational Time Increment	0.032 hours
Time to Peak (Computed)	12.047 hours
Flow (Peak, Computed)	161.73 ft ³ /s
Output Increment	0.050 hours
Time to Flow (Peak Interpolated Output)	12.050 hours
Flow (Peak Interpolated Output)	161.04 ft ³ /s
<hr/>	
Drainage Area	
SCS CN (Composite)	78.000
Area (User Defined)	1,085,079.600 ft ²
Maximum Retention (Pervious)	2.8 in
Maximum Retention (Pervious, 20 percent)	0.6 in
<hr/>	
Cumulative Runoff	
Cumulative Runoff Depth (Pervious)	5.4 in
Runoff Volume (Pervious)	487,474.329 ft ³
<hr/>	
Hydrograph Volume (Area under Hydrograph curve)	
Volume	487,523.000 ft ³
<hr/>	
SCS Unit Hydrograph Parameters	
Time of Concentration (Composite)	0.242 hours
Computational Time Increment	0.032 hours
Unit Hydrograph Shape Factor	483.432
K Factor	0.749
Receding/Rising, Tr/Tp	1.670

PROPOSED CONDITIONS

Subsection: Unit Hydrograph Summary
Label: Area A

Return Event: 100 years
Storm Event: TypeII 24hr (8.0 in)

SCS Unit Hydrograph Parameters	
Unit peak, qp	116.83 ft ³ /s
Unit peak time, Tp	0.161 hours
Unit receding limb, Tr	0.644 hours
Total unit time, Tb	0.805 hours

PROPOSED CONDITIONS

Subsection: Unit Hydrograph Summary
 Label: Area B

Return Event: 2 years
 Storm Event: TypeII 24hr (3.25 in)

Storm Event	TypeII 24hr (3.25 in)
Return Event	2 years
Duration	35.000 hours
Depth	3.4 in
Time of Concentration (Composite)	0.292 hours
Area (User Defined)	999,266.400 ft ²
<hr/>	
Computational Time Increment	0.039 hours
Time to Peak (Computed)	12.058 hours
Flow (Peak, Computed)	39.07 ft ³ /s
Output Increment	0.050 hours
Time to Flow (Peak Interpolated Output)	12.050 hours
Flow (Peak Interpolated Output)	38.61 ft ³ /s
<hr/>	
Drainage Area	
SCS CN (Composite)	81.000
Area (User Defined)	999,266.400 ft ²
Maximum Retention (Pervious)	2.3 in
Maximum Retention (Pervious, 20 percent)	0.5 in
<hr/>	
Cumulative Runoff	
Cumulative Runoff Depth (Pervious)	1.6 in
Runoff Volume (Pervious)	136,048.354 ft ³
<hr/>	
Hydrograph Volume (Area under Hydrograph curve)	
Volume	136,031.000 ft ³
<hr/>	
SCS Unit Hydrograph Parameters	
Time of Concentration (Composite)	0.292 hours
Computational Time Increment	0.039 hours
Unit Hydrograph Shape Factor	483.432
K Factor	0.749
Receding/Rising, Tr/Tp	1.670

PROPOSED CONDITIONS

Subsection: Unit Hydrograph Summary
Label: Area B

Return Event: 2 years
Storm Event: TypeII 24hr (3.25 in)

SCS Unit Hydrograph Parameters	
Unit peak, qp	89.10 ft ³ /s
Unit peak time, Tp	0.194 hours
Unit receding limb, Tr	0.778 hours
Total unit time, Tb	0.972 hours

PROPOSED CONDITIONS

Subsection: Unit Hydrograph Summary
Label: Area B

Return Event: 10 years
Storm Event: TypeII 24hr (5.0 in)

Storm Event	TypeII 24hr (5.0 in)
Return Event	10 years
Duration	24.000 hours
Depth	5.0 in
Time of Concentration (Composite)	0.292 hours
Area (User Defined)	999,266.400 ft ²
<hr/>	
Computational Time Increment	0.039 hours
Time to Peak (Computed)	12.058 hours
Flow (Peak, Computed)	77.71 ft ³ /s
Output Increment	0.050 hours
Time to Flow (Peak Interpolated Output)	12.050 hours
Flow (Peak Interpolated Output)	77.04 ft ³ /s
<hr/>	
Drainage Area	
SCS CN (Composite)	81.000
Area (User Defined)	999,266.400 ft ²
Maximum Retention (Pervious)	2.3 in
Maximum Retention (Pervious, 20 percent)	0.5 in
<hr/>	
Cumulative Runoff	
Cumulative Runoff Depth (Pervious)	3.0 in
Runoff Volume (Pervious)	248,594.750 ft ³
<hr/>	
Hydrograph Volume (Area under Hydrograph curve)	
Volume	247,651.000 ft ³
<hr/>	
SCS Unit Hydrograph Parameters	
Time of Concentration (Composite)	0.292 hours
Computational Time Increment	0.039 hours
Unit Hydrograph Shape Factor	483.432
K Factor	0.749
Receding/Rising, Tr/Tp	1.670

PROPOSED CONDITIONS

Subsection: Unit Hydrograph Summary
Label: Area B

Return Event: 10 years
Storm Event: TypeII 24hr (5.0 in)

SCS Unit Hydrograph Parameters	
Unit peak, qp	89.10 ft ³ /s
Unit peak time, Tp	0.194 hours
Unit receding limb, Tr	0.778 hours
Total unit time, Tb	0.972 hours

PROPOSED CONDITIONS

Subsection: Unit Hydrograph Summary
 Label: Area B

Return Event: 100 years
 Storm Event: TypeII 24hr (8.0 in)

Storm Event	TypeII 24hr (8.0 in)
Return Event	100 years
Duration	35.000 hours
Depth	8.0 in
Time of Concentration (Composite)	0.292 hours
Area (User Defined)	999,266.400 ft ²

Computational Time Increment	0.039 hours
Time to Peak (Computed)	12.058 hours
Flow (Peak, Computed)	146.86 ft ³ /s
Output Increment	0.050 hours
Time to Flow (Peak Interpolated Output)	12.050 hours
Flow (Peak Interpolated Output)	145.91 ft ³ /s

Drainage Area	
SCS CN (Composite)	81.000
Area (User Defined)	999,266.400 ft ²
Maximum Retention (Pervious)	2.3 in
Maximum Retention (Pervious, 20 percent)	0.5 in

Cumulative Runoff	
Cumulative Runoff Depth (Pervious)	5.7 in
Runoff Volume (Pervious)	478,172.618 ft ³

Hydrograph Volume (Area under Hydrograph curve)	
Volume	478,172.000 ft ³

SCS Unit Hydrograph Parameters	
Time of Concentration (Composite)	0.292 hours
Computational Time Increment	0.039 hours
Unit Hydrograph Shape Factor	483.432
K Factor	0.749
Receding/Rising, Tr/Tp	1.670

PROPOSED CONDITIONS

Subsection: Unit Hydrograph Summary
Label: Area B

Return Event: 100 years
Storm Event: TypeII 24hr (8.0 in)

SCS Unit Hydrograph Parameters	
Unit peak, qp	89.10 ft ³ /s
Unit peak time, Tp	0.194 hours
Unit receding limb, Tr	0.778 hours
Total unit time, Tb	0.972 hours

PROPOSED CONDITIONS

Subsection: Unit Hydrograph Summary
 Label: BY-PASS

Return Event: 2 years
 Storm Event: TypeII 24hr (3.25 in)

Storm Event	TypeII 24hr (3.25 in)
Return Event	2 years
Duration	35.000 hours
Depth	3.4 in
Time of Concentration (Composite)	0.304 hours
Area (User Defined)	535,788.000 ft ²
<hr/>	
Computational Time Increment	0.100 hours
Time to Peak (Computed)	12.100 hours
Flow (Peak, Computed)	7.95 ft ³ /s
Output Increment	0.050 hours
Time to Flow (Peak Interpolated Output)	12.100 hours
Flow (Peak Interpolated Output)	7.95 ft ³ /s
<hr/>	
Drainage Area	
SCS CN (Composite)	67.000
Area (User Defined)	535,788.000 ft ²
Maximum Retention (Pervious)	4.9 in
Maximum Retention (Pervious, 20 percent)	1.0 in
<hr/>	
Cumulative Runoff	
Cumulative Runoff Depth (Pervious)	0.8 in
Runoff Volume (Pervious)	35,651.915 ft ³
<hr/>	
Hydrograph Volume (Area under Hydrograph curve)	
Volume	35,652.000 ft ³
<hr/>	
SCS Unit Hydrograph Parameters	
Time of Concentration (Composite)	0.304 hours
Computational Time Increment	0.100 hours
Unit Hydrograph Shape Factor	483.432
K Factor	0.749
Receding/Rising, Tr/Tp	1.670

PROPOSED CONDITIONS

Subsection: Unit Hydrograph Summary
Label: BY-PASS

Return Event: 2 years
Storm Event: TypeII 24hr (3.25 in)

SCS Unit Hydrograph Parameters	
Unit peak, qp	39.93 ft ³ /s
Unit peak time, Tp	0.233 hours
Unit receding limb, Tr	0.931 hours
Total unit time, Tb	1.163 hours

PROPOSED CONDITIONS

Subsection: Unit Hydrograph Summary
 Label: BY-PASS

Return Event: 10 years
 Storm Event: TypeII 24hr (5.0 in)

Storm Event	TypeII 24hr (5.0 in)
Return Event	10 years
Duration	24.000 hours
Depth	5.0 in
Time of Concentration (Composite)	0.304 hours
Area (User Defined)	535,788.000 ft ²
<hr/>	
Computational Time Increment	0.100 hours
Time to Peak (Computed)	12.100 hours
Flow (Peak, Computed)	22.70 ft ³ /s
Output Increment	0.050 hours
Time to Flow (Peak Interpolated Output)	12.100 hours
Flow (Peak Interpolated Output)	22.70 ft ³ /s
<hr/>	
Drainage Area	
SCS CN (Composite)	67.000
Area (User Defined)	535,788.000 ft ²
Maximum Retention (Pervious)	4.9 in
Maximum Retention (Pervious, 20 percent)	1.0 in
<hr/>	
Cumulative Runoff	
Cumulative Runoff Depth (Pervious)	1.8 in
Runoff Volume (Pervious)	80,503.483 ft ³
<hr/>	
Hydrograph Volume (Area under Hydrograph curve)	
Volume	80,070.000 ft ³
<hr/>	
SCS Unit Hydrograph Parameters	
Time of Concentration (Composite)	0.304 hours
Computational Time Increment	0.100 hours
Unit Hydrograph Shape Factor	483.432
K Factor	0.749
Receding/Rising, Tr/Tp	1.670

PROPOSED CONDITIONS

Subsection: Unit Hydrograph Summary
Label: BY-PASS

Return Event: 10 years
Storm Event: TypeII 24hr (5.0 in)

SCS Unit Hydrograph Parameters	
Unit peak, qp	39.93 ft ³ /s
Unit peak time, Tp	0.233 hours
Unit receding limb, Tr	0.931 hours
Total unit time, Tb	1.163 hours

PROPOSED CONDITIONS

Subsection: Unit Hydrograph Summary

Return Event: 100 years

Label: BY-PASS

Storm Event: TypeII 24hr (8.0 in)

Storm Event	TypeII 24hr (8.0 in)
Return Event	100 years
Duration	35.000 hours
Depth	8.0 in
Time of Concentration (Composite)	0.304 hours
Area (User Defined)	535,788.000 ft ²
<hr/>	
Computational Time Increment	0.100 hours
Time to Peak (Computed)	12.100 hours
Flow (Peak, Computed)	53.16 ft ³ /s
Output Increment	0.050 hours
Time to Flow (Peak Interpolated Output)	12.100 hours
Flow (Peak Interpolated Output)	53.16 ft ³ /s
<hr/>	
Drainage Area	
SCS CN (Composite)	67.000
Area (User Defined)	535,788.000 ft ²
Maximum Retention (Pervious)	4.9 in
Maximum Retention (Pervious, 20 percent)	1.0 in
<hr/>	
Cumulative Runoff	
Cumulative Runoff Depth (Pervious)	4.1 in
Runoff Volume (Pervious)	184,010.524 ft ³
<hr/>	
Hydrograph Volume (Area under Hydrograph curve)	
Volume	184,010.000 ft ³
<hr/>	
SCS Unit Hydrograph Parameters	
Time of Concentration (Composite)	0.304 hours
Computational Time Increment	0.100 hours
Unit Hydrograph Shape Factor	483.432
K Factor	0.749
Receding/Rising, Tr/Tp	1.670

PROPOSED CONDITIONS

Subsection: Unit Hydrograph Summary
Label: BY-PASS

Return Event: 100 years
Storm Event: TypeII 24hr (8.0 in)

SCS Unit Hydrograph Parameters	
Unit peak, qp	39.93 ft ³ /s
Unit peak time, Tp	0.233 hours
Unit receding limb, Tr	0.931 hours
Total unit time, Tb	1.163 hours

PROPOSED CONDITIONS

Subsection: Addition Summary
Label: O-14

Return Event: 2 years
Storm Event: TypeII 24hr (3.25 in)

Summary for Hydrograph Addition at 'O-14'

Upstream Link	Upstream Node
Outlet-A	Basin A
Outlet-B	Basin B
<Catchment to Outflow Node>	BY-PASS

Node Inflows

Inflow Type	Element	Volume (ft ³)	Time to Peak (hours)	Flow (Peak) (ft ³ /s)
Flow (From)	Outlet-A	129,060.939	12.350	11.64
Flow (From)	Outlet-B	136,031.020	12.250	22.40
Flow (From)	BY-PASS	35,651.896	12.100	7.95
Flow (In)	O-14	300,743.855	12.150	40.36

PROPOSED CONDITIONS

Subsection: Addition Summary

Label: O-14

Return Event: 10 years

Storm Event: TypeII 24hr (5.0 in)

Summary for Hydrograph Addition at 'O-14'

	Upstream Link	Upstream Node
Outlet-A		Basin A
Outlet-B		Basin B
<Catchment to Outflow Node>		BY-PASS

Node Inflows

Inflow Type	Element	Volume (ft ³)	Time to Peak (hours)	Flow (Peak) (ft ³ /s)
Flow (From)	Outlet-A	244,301.449	12.450	15.04
Flow (From)	Outlet-B	247,549.112	12.150	68.99
Flow (From)	BY-PASS	80,069.955	12.100	22.70
Flow (In)	O-14	571,920.516	12.150	103.30

PROPOSED CONDITIONS

Subsection: Addition Summary

Label: O-14

Return Event: 100 years

Storm Event: TypeII 24hr (8.0 in)

Summary for Hydrograph Addition at 'O-14'

Upstream Link	Upstream Node
Outlet-A	Basin A
Outlet-B	Basin B
<Catchment to Outflow Node>	BY-PASS

Node Inflows

Inflow Type	Element	Volume (ft ³)	Time to Peak (hours)	Flow (Peak) (ft ³ /s)
Flow (From)	Outlet-A	487,523.326	12.200	96.62
Flow (From)	Outlet-B	478,171.724	12.150	124.75
Flow (From)	BY-PASS	184,010.429	12.100	53.16
Flow (In)	O-14	1,149,705.479	12.150	267.04

PROPOSED CONDITIONS

Subsection: Elevation-Area Volume Curve

Return Event: 2 years

Label: Basin A

Storm Event: TypeII 24hr (3.25 in)

Elevation (ft)	Planimeter (ft ²)	Area (ft ²)	A1+A2+sq (A1*A2) (ft ²)	Volume (ft ³)	Volume (Total) (ft ³)
562.00	0.0	0.000	0.000	0.000	0.000
563.00	0.0	4,674.000	4,674.000	1,558.000	1,558.000
564.00	0.0	24,325.000	39,661.788	13,221.000	14,779.000
565.00	0.0	30,400.000	81,918.382	27,306.000	42,085.000
566.00	0.0	33,832.000	96,302.123	32,101.000	74,185.000
568.00	0.0	38,949.000	109,081.449	72,721.000	146,906.000
570.00	0.0	44,291.000	124,774.205	83,183.000	230,089.000

PROPOSED CONDITIONS

Subsection: Volume Equations

Return Event: 2 years

Label: Basin A

Storm Event: TypeII 24hr (3.25 in)

Pond Volume Equations

*** Incremental volume computed by the Conic Method for Reservoir Volumes.**

$$\text{Volume} = (1/3) * (\text{EL2} - \text{EL1}) * (\text{Area1} + \text{Area2} + \text{sqr}(\text{Area1} * \text{Area2}))$$

where: EL1, EL2 Lower and upper elevations of the increment
 Area1, Area2 Areas computed for EL1, EL2, respectively
 Volume Incremental volume between EL1 and EL2

PROPOSED CONDITIONS

Subsection: Elevation-Area Volume Curve

Return Event: 2 years

Label: Basin B

Storm Event: TypeII 24hr (3.25 in)

Elevation (ft)	Planimeter (ft ²)	Area (ft ²)	A1+A2+sqr (A1*A2) (ft ²)	Volume (ft ³)	Volume (Total) (ft ³)
541.00	0.0	0.000	0.000	0.000	0.000
542.00	0.0	2,500.000	2,500.000	833.000	833.000
543.00	0.0	3,919.000	9,549.096	3,183.000	4,016.000
544.00	0.0	12,854.000	23,870.523	7,957.000	11,973.000
545.00	0.0	16,922.000	44,524.403	14,841.000	26,815.000
546.00	0.0	21,025.000	56,809.265	18,936.000	45,751.000
548.00	0.0	24,911.000	68,821.667	45,881.000	91,632.000

PROPOSED CONDITIONS

Subsection: Volume Equations

Return Event: 2 years

Label: Basin B

Storm Event: TypeII 24hr (3.25 in)

Pond Volume Equations

*** Incremental volume computed by the Conic Method for Reservoir Volumes.**

$$\text{Volume} = (1/3) * (\text{EL2} - \text{EL1}) * (\text{Area1} + \text{Area2} + \text{sqr}(\text{Area1} * \text{Area2}))$$

where: EL1, EL2 Lower and upper elevations of the increment
 Area1, Area2 Areas computed for EL1, EL2, respectively
 Volume Incremental volume between EL1 and EL2

PROPOSED CONDITIONS

Subsection: Outlet Input Data

Return Event: 2 years

Label: Composite Outlet Structure - A

Storm Event: TypeII 24hr (3.25 in)

Requested Pond Water Surface Elevations	
Minimum (Headwater)	562.00 ft
Increment (Headwater)	0.10 ft
Maximum (Headwater)	570.00 ft

Outlet Connectivity

Structure Type	Outlet ID	Direction	Outfall	E1 (ft)	E2 (ft)
Rectangular Weir	Weir - 1	Forward	Culvert - 1	562.00	563.00
Orifice-Area	Orifice - 2	Forward	Culvert - 1	566.75	570.00
Rectangular Weir	Weir - 2	Forward	Culvert - 1	565.75	565.75
Inlet Box	Riser - 1	Forward	Culvert - 1	566.85	570.00
Orifice-Area	Orifice - 1	Forward	Culvert - 1	563.00	570.00
Culvert-Circular	Culvert - 1	Forward	TW	558.81	570.00
Tailwater Settings	Tailwater			(N/A)	(N/A)

PROPOSED CONDITIONS

Subsection: Outlet Input Data
 Label: Composite Outlet Structure - A

Return Event: 2 years
 Storm Event: TypeII 24hr (3.25 in)

Structure ID: Weir - 1	
Structure Type: Rectangular Weir	
Number of Openings	1
Elevation	562.00 ft
Weir Length	1.50 ft
Weir Coefficient	3.00 (ft ^{0.5})/s
Structure ID: Orifice - 1	
Structure Type: Orifice-Area	
Number of Openings	1
Elevation	562.00 ft
Orifice Area	1.5 ft ²
Top Elevation	0.00 ft
Datum Elevation	0.00 ft
Orifice Coefficient	0.600
Structure ID: Weir - 2	
Structure Type: Rectangular Weir	
Number of Openings	1
Elevation	565.75 ft
Weir Length	4.00 ft
Weir Coefficient	3.00 (ft ^{0.5})/s
Structure ID: Orifice - 2	
Structure Type: Orifice-Area	
Number of Openings	1
Elevation	565.75 ft
Orifice Area	4.0 ft ²
Top Elevation	0.00 ft
Datum Elevation	0.00 ft
Orifice Coefficient	0.600
Structure ID: Riser - 1	
Structure Type: Inlet Box	
Number of Openings	1
Elevation	566.85 ft
Orifice Area	36.0 ft ²
Orifice Coefficient	0.600
Weir Length	24.00 ft
Weir Coefficient	3.00 (ft ^{0.5})/s
K Reverse	1.000
Manning's n	0.000

PROPOSED CONDITIONS

Subsection: Outlet Input Data

Return Event: 2 years

Label: Composite Outlet Structure - A

Storm Event: TypeII 24hr (3.25 in)

Structure ID: Riser - 1	
Structure Type: Inlet Box	
Kev, Charged Riser	0.000
Weir Submergence	False
Orifice H to crest	False

Structure ID: Culvert - 1	
Structure Type: Culvert-Circular	
Number of Barrels	1
Diameter	36.0 In
Length	81.00 ft
Length (Computed Barrel)	81.00 ft
Slope (Computed)	0.010 ft/ft

Outlet Control Data	
Manning's n	0.013
Ke	0.000
Kb	0.007
Kr	0.000
Convergence Tolerance	0.00 ft

Inlet Control Data	
Equation Form	Form 2
K	0.5340
M	0.5550
C	0.0196
Y	0.9000
T1 ratio (HW/D)	1.070
T2 ratio (HW/D)	1.209
Slope Correction Factor	-0.500

Use unsubmerged inlet control 1 equation below T1 elevation.

Use submerged inlet control 1 equation above T2 elevation

In transition zone between unsubmerged and submerged inlet control, interpolate between flows at T1 & T2...

T1 Elevation	562.02 ft	T1 Flow	42.85 ft ³ /s
T2 Elevation	562.44 ft	T2 Flow	48.97 ft ³ /s

PROPOSED CONDITIONS

Subsection: Outlet Input Data

Return Event: 2 years

Label: Composite Outlet Structure - A

Storm Event: TypeII 24hr (3.25 in)

Structure ID: TW	
Structure Type: TW Setup, DS Channel	
Tailwater Type	Free Outfall
Convergence Tolerances	
Maximum Iterations	30
Tailwater Tolerance (Minimum)	0.01 ft
Tailwater Tolerance (Maximum)	0.50 ft
Headwater Tolerance (Minimum)	0.01 ft
Headwater Tolerance (Maximum)	0.50 ft
Flow Tolerance (Minimum)	0.001 ft ³ /s
Flow Tolerance (Maximum)	10.000 ft ³ /s

PROPOSED CONDITIONS

Subsection: Outlet Input Data

Return Event: 2 years

Label: Composite Outlet Structure - B

Storm Event: TypeII 24hr (3.25 in)

Requested Pond Water Surface Elevations

Minimum (Headwater)	541.00 ft
Increment (Headwater)	0.10 ft
Maximum (Headwater)	548.00 ft

Outlet Connectivity

Structure Type	Outlet ID	Direction	Outfall	E1 (ft)	E2 (ft)
Rectangular Weir	Weir - 1	Forward	Culvert - 1	541.00	542.00
Inlet Box	Riser - 1	Forward	Culvert - 1	544.50	548.00
Orifice-Area	Orifice - 1	Forward	Culvert - 1	542.00	548.00
Culvert-Circular	Culvert - 1	Forward	TW	539.94	548.00
Tailwater Settings	Tailwater			(N/A)	(N/A)

PROPOSED CONDITIONS

Subsection: Outlet Input Data

Return Event: 2 years

Label: Composite Outlet Structure - B

Storm Event: TypeII 24hr (3.25 in)

Structure ID: Weir - 1	
Structure Type: Rectangular Weir	
Number of Openings	1
Elevation	541.00 ft
Weir Length	3.00 ft
Weir Coefficient	3.00 (ft ^{0.5})/s
Structure ID: Orifice - 1	
Structure Type: Orifice-Area	
Number of Openings	1
Elevation	541.00 ft
Orifice Area	3.0 ft ²
Top Elevation	0.00 ft
Datum Elevation	0.00 ft
Orifice Coefficient	0.600
Structure ID: Riser - 1	
Structure Type: Inlet Box	
Number of Openings	1
Elevation	544.50 ft
Orifice Area	49.0 ft ²
Orifice Coefficient	0.600
Weir Length	28.00 ft
Weir Coefficient	3.00 (ft ^{0.5})/s
K Reverse	1.000
Manning's n	0.000
K _v , Charged Riser	0.000
Weir Submergence	False
Orifice H to crest	False
Structure ID: Culvert - 1	
Structure Type: Culvert-Circular	
Number of Barrels	1
Diameter	48.0 in
Length	389.00 ft
Length (Computed Barrel)	389.00 ft
Slope (Computed)	0.005 ft/ft
Outlet Control Data	
Manning's n	0.013
K _e	0.000
K _b	0.005

PROPOSED CONDITIONS

Subsection: Outlet Input Data
 Label: Composite Outlet Structure - B

Return Event: 2 years
 Storm Event: TypeII 24hr (3.25 in)

Outlet Control Data	
Kr	0.000
Convergence Tolerance	0.00 ft
Inlet Control Data	
Equation Form	Form 2
K	0.5340
M	0.5550
C	0.0196
Y	0.9000
T1 ratio (HW/D)	1.070
T2 ratio (HW/D)	1.211
Slope Correction Factor	-0.500

Use unsubmerged inlet control 1 equation below T1 elevation.
 Use submerged inlet control 1 equation above T2 elevation

In transition zone between unsubmerged and submerged inlet control, interpolate between flows at T1 & T2...

T1 Elevation	544.22 ft	T1 Flow	87.96 ft ³ /s
T2 Elevation	544.78 ft	T2 Flow	100.53 ft ³ /s

PROPOSED CONDITIONS

Subsection: Outlet Input Data

Return Event: 2 years

Label: Composite Outlet Structure - B

Storm Event: TypeII 24hr (3.25 in)

Structure ID: TW	
Structure Type: TW Setup, DS Channel	
Tailwater Type	Free Outfall
Convergence Tolerances	
Maximum Iterations	30
Tailwater Tolerance (Minimum)	0.01 ft
Tailwater Tolerance (Maximum)	0.50 ft
Headwater Tolerance (Minimum)	0.01 ft
Headwater Tolerance (Maximum)	0.50 ft
Flow Tolerance (Minimum)	0.001 ft ³ /s
Flow Tolerance (Maximum)	10.000 ft ³ /s

PROPOSED CONDITIONS

Subsection: Elevation-Volume-Flow Table (Pond)

Return Event: 2 years

Label: Basin A

Storm Event: TypeII 24hr (3.25 in)

Infiltration	
Infiltration Method (Computed)	No Infiltration

Initial Conditions	
Elevation (Water Surface, Initial)	562.00 ft
Volume (Initial)	0.000 ft ³
Flow (Initial Outlet)	0.00 ft ³ /s
Flow (Initial Infiltration)	0.00 ft ³ /s
Flow (Initial, Total)	0.00 ft ³ /s
Time Increment	0.050 hours

Elevation (ft)	Outflow (ft ³ /s)	Storage (ft ³)	Area (ft ²)	Infiltration (ft ³ /s)	Flow (Total) (ft ³ /s)	2S/t + O (ft ³ /s)
562.00	0.00	0.000	0.000	0.00	0.00	0.00
562.10	0.14	1.558	46.740	0.00	0.14	0.16
562.20	0.40	12.464	186.960	0.00	0.40	0.54
562.30	0.74	42.066	420.660	0.00	0.74	1.21
562.40	1.14	99.712	747.840	0.00	1.14	2.25
562.50	1.59	194.750	1,168.500	0.00	1.59	3.75
562.60	2.09	336.528	1,682.640	0.00	2.09	5.83
562.70	2.63	534.394	2,290.260	0.00	2.63	8.57
562.80	3.22	797.696	2,991.360	0.00	3.22	12.08
562.90	3.84	1,135.782	3,785.940	0.00	3.84	16.46
563.00	7.22	1,558.000	4,674.000	0.00	7.22	24.54
563.10	7.57	2,087.846	5,948.492	0.00	7.57	30.77
563.20	7.92	2,752.814	7,376.452	0.00	7.92	38.50
563.30	8.23	3,568.252	8,957.881	0.00	8.23	47.87
563.40	8.54	4,549.506	10,692.778	0.00	8.54	59.09
563.50	8.85	5,711.923	12,581.144	0.00	8.85	72.31
563.60	9.13	7,070.850	14,622.978	0.00	9.13	87.70
563.70	9.42	8,641.634	16,818.281	0.00	9.42	105.44
563.80	9.68	10,439.622	19,167.052	0.00	9.68	125.68
563.90	9.94	12,480.160	21,669.292	0.00	9.94	148.61
564.00	10.20	14,778.596	24,325.000	0.00	10.20	174.41
564.10	10.47	17,239.893	24,902.059	0.00	10.47	202.02
564.20	10.70	19,759.233	25,485.882	0.00	10.70	230.25
564.30	10.94	22,337.295	26,076.470	0.00	10.94	259.14
564.40	11.18	24,974.753	26,673.823	0.00	11.18	288.68
564.50	11.42	27,672.285	27,277.941	0.00	11.42	318.88
564.60	11.64	30,430.566	27,888.823	0.00	11.64	349.76
564.70	11.86	33,250.275	28,506.470	0.00	11.86	381.31
564.80	12.08	36,132.086	29,130.882	0.00	12.08	413.55

PROPOSED CONDITIONS

Subsection: Elevation-Volume-Flow Table (Pond)

Return Event: 2 years

Label: Basin A

Storm Event: TypeII 24hr (3.25 in)

Elevation (ft)	Outflow (ft ³ /s)	Storage (ft ³)	Area (ft ²)	Infiltration (ft ³ /s)	Flow (Total) (ft ³ /s)	2S/t + O (ft ³ /s)
564.90	12.29	39,076.677	29,762.059	0.00	12.29	446.48
565.00	12.50	42,084.723	30,400.000	0.00	12.50	480.11
565.10	12.71	45,141.455	30,734.942	0.00	12.71	514.28
565.20	12.91	48,231.773	31,071.719	0.00	12.91	548.82
565.30	13.11	51,355.860	31,410.332	0.00	13.11	583.74
565.40	13.31	54,513.900	31,750.779	0.00	13.31	619.02
565.50	13.51	57,706.077	32,093.062	0.00	13.51	654.69
565.60	13.70	60,932.574	32,437.179	0.00	13.70	690.73
565.70	13.89	64,193.574	32,783.132	0.00	13.89	727.15
565.75	13.98	65,837.070	32,956.796	0.00	13.98	745.50
565.80	14.07	67,489.261	33,130.919	0.00	14.07	763.95
565.90	14.26	70,819.819	33,480.542	0.00	14.26	801.14
566.00	14.44	74,185.431	33,832.000	0.00	14.44	838.72
566.10	14.62	77,580.988	34,079.295	0.00	14.62	876.63
566.20	14.80	81,001.320	34,327.491	0.00	14.80	914.81
566.30	14.97	84,446.516	34,576.587	0.00	14.97	953.27
566.40	15.14	87,916.667	34,826.584	0.00	15.14	992.00
566.50	15.31	91,411.863	35,077.481	0.00	15.31	1,031.00
566.60	15.48	94,932.194	35,329.278	0.00	15.48	1,070.29
566.70	15.65	98,477.749	35,581.977	0.00	15.65	1,109.85
566.80	35.52	102,048.619	35,835.575	0.00	35.52	1,169.40
566.85	36.10	103,843.575	35,962.712	0.00	36.10	1,189.91
566.90	37.43	105,644.894	36,090.075	0.00	37.43	1,211.26
567.00	41.82	109,266.664	36,345.474	0.00	41.82	1,255.89
567.10	47.12	112,914.019	36,601.775	0.00	47.12	1,301.72
567.20	53.50	116,587.049	36,858.975	0.00	53.50	1,348.91
567.30	60.75	120,285.844	37,117.077	0.00	60.75	1,397.26
567.40	68.62	124,010.494	37,376.078	0.00	68.62	1,446.51
567.50	76.99	127,761.090	37,635.981	0.00	76.99	1,496.55
567.60	85.54	131,537.720	37,896.784	0.00	85.54	1,547.07
567.70	94.33	135,340.476	38,158.487	0.00	94.33	1,598.11
567.80	101.62	139,169.448	38,421.091	0.00	101.62	1,647.94
567.90	107.16	143,024.724	38,684.595	0.00	107.16	1,696.32
568.00	112.37	146,906.397	38,949.000	0.00	112.37	1,744.66
568.10	116.92	150,814.237	39,207.949	0.00	116.92	1,792.64
568.20	120.33	154,748.015	39,467.757	0.00	120.33	1,839.75
568.30	121.82	158,707.817	39,728.422	0.00	121.82	1,885.24
568.40	122.64	162,693.728	39,989.945	0.00	122.64	1,930.35
568.50	123.45	166,705.835	40,252.327	0.00	123.45	1,975.74
568.60	124.27	170,744.222	40,515.566	0.00	124.27	2,021.43
568.70	125.08	174,808.976	40,779.663	0.00	125.08	2,067.40
568.80	125.89	178,900.183	41,044.618	0.00	125.89	2,113.67
568.90	126.68	183,017.929	41,310.431	0.00	126.68	2,160.22

PROPOSED CONDITIONS

Subsection: Elevation-Volume-Flow Table (Pond)

Return Event: 2 years

Label: Basin A

Storm Event: TypeII 24hr (3.25 in)

Elevation (ft)	Outflow (ft ³ /s)	Storage (ft ³)	Area (ft ²)	Infiltration (ft ³ /s)	Flow (Total) (ft ³ /s)	2S/t + O (ft ³ /s)
569.00	127.48	187,162.298	41,577.102	0.00	127.48	2,207.06
569.10	128.27	191,333.378	41,844.631	0.00	128.27	2,254.20
569.20	129.06	195,531.253	42,113.018	0.00	129.06	2,301.63
569.30	129.84	199,756.010	42,382.263	0.00	129.84	2,349.35
569.40	130.60	204,007.734	42,652.366	0.00	130.60	2,397.36
569.50	131.39	208,286.512	42,923.327	0.00	131.39	2,445.68
569.60	132.16	212,592.428	43,195.145	0.00	132.16	2,494.30
569.70	132.92	216,925.570	43,467.822	0.00	132.92	2,543.20
569.80	133.68	221,286.021	43,741.357	0.00	133.68	2,592.41
569.90	134.41	225,673.869	44,015.749	0.00	134.41	2,641.89
570.00	135.15	230,089.200	44,291.000	0.00	135.15	2,691.70

PROPOSED CONDITIONS

Subsection: Level Pool Pond Routing Summary
 Label: Basin A (IN)

Return Event: 2 years
 Storm Event: TypeII 24hr (3.25 in)

Infiltration			
Infiltration Method (Computed)	No Infiltration		
Initial Conditions			
Elevation (Water Surface, Initial)	562.00 ft		
Volume (Initial)	0.000 ft ³		
Flow (Initial Outlet)	0.00 ft ³ /s		
Flow (Initial Infiltration)	0.00 ft ³ /s		
Flow (Initial, Total)	0.00 ft ³ /s		
Time Increment	0.050 hours		
Inflow/Outflow Hydrograph Summary			
Flow (Peak In)	39.59 ft ³ /s	Time to Peak (Flow, In)	12.050 hours
Flow (Peak Outlet)	11.64 ft ³ /s	Time to Peak (Flow, Outlet)	12.350 hours
Peak Conditions			
Elevation (Water Surface, Peak)	564.60 ft		
Volume (Peak)	30,406.647 ft ³		
Mass Balance (ft ³)			
Volume (Initial)	0.000 ft ³		
Volume (Total Inflow)	129,061.000 ft ³		
Volume (Total Infiltration)	0.000 ft ³		
Volume (Total Outlet Outflow)	129,061.000 ft ³		
Volume (Retained)	0.000 ft ³		
Volume (Unrouted)	0.000 ft ³		
Error (Mass Balance)	0.0 %		

PROPOSED CONDITIONS

Subsection: Level Pool Pond Routing Summary
 Label: Basin A (IN)

Return Event: 10 years
 Storm Event: TypeII 24hr (5.0 in)

Infiltration			
Infiltration Method (Computed)	No Infiltration		
Initial Conditions			
Elevation (Water Surface, Initial)	562.00 ft		
Volume (Initial)	0.000 ft ³		
Flow (Initial Outlet)	0.00 ft ³ /s		
Flow (Initial Infiltration)	0.00 ft ³ /s		
Flow (Initial, Total)	0.00 ft ³ /s		
Time Increment	0.050 hours		
Inflow/Outflow Hydrograph Summary			
Flow (Peak In)	82.55 ft ³ /s	Time to Peak (Flow, In)	12.050 hours
Flow (Peak Outlet)	15.04 ft ³ /s	Time to Peak (Flow, Outlet)	12.450 hours
Peak Conditions			
Elevation (Water Surface, Peak)	566.34 ft		
Volume (Peak)	85,826.848 ft ³		
Mass Balance (ft ³)			
Volume (Initial)	0.000 ft ³		
Volume (Total Inflow)	244,411.000 ft ³		
Volume (Total Infiltration)	0.000 ft ³		
Volume (Total Outlet Outflow)	244,301.000 ft ³		
Volume (Retained)	0.000 ft ³		
Volume (Unrouted)	-110.000 ft ³		
Error (Mass Balance)	0.0 %		

PROPOSED CONDITIONS

Subsection: Level Pool Pond Routing Summary
 Label: Basin A (IN)

Return Event: 100 years
 Storm Event: TypeII 24hr (8.0 in)

Infiltration			
Infiltration Method (Computed)	No Infiltration		
Initial Conditions			
Elevation (Water Surface, Initial)	562.00 ft		
Volume (Initial)	0.000 ft ³		
Flow (Initial Outlet)	0.00 ft ³ /s		
Flow (Initial Infiltration)	0.00 ft ³ /s		
Flow (Initial, Total)	0.00 ft ³ /s		
Time Increment	0.050 hours		
Inflow/Outflow Hydrograph Summary			
Flow (Peak In)	161.04 ft ³ /s	Time to Peak (Flow, In)	12.050 hours
Flow (Peak Outlet)	96.62 ft ³ /s	Time to Peak (Flow, Outlet)	12.200 hours
Elevation (Water Surface, Peak)	567.73 ft		
Volume (Peak)	136,541.012 ft ³		
Mass Balance (ft ³)			
Volume (Initial)	0.000 ft ³		
Volume (Total Inflow)	487,523.000 ft ³		
Volume (Total Infiltration)	0.000 ft ³		
Volume (Total Outlet Outflow)	487,523.000 ft ³		
Volume (Retained)	0.000 ft ³		
Volume (Unrouted)	0.000 ft ³		
Error (Mass Balance)	0.0 %		

PROPOSED CONDITIONS

Subsection: Pond Routed Hydrograph (total out)
 Label: Basin A (OUT)

Return Event: 2 years
 Storm Event: TypeII 24hr (3.25 in)

Peak Discharge	11.64 ft ³ /s
Time to Peak	12.350 hours
Hydrograph Volume	129,060.855 ft ³

HYDROGRAPH ORDINATES (ft³/s) Output Time Increment = 0.050 hours

Time on left represents time for first value in each row.

Time (hours)	Flow (ft ³ /s)	Flow (ft ³ /s)	Flow (ft ³ /s)	Flow (ft ³ /s)	Flow (ft ³ /s)
9.900	0.00	0.00	0.01	0.02	0.03
10.150	0.04	0.05	0.07	0.09	0.11
10.400	0.13	0.15	0.17	0.20	0.22
10.650	0.25	0.28	0.31	0.35	0.39
10.900	0.43	0.48	0.52	0.57	0.63
11.150	0.69	0.76	0.85	0.94	1.04
11.400	1.16	1.23	1.34	1.49	1.73
11.650	2.14	2.77	3.66	7.24	7.77
11.900	8.47	9.21	9.86	10.43	10.90
12.150	11.25	11.47	11.58	11.63	11.64
12.400	11.62	11.57	11.52	11.45	11.37
12.650	11.28	11.18	11.08	10.97	10.86
12.900	10.75	10.63	10.52	10.39	10.26
13.150	10.13	9.99	9.84	9.69	9.52
13.400	9.33	9.13	8.89	8.62	8.31
13.650	7.95	7.46	4.87	3.51	3.19
13.900	2.91	2.71	2.54	2.41	2.31
14.150	2.23	2.17	2.12	2.07	2.03
14.400	2.00	1.98	1.96	1.94	1.92
14.650	1.90	1.88	1.86	1.85	1.83
14.900	1.81	1.79	1.78	1.76	1.74
15.150	1.72	1.70	1.69	1.67	1.65
15.400	1.63	1.61	1.60	1.57	1.55
15.650	1.53	1.51	1.50	1.48	1.46
15.900	1.44	1.42	1.40	1.38	1.36
16.150	1.35	1.33	1.32	1.31	1.30
16.400	1.29	1.28	1.28	1.27	1.26
16.650	1.26	1.25	1.24	1.24	1.23
16.900	1.22	1.22	1.21	1.21	1.20
17.150	1.19	1.18	1.18	1.17	1.17
17.400	1.16	1.15	1.14	1.13	1.13
17.650	1.12	1.11	1.11	1.10	1.09
17.900	1.09	1.08	1.07	1.07	1.06
18.150	1.05	1.05	1.04	1.03	1.03
18.400	1.02	1.01	1.01	1.00	0.99
18.650	0.99	0.98	0.97	0.97	0.96
18.900	0.95	0.94	0.94	0.93	0.92

PROPOSED CONDITIONS

Subsection: Pond Routed Hydrograph (total out)

Return Event: 2 years

Label: Basin A (OUT)

Storm Event: TypeII 24hr (3.25 in)

HYDROGRAPH ORDINATES (ft³/s)

Output Time Increment = 0.050 hours

Time on left represents time for first value in each row.

Time (hours)	Flow (ft ³ /s)	Flow (ft ³ /s)	Flow (ft ³ /s)	Flow (ft ³ /s)	Flow (ft ³ /s)
19.150	0.92	0.91	0.90	0.90	0.89
19.400	0.88	0.87	0.87	0.86	0.85
19.650	0.85	0.84	0.83	0.83	0.82
19.900	0.81	0.80	0.80	0.79	0.78
20.150	0.78	0.77	0.77	0.77	0.76
20.400	0.76	0.76	0.76	0.76	0.76
20.650	0.76	0.75	0.75	0.75	0.75
20.900	0.75	0.75	0.75	0.75	0.74
21.150	0.74	0.74	0.74	0.74	0.74
21.400	0.74	0.74	0.73	0.73	0.73
21.650	0.73	0.73	0.73	0.73	0.72
21.900	0.72	0.72	0.72	0.72	0.72
22.150	0.72	0.72	0.71	0.71	0.71
22.400	0.71	0.71	0.71	0.71	0.71
22.650	0.70	0.70	0.70	0.70	0.70
22.900	0.70	0.70	0.69	0.69	0.69
23.150	0.69	0.69	0.69	0.69	0.69
23.400	0.68	0.68	0.68	0.68	0.68
23.650	0.68	0.68	0.68	0.67	0.67
23.900	0.68	1.24	2.48	5.21	7.71
24.150	8.07	8.16	8.02	7.66	6.10
24.400	3.25	2.39	1.52	0.53	0.17
24.650	0.11	0.06	0.02	0.00	0.00

PROPOSED CONDITIONS

Subsection: Pond Routed Hydrograph (total out)
 Label: Basin A (OUT)

Return Event: 10 years
 Storm Event: TypeII 24hr (5.0 in)

Peak Discharge	15.04 ft ³ /s
Time to Peak	12.450 hours
Hydrograph Volume	244,301.412 ft ³

HYDROGRAPH ORDINATES (ft³/s) Output Time Increment = 0.050 hours

Time on left represents time for first value in each row.

Time (hours)	Flow (ft ³ /s)	Flow (ft ³ /s)	Flow (ft ³ /s)	Flow (ft ³ /s)	Flow (ft ³ /s)
7.750	0.00	0.00	0.00	0.01	0.02
8.000	0.03	0.04	0.05	0.06	0.07
8.250	0.08	0.09	0.10	0.12	0.13
8.500	0.15	0.17	0.18	0.20	0.22
8.750	0.24	0.26	0.28	0.30	0.32
9.000	0.34	0.36	0.39	0.41	0.43
9.250	0.45	0.48	0.49	0.51	0.53
9.500	0.55	0.57	0.59	0.61	0.64
9.750	0.66	0.70	0.73	0.77	0.80
10.000	0.84	0.88	0.93	0.97	1.02
10.250	1.07	1.13	1.18	1.22	1.28
10.500	1.34	1.41	1.48	1.55	1.63
10.750	1.70	1.79	1.89	2.00	2.11
11.000	2.21	2.32	2.44	2.58	2.72
11.250	2.88	3.07	3.28	3.49	3.72
11.500	4.27	4.97	5.83	7.26	7.64
11.750	8.23	8.91	9.60	10.33	11.16
12.000	12.06	12.91	13.64	14.18	14.54
12.250	14.77	14.90	14.98	15.02	15.04
12.500	15.04	15.02	14.99	14.95	14.90
12.750	14.84	14.78	14.72	14.66	14.59
13.000	14.52	14.45	14.37	14.29	14.21
13.250	14.13	14.05	13.97	13.88	13.79
13.500	13.70	13.61	13.52	13.43	13.33
13.750	13.24	13.14	13.04	12.94	12.84
14.000	12.74	12.63	12.53	12.42	12.31
14.250	12.20	12.09	11.98	11.87	11.75
14.500	11.64	11.52	11.40	11.28	11.15
14.750	11.03	10.90	10.78	10.65	10.53
15.000	10.40	10.26	10.12	9.98	9.82
15.250	9.66	9.49	9.30	9.09	8.86
15.500	8.58	8.27	7.92	7.44	4.87
15.750	3.57	3.31	3.10	2.93	2.81
16.000	2.71	2.64	2.56	2.51	2.47
16.250	2.43	2.40	2.38	2.36	2.34
16.500	2.33	2.31	2.30	2.29	2.27
16.750	2.26	2.25	2.24	2.22	2.21

PROPOSED CONDITIONS

Subsection: Pond Routed Hydrograph (total out)
 Label: Basin A (OUT)

Return Event: 10 years
 Storm Event: TypeII 24hr (5.0 in)

HYDROGRAPH ORDINATES (ft³/s) Output Time Increment = 0.050 hours

Time on left represents time for first value in each row.

Time (hours)	Flow (ft ³ /s)	Flow (ft ³ /s)	Flow (ft ³ /s)	Flow (ft ³ /s)	Flow (ft ³ /s)
17.000	2.20	2.19	2.17	2.16	2.15
17.250	2.14	2.13	2.11	2.10	2.09
17.500	2.07	2.06	2.05	2.03	2.02
17.750	2.01	2.00	1.98	1.97	1.96
18.000	1.95	1.93	1.92	1.91	1.90
18.250	1.88	1.87	1.86	1.85	1.83
18.500	1.82	1.81	1.80	1.78	1.77
18.750	1.76	1.75	1.73	1.72	1.71
19.000	1.69	1.68	1.67	1.66	1.64
19.250	1.63	1.62	1.61	1.59	1.58
19.500	1.56	1.55	1.54	1.52	1.51
19.750	1.50	1.48	1.47	1.46	1.45
20.000	1.43	1.42	1.41	1.40	1.39
20.250	1.38	1.37	1.37	1.36	1.36
20.500	1.36	1.35	1.35	1.35	1.35
20.750	1.34	1.34	1.34	1.34	1.34
21.000	1.33	1.33	1.33	1.33	1.32
21.250	1.32	1.32	1.32	1.31	1.31
21.500	1.31	1.31	1.30	1.30	1.30
21.750	1.30	1.29	1.29	1.29	1.29
22.000	1.28	1.28	1.28	1.28	1.27
22.250	1.27	1.27	1.27	1.26	1.26
22.500	1.26	1.26	1.25	1.25	1.25
22.750	1.25	1.24	1.24	1.24	1.24
23.000	1.24	1.23	1.23	1.23	1.23
23.250	1.22	1.22	1.22	1.22	1.21
23.500	1.21	1.21	1.21	1.20	1.20
23.750	1.20	1.20	1.19	1.19	1.19
24.000	1.19	(N/A)	(N/A)	(N/A)	(N/A)

PROPOSED CONDITIONS

Subsection: Pond Routed Hydrograph (total out)
 Label: Basin A (OUT)

Return Event: 100 years
 Storm Event: TypeII 24hr (8.0 in)

Peak Discharge	96.62 ft ³ /s
Time to Peak	12.200 hours
Hydrograph Volume	487,523.203 ft ³

HYDROGRAPH ORDINATES (ft³/s) Output Time Increment = 0.050 hours

Time on left represents time for first value in each row.

Time (hours)	Flow (ft ³ /s)	Flow (ft ³ /s)	Flow (ft ³ /s)	Flow (ft ³ /s)	Flow (ft ³ /s)
5.550	0.00	0.00	0.01	0.02	0.03
5.800	0.05	0.06	0.08	0.09	0.11
6.050	0.13	0.15	0.16	0.18	0.20
6.300	0.22	0.24	0.25	0.27	0.29
6.550	0.31	0.33	0.35	0.37	0.39
6.800	0.41	0.43	0.45	0.47	0.49
7.050	0.51	0.53	0.55	0.57	0.59
7.300	0.61	0.64	0.66	0.68	0.70
7.550	0.72	0.74	0.76	0.79	0.81
7.800	0.83	0.85	0.88	0.90	0.92
8.050	0.95	0.97	1.00	1.03	1.06
8.300	1.10	1.14	1.18	1.21	1.25
8.550	1.30	1.35	1.40	1.45	1.50
8.800	1.55	1.61	1.65	1.70	1.76
9.050	1.82	1.88	1.93	1.99	2.04
9.300	2.08	2.12	2.15	2.18	2.21
9.550	2.25	2.28	2.32	2.36	2.41
9.800	2.48	2.55	2.63	2.70	2.78
10.050	2.86	2.96	3.06	3.16	3.27
10.300	3.37	3.49	3.61	3.75	3.97
10.550	4.33	4.53	4.72	4.92	5.14
10.800	5.37	5.62	5.88	6.15	6.42
11.050	6.71	7.03	7.25	7.32	7.43
11.300	7.60	7.77	7.96	8.16	8.35
11.550	8.58	8.85	9.20	9.66	10.22
11.800	10.90	11.76	12.79	13.98	15.23
12.050	46.97	79.31	95.74	96.62	89.02
12.300	77.63	66.53	57.17	49.77	44.14
12.550	39.80	36.62	33.48	22.76	18.36
12.800	16.28	15.64	15.63	15.61	15.59
13.050	15.56	15.53	15.50	15.46	15.42
13.300	15.38	15.34	15.29	15.24	15.19
13.550	15.14	15.08	15.03	14.97	14.91
13.800	14.85	14.79	14.72	14.66	14.59
14.050	14.52	14.45	14.38	14.30	14.23
14.300	14.15	14.08	14.00	13.93	13.85
14.550	13.77	13.69	13.61	13.53	13.45

PROPOSED CONDITIONS

Subsection: Pond Routed Hydrograph (total out)
 Label: Basin A (OUT)

Return Event: 100 years
 Storm Event: TypeII 24hr (8.0 in)

HYDROGRAPH ORDINATES (ft³/s) Output Time Increment = 0.050 hours

Time on left represents time for first value in each row.

Time (hours)	Flow (ft ³ /s)	Flow (ft ³ /s)	Flow (ft ³ /s)	Flow (ft ³ /s)	Flow (ft ³ /s)
14.800	13.37	13.28	13.20	13.12	13.03
15.050	12.95	12.86	12.78	12.69	12.60
15.300	12.51	12.42	12.33	12.24	12.15
15.550	12.06	11.96	11.87	11.77	11.67
15.800	11.57	11.47	11.36	11.26	11.15
16.050	11.04	10.93	10.83	10.72	10.61
16.300	10.50	10.38	10.26	10.14	10.02
16.550	9.89	9.76	9.62	9.47	9.31
16.800	9.13	8.94	8.73	8.50	8.24
17.050	7.95	7.59	6.84	4.26	3.84
17.300	3.80	3.77	3.74	3.72	3.69
17.550	3.67	3.64	3.62	3.60	3.57
17.800	3.55	3.53	3.51	3.48	3.46
18.050	3.44	3.42	3.39	3.37	3.35
18.300	3.33	3.30	3.28	3.26	3.24
18.550	3.21	3.19	3.16	3.14	3.11
18.800	3.09	3.07	3.04	3.02	3.00
19.050	2.98	2.95	2.93	2.91	2.88
19.300	2.86	2.84	2.82	2.79	2.77
19.550	2.75	2.73	2.70	2.68	2.66
19.800	2.63	2.61	2.58	2.56	2.53
20.050	2.51	2.49	2.47	2.45	2.43
20.300	2.42	2.41	2.40	2.39	2.38
20.550	2.38	2.37	2.37	2.36	2.36
20.800	2.35	2.35	2.35	2.34	2.34
21.050	2.33	2.33	2.32	2.32	2.31
21.300	2.31	2.31	2.30	2.30	2.29
21.550	2.29	2.28	2.28	2.27	2.27
21.800	2.27	2.26	2.26	2.25	2.25
22.050	2.24	2.24	2.23	2.23	2.23
22.300	2.22	2.22	2.21	2.21	2.20
22.550	2.20	2.19	2.19	2.19	2.18
22.800	2.18	2.17	2.17	2.16	2.16
23.050	2.15	2.15	2.15	2.14	2.14
23.300	2.13	2.13	2.12	2.12	2.11
23.550	2.11	2.11	2.10	2.10	2.09
23.800	2.09	2.08	2.08	2.07	2.07
24.050	2.04	1.94	1.71	1.32	0.74
24.300	0.38	0.23	0.14	0.08	0.05
24.550	0.03	0.02	0.01	0.00	0.00
24.800	0.00	(N/A)	(N/A)	(N/A)	(N/A)

PROPOSED CONDITIONS

Subsection: Pond Inflow Summary
Label: Basin A (IN)

Return Event: 2 years
Storm Event: TypeII 24hr (3.25 in)

Summary for Hydrograph Addition at 'Basin A'

Upstream Link	Upstream Node
<Catchment to Outflow Node>	Area A

Node Inflows

Inflow Type	Element	Volume (ft ³)	Time to Peak (hours)	Flow (Peak) (ft ³ /s)
Flow (From)	Area A	129,060.939	12.050	39.59
Flow (In)	Basin A	129,060.939	12.050	39.59

PROPOSED CONDITIONS

Subsection: Pond Inflow Summary
Label: Basin A (IN)

Return Event: 10 years
Storm Event: TypeII 24hr (5.0 in)

Summary for Hydrograph Addition at 'Basin A'

Upstream Link	Upstream Node
<Catchment to Outflow Node>	Area A

Node Inflows

Inflow Type	Element	Volume (ft ³)	Time to Peak (hours)	Flow (Peak) (ft ³ /s)
Flow (From)	Area A	244,411.010	12.050	82.55
Flow (In)	Basin A	244,411.010	12.050	82.55

PROPOSED CONDITIONS

Subsection: Pond Inflow Summary

Return Event: 100 years

Label: Basin A (IN)

Storm Event: TypeII 24hr (8.0 in)

Summary for Hydrograph Addition at 'Basin A'

Upstream Link	Upstream Node
<Catchment to Outflow Node>	Area A

Node Inflows

Inflow Type	Element	Volume (ft ³)	Time to Peak (hours)	Flow (Peak) (ft ³ /s)
Flow (From)	Area A	487,523.326	12.050	161.04
Flow (In)	Basin A	487,523.326	12.050	161.04

PROPOSED CONDITIONS

Subsection: Elevation-Volume-Flow Table (Pond)
 Label: Basin B

Return Event: 2 years
 Storm Event: TypeII 24hr (3.25 in)

Infiltration	
Infiltration Method (Computed)	No Infiltration
Initial Conditions	
Elevation (Water Surface, Initial)	541.00 ft
Volume (Initial)	0.000 ft ³
Flow (Initial Outlet)	0.00 ft ³ /s
Flow (Initial Infiltration)	0.00 ft ³ /s
Flow (Initial, Total)	0.00 ft ³ /s
Time Increment	0.050 hours

Elevation (ft)	Outflow (ft ³ /s)	Storage (ft ³)	Area (ft ²)	Infiltration (ft ³ /s)	Flow (Total) (ft ³ /s)	2S/t + O (ft ³ /s)
541.00	0.00	0.000	0.000	0.00	0.00	0.00
541.10	0.28	0.833	25.000	0.00	0.28	0.29
541.20	0.80	6.667	100.000	0.00	0.80	0.88
541.30	1.48	22.500	225.000	0.00	1.48	1.73
541.40	2.27	53.333	400.000	0.00	2.27	2.87
541.50	3.18	104.167	625.000	0.00	3.18	4.34
541.60	4.18	180.000	900.000	0.00	4.18	6.18
541.70	5.27	285.833	1,225.000	0.00	5.27	8.44
541.80	6.44	426.667	1,600.000	0.00	6.44	11.18
541.90	7.65	607.500	2,025.000	0.00	7.65	14.40
542.00	11.68	833.333	2,500.000	0.00	11.68	20.94
542.10	12.27	1,089.687	2,627.607	0.00	12.27	24.38
542.20	12.81	1,358.961	2,758.391	0.00	12.81	27.90
542.30	13.33	1,641.471	2,892.350	0.00	13.33	31.57
542.40	13.84	1,937.537	3,029.486	0.00	13.84	35.37
542.50	14.35	2,247.474	3,169.798	0.00	14.35	39.32
542.60	14.84	2,571.602	3,313.286	0.00	14.84	43.42
542.70	15.33	2,910.237	3,459.950	0.00	15.33	47.66
542.80	15.84	3,263.698	3,609.791	0.00	15.84	52.10
542.90	16.31	3,632.301	3,762.807	0.00	16.31	56.66
543.00	16.77	4,016.365	3,919.000	0.00	16.77	61.39
543.10	17.22	4,440.910	4,580.484	0.00	17.22	66.57
543.20	17.67	4,934.181	5,293.527	0.00	17.67	72.49
543.30	18.11	5,501.334	6,058.129	0.00	18.11	79.23
543.40	18.54	6,147.525	6,874.291	0.00	18.54	86.85
543.50	18.96	6,877.911	7,742.011	0.00	18.96	95.39
543.60	19.38	7,697.646	8,661.291	0.00	19.38	104.91
543.70	19.80	8,611.888	9,632.129	0.00	19.80	115.49
543.80	20.22	9,625.791	10,654.527	0.00	20.22	127.17

PROPOSED CONDITIONS

Subsection: Elevation-Volume-Flow Table (Pond)

Return Event: 2 years

Label: Basin B

Storm Event: TypeII 24hr (3.25 in)

Elevation (ft)	Outflow (ft ³ /s)	Storage (ft ³)	Area (ft ²)	Infiltration (ft ³ /s)	Flow (Total) (ft ³ /s)	2S/t + O (ft ³ /s)
543.90	20.63	10,744.512	11,728.484	0.00	20.63	140.01
544.00	21.01	11,973.206	12,854.000	0.00	21.01	154.04
544.10	21.42	13,277.643	13,235.673	0.00	21.42	168.95
544.20	21.80	14,620.527	13,622.929	0.00	21.80	184.25
544.30	22.18	16,002.415	14,015.769	0.00	22.18	199.98
544.40	22.55	17,423.867	14,414.193	0.00	22.55	216.15
544.50	22.94	18,885.440	14,818.201	0.00	22.94	232.78
544.60	25.50	20,387.693	15,227.793	0.00	25.50	252.03
544.70	29.90	21,931.185	15,642.969	0.00	29.90	273.58
544.80	35.54	23,516.473	16,063.729	0.00	35.54	296.83
544.90	42.20	25,144.117	16,490.073	0.00	42.20	321.58
545.00	49.78	26,814.674	16,922.000	0.00	49.78	347.72
545.10	58.13	28,526.351	17,312.278	0.00	58.13	375.09
545.20	67.25	30,277.278	17,707.005	0.00	67.25	403.66
545.30	77.04	32,067.900	18,106.181	0.00	77.04	433.35
545.40	87.45	33,898.662	18,509.807	0.00	87.45	464.10
545.50	97.32	35,770.010	18,917.883	0.00	97.32	494.76
545.60	108.18	37,682.387	19,330.407	0.00	108.18	526.87
545.70	117.84	39,636.239	19,747.381	0.00	117.84	558.24
545.80	121.71	41,632.012	20,168.805	0.00	121.71	584.29
545.90	122.84	43,670.149	20,594.678	0.00	122.84	608.06
546.00	123.97	45,751.096	21,025.000	0.00	123.97	632.31
546.10	125.11	47,862.913	21,211.478	0.00	125.11	656.92
546.20	126.26	49,993.419	21,398.780	0.00	126.26	681.75
546.30	127.44	52,142.696	21,586.905	0.00	127.44	706.80
546.40	128.60	54,310.827	21,775.854	0.00	128.60	732.05
546.50	129.78	56,497.894	21,965.625	0.00	129.78	757.53
546.60	130.94	58,703.980	22,156.220	0.00	130.94	783.21
546.70	132.11	60,929.166	22,347.639	0.00	132.11	809.10
546.80	133.27	63,173.535	22,539.880	0.00	133.27	835.20
546.90	134.44	65,437.169	22,732.945	0.00	134.44	861.52
547.00	135.61	67,720.151	22,926.834	0.00	135.61	888.05
547.10	136.77	70,022.563	23,121.545	0.00	136.77	914.80
547.20	137.92	72,344.488	23,317.080	0.00	137.92	941.75
547.30	139.07	74,686.007	23,513.439	0.00	139.07	968.92
547.40	140.21	77,047.203	23,710.620	0.00	140.21	996.29
547.50	141.37	79,428.158	23,908.625	0.00	141.37	1,023.91
547.60	142.50	81,828.956	24,107.454	0.00	142.50	1,051.71
547.70	143.63	84,249.677	24,307.105	0.00	143.63	1,079.73
547.80	144.76	86,690.404	24,507.580	0.00	144.76	1,107.98
547.90	145.88	89,151.220	24,708.878	0.00	145.88	1,136.45
548.00	146.99	91,632.207	24,911.000	0.00	146.99	1,165.13

PROPOSED CONDITIONS

Subsection: Level Pool Pond Routing Summary

Return Event: 2 years

Label: Basin B (IN)

Storm Event: TypeII 24hr (3.25 in)

Infiltration			
Infiltration Method (Computed)	No Infiltration		
Initial Conditions			
Elevation (Water Surface, Initial)	541.00 ft		
Volume (Initial)	0.000 ft ³		
Flow (Initial Outlet)	0.00 ft ³ /s		
Flow (Initial Infiltration)	0.00 ft ³ /s		
Flow (Initial, Total)	0.00 ft ³ /s		
Time Increment	0.050 hours		
Inflow/Outflow Hydrograph Summary			
Flow (Peak In)	38.61 ft ³ /s	Time to Peak (Flow, In)	12.050 hours
Flow (Peak Outlet)	22.40 ft ³ /s	Time to Peak (Flow, Outlet)	12.250 hours
Peak Conditions			
Elevation (Water Surface, Peak)	544.36 ft		
Volume (Peak)	16,853.373 ft ³		
Mass Balance (ft ³)			
Volume (Initial)	0.000 ft ³		
Volume (Total Inflow)	136,031.000 ft ³		
Volume (Total Infiltration)	0.000 ft ³		
Volume (Total Outlet Outflow)	136,031.000 ft ³		
Volume (Retained)	0.000 ft ³		
Volume (Unrouted)	0.000 ft ³		
Error (Mass Balance)	0.0 %		

PROPOSED CONDITIONS

Subsection: Level Pool Pond Routing Summary
 Label: Basin B (IN)

Return Event: 10 years
 Storm Event: TypeII 24hr (5.0 in)

Infiltration	
Infiltration Method (Computed)	No Infiltration

Initial Conditions	
Elevation (Water Surface, Initial)	541.00 ft
Volume (Initial)	0.000 ft ³
Flow (Initial Outlet)	0.00 ft ³ /s
Flow (Initial Infiltration)	0.00 ft ³ /s
Flow (Initial, Total)	0.00 ft ³ /s
Time Increment	0.050 hours

Inflow/Outflow Hydrograph Summary			
Flow (Peak In)	77.04 ft ³ /s	Time to Peak (Flow, In)	12.050 hours
Flow (Peak Outlet)	68.99 ft ³ /s	Time to Peak (Flow, Outlet)	12.150 hours

Elevation (Water Surface, Peak)	545.22 ft
Volume (Peak)	30,593.613 ft ³

Mass Balance (ft ³)	
Volume (Initial)	0.000 ft ³
Volume (Total Inflow)	247,651.000 ft ³
Volume (Total Infiltration)	0.000 ft ³
Volume (Total Outlet Outflow)	247,651.000 ft ³
Volume (Retained)	0.000 ft ³
Volume (Unrouted)	0.000 ft ³
Error (Mass Balance)	0.0 %

PROPOSED CONDITIONS

Subsection: Level Pool Pond Routing Summary
 Label: Basin B (IN)

Return Event: 100 years
 Storm Event: TypeII 24hr (8.0 in)

Infiltration			
Infiltration Method (Computed)	No Infiltration		
Initial Conditions			
Elevation (Water Surface, Initial)	541.00 ft		
Volume (Initial)	0.000 ft ³		
Flow (Initial Outlet)	0.00 ft ³ /s		
Flow (Initial Infiltration)	0.00 ft ³ /s		
Flow (Initial, Total)	0.00 ft ³ /s		
Time Increment	0.050 hours		
Inflow/Outflow Hydrograph Summary			
Flow (Peak In)	145.91 ft ³ /s	Time to Peak (Flow, In)	12.050 hours
Flow (Peak Outlet)	124.75 ft ³ /s	Time to Peak (Flow, Outlet)	12.150 hours
Peak Conditions			
Elevation (Water Surface, Peak)	546.07 ft		
Volume (Peak)	47,200.067 ft ³		
Mass Balance (ft ³)			
Volume (Initial)	0.000 ft ³		
Volume (Total Inflow)	478,172.000 ft ³		
Volume (Total Infiltration)	0.000 ft ³		
Volume (Total Outlet Outflow)	478,172.000 ft ³		
Volume (Retained)	0.000 ft ³		
Volume (Unrouted)	0.000 ft ³		
Error (Mass Balance)	0.0 %		

PROPOSED CONDITIONS

Subsection: Pond Routed Hydrograph (total out)
 Label: Basin B (OUT)

Return Event: 2 years
 Storm Event: TypeII 24hr (3.25 in)

Peak Discharge	22.40 ft ³ /s
Time to Peak	12.250 hours
Hydrograph Volume	136,030.984 ft ³

HYDROGRAPH ORDINATES (ft³/s) Output Time Increment = 0.050 hours

Time on left represents time for first value in each row.

Time (hours)	Flow (ft ³ /s)	Flow (ft ³ /s)	Flow (ft ³ /s)	Flow (ft ³ /s)	Flow (ft ³ /s)
9.000	0.00	0.00	0.00	0.01	0.01
9.250	0.02	0.03	0.04	0.05	0.06
9.500	0.07	0.08	0.09	0.10	0.11
9.750	0.12	0.13	0.15	0.16	0.18
10.000	0.19	0.21	0.23	0.25	0.27
10.250	0.29	0.31	0.33	0.36	0.39
10.500	0.41	0.44	0.47	0.51	0.54
10.750	0.58	0.63	0.67	0.72	0.77
11.000	0.83	0.89	0.95	1.02	1.10
11.250	1.19	1.29	1.41	1.54	1.67
11.500	1.82	2.02	2.35	2.97	4.04
11.750	5.75	8.31	12.02	13.73	16.16
12.000	18.46	20.02	21.13	21.89	22.30
12.250	22.40	22.25	21.93	21.47	20.89
12.500	20.19	19.27	18.03	16.11	13.67
12.750	8.67	4.90	4.60	4.36	4.17
13.000	4.00	3.85	3.71	3.58	3.46
13.250	3.36	3.26	3.17	3.09	3.01
13.500	2.94	2.86	2.79	2.72	2.66
13.750	2.59	2.53	2.48	2.42	2.37
14.000	2.31	2.26	2.21	2.16	2.12
14.250	2.08	2.05	2.02	2.00	1.98
14.500	1.96	1.94	1.92	1.90	1.88
14.750	1.87	1.85	1.83	1.81	1.79
15.000	1.78	1.76	1.74	1.72	1.70
15.250	1.68	1.67	1.65	1.63	1.61
15.500	1.59	1.57	1.55	1.54	1.52
15.750	1.50	1.48	1.46	1.44	1.42
16.000	1.40	1.38	1.37	1.35	1.33
16.250	1.32	1.31	1.30	1.29	1.28
16.500	1.28	1.27	1.26	1.25	1.25
16.750	1.24	1.23	1.23	1.22	1.21
17.000	1.21	1.20	1.20	1.19	1.18
17.250	1.17	1.17	1.16	1.15	1.15
17.500	1.14	1.14	1.13	1.12	1.12
17.750	1.11	1.10	1.09	1.09	1.08
18.000	1.07	1.07	1.06	1.05	1.05

PROPOSED CONDITIONS

Subsection: Pond Routed Hydrograph (total out)

Return Event: 2 years

Label: Basin B (OUT)

Storm Event: TypeII 24hr (3.25 in)

HYDROGRAPH ORDINATES (ft³/s)

Output Time Increment = 0.050 hours

Time on left represents time for first value in each row.

Time (hours)	Flow (ft ³ /s)	Flow (ft ³ /s)	Flow (ft ³ /s)	Flow (ft ³ /s)	Flow (ft ³ /s)
18.250	1.04	1.03	1.03	1.02	1.01
18.500	1.01	1.00	0.99	0.99	0.98
18.750	0.97	0.96	0.96	0.95	0.94
19.000	0.94	0.93	0.92	0.92	0.91
19.250	0.90	0.89	0.89	0.88	0.87
19.500	0.87	0.86	0.85	0.85	0.84
19.750	0.83	0.82	0.82	0.81	0.80
20.000	0.80	0.79	0.78	0.78	0.77
20.250	0.77	0.76	0.76	0.76	0.76
20.500	0.75	0.75	0.75	0.75	0.75
20.750	0.75	0.75	0.74	0.74	0.74
21.000	0.74	0.74	0.74	0.74	0.74
21.250	0.73	0.73	0.73	0.73	0.73
21.500	0.73	0.73	0.72	0.72	0.72
21.750	0.72	0.72	0.72	0.72	0.72
22.000	0.71	0.71	0.71	0.71	0.71
22.250	0.71	0.71	0.70	0.70	0.70
22.500	0.70	0.70	0.70	0.70	0.70
22.750	0.69	0.69	0.69	0.69	0.69
23.000	0.69	0.69	0.68	0.68	0.68
23.250	0.68	0.68	0.68	0.68	0.68
23.500	0.67	0.67	0.67	0.67	0.67
23.750	0.67	0.67	0.66	0.72	1.18
24.000	2.83	6.02	9.33	10.78	9.87
24.250	7.54	5.10	3.29	2.16	1.43
24.500	0.94	0.61	0.40	0.27	0.18
24.750	0.12	0.08	0.04	0.02	0.00
25.000	0.00	(N/A)	(N/A)	(N/A)	(N/A)

PROPOSED CONDITIONS

Subsection: Pond Routed Hydrograph (total out)
 Label: Basin B (OUT)

Return Event: 10 years
 Storm Event: TypeII 24hr (5.0 in)

Peak Discharge	68.99 ft ³ /s
Time to Peak	12.150 hours
Hydrograph Volume	247,549.035 ft ³

HYDROGRAPH ORDINATES (ft³/s) Output Time Increment = 0.050 hours

Time on left represents time for first value in each row.

Time (hours)	Flow (ft ³ /s)	Flow (ft ³ /s)	Flow (ft ³ /s)	Flow (ft ³ /s)	Flow (ft ³ /s)
6.850	0.00	0.00	0.01	0.01	0.02
7.100	0.02	0.03	0.04	0.05	0.06
7.350	0.07	0.08	0.09	0.10	0.11
7.600	0.12	0.13	0.14	0.15	0.16
7.850	0.17	0.18	0.19	0.20	0.22
8.100	0.23	0.24	0.25	0.27	0.28
8.350	0.30	0.31	0.33	0.35	0.37
8.600	0.39	0.41	0.43	0.45	0.48
8.850	0.50	0.53	0.55	0.58	0.60
9.100	0.63	0.65	0.68	0.70	0.72
9.350	0.74	0.76	0.78	0.80	0.82
9.600	0.84	0.86	0.88	0.91	0.94
9.850	0.98	1.02	1.06	1.10	1.14
10.100	1.19	1.24	1.29	1.35	1.41
10.350	1.47	1.54	1.61	1.68	1.75
10.600	1.83	1.91	2.00	2.10	2.21
10.850	2.32	2.44	2.56	2.69	2.83
11.100	2.97	3.14	3.32	3.54	3.78
11.350	4.06	4.35	4.66	5.00	5.43
11.600	6.20	7.66	10.16	12.83	14.63
11.850	17.27	19.53	21.49	26.71	51.17
12.100	66.75	68.99	62.55	52.81	43.28
12.350	35.59	29.90	25.87	23.43	22.63
12.600	22.19	21.68	21.10	20.45	19.63
12.850	18.63	17.27	15.33	13.32	9.36
13.100	6.68	6.44	6.22	6.03	5.85
13.350	5.69	5.54	5.40	5.26	5.12
13.600	4.99	4.86	4.74	4.62	4.51
13.850	4.41	4.31	4.21	4.11	4.02
14.100	3.93	3.84	3.76	3.70	3.64
14.350	3.59	3.55	3.51	3.47	3.43
14.600	3.40	3.37	3.33	3.30	3.27
14.850	3.23	3.20	3.17	3.13	3.10
15.100	3.07	3.03	3.00	2.97	2.93
15.350	2.90	2.87	2.83	2.80	2.77
15.600	2.73	2.70	2.67	2.63	2.60
15.850	2.56	2.53	2.50	2.46	2.43

PROPOSED CONDITIONS

Subsection: Pond Routed Hydrograph (total out)
 Label: Basin B (OUT)

Return Event: 10 years
 Storm Event: TypeII 24hr (5.0 in)

HYDROGRAPH ORDINATES (ft³/s) Output Time Increment = 0.050 hours

Time on left represents time for first value in each row.

Time (hours)	Flow (ft ³ /s)	Flow (ft ³ /s)	Flow (ft ³ /s)	Flow (ft ³ /s)	Flow (ft ³ /s)
16.100	2.40	2.37	2.34	2.31	2.29
16.350	2.28	2.26	2.25	2.23	2.22
16.600	2.21	2.20	2.18	2.17	2.16
16.850	2.15	2.14	2.12	2.11	2.10
17.100	2.09	2.08	2.06	2.05	2.04
17.350	2.03	2.02	2.00	1.99	1.98
17.600	1.97	1.96	1.94	1.93	1.92
17.850	1.91	1.90	1.88	1.87	1.86
18.100	1.85	1.84	1.82	1.81	1.80
18.350	1.79	1.77	1.76	1.75	1.74
18.600	1.73	1.71	1.70	1.69	1.68
18.850	1.66	1.65	1.64	1.63	1.61
19.100	1.60	1.59	1.58	1.57	1.55
19.350	1.54	1.53	1.52	1.50	1.49
19.600	1.48	1.47	1.45	1.44	1.43
19.850	1.42	1.40	1.39	1.38	1.37
20.100	1.36	1.34	1.34	1.33	1.32
20.350	1.32	1.31	1.31	1.31	1.30
20.600	1.30	1.30	1.29	1.29	1.29
20.850	1.29	1.29	1.28	1.28	1.28
21.100	1.28	1.27	1.27	1.27	1.27
21.350	1.26	1.26	1.26	1.26	1.25
21.600	1.25	1.25	1.25	1.25	1.24
21.850	1.24	1.24	1.24	1.23	1.23
22.100	1.23	1.23	1.22	1.22	1.22
22.350	1.22	1.21	1.21	1.21	1.21
22.600	1.20	1.20	1.20	1.20	1.19
22.850	1.19	1.19	1.19	1.19	1.18
23.100	1.18	1.18	1.18	1.17	1.17
23.350	1.17	1.17	1.16	1.16	1.16
23.600	1.16	1.15	1.15	1.15	1.15
23.850	1.14	1.14	1.14	1.14	(N/A)

PROPOSED CONDITIONS

Subsection: Pond Routed Hydrograph (total out)
 Label: Basin B (OUT)

Return Event: 100 years
 Storm Event: TypeII 24hr (8.0 in)

Peak Discharge	124.75 ft ³ /s
Time to Peak	12.150 hours
Hydrograph Volume	478,171.665 ft ³

HYDROGRAPH ORDINATES (ft³/s)

Output Time Increment = 0.050 hours

Time on left represents time for first value in each row.

Time (hours)	Flow (ft ³ /s)	Flow (ft ³ /s)	Flow (ft ³ /s)	Flow (ft ³ /s)	Flow (ft ³ /s)
4.800	0.00	0.00	0.00	0.01	0.02
5.050	0.03	0.04	0.06	0.07	0.09
5.300	0.10	0.12	0.13	0.15	0.17
5.550	0.18	0.20	0.22	0.23	0.25
5.800	0.27	0.29	0.31	0.32	0.34
6.050	0.36	0.38	0.40	0.42	0.43
6.300	0.45	0.47	0.49	0.51	0.53
6.550	0.55	0.57	0.59	0.61	0.63
6.800	0.65	0.67	0.69	0.71	0.73
7.050	0.75	0.78	0.80	0.82	0.84
7.300	0.86	0.88	0.90	0.93	0.95
7.550	0.97	0.99	1.01	1.03	1.06
7.800	1.08	1.10	1.12	1.15	1.17
8.050	1.19	1.22	1.24	1.27	1.31
8.300	1.35	1.39	1.44	1.48	1.53
8.550	1.58	1.64	1.69	1.74	1.80
8.800	1.86	1.92	1.98	2.04	2.10
9.050	2.16	2.22	2.28	2.33	2.38
9.300	2.42	2.46	2.50	2.53	2.56
9.550	2.59	2.62	2.66	2.71	2.77
9.800	2.83	2.91	3.00	3.09	3.19
10.050	3.29	3.39	3.50	3.62	3.75
10.300	3.88	4.02	4.17	4.32	4.48
10.550	4.64	4.81	4.99	5.18	5.39
10.800	5.62	5.86	6.12	6.38	6.65
11.050	6.94	7.24	7.59	7.98	8.43
11.300	8.94	9.51	10.12	10.75	11.44
11.550	12.32	12.81	13.97	15.91	18.23
11.800	20.24	22.19	39.04	77.27	108.99
12.050	122.14	124.12	124.75	123.32	113.63
12.300	83.26	63.39	50.94	42.35	36.18
12.550	31.58	28.02	25.24	23.52	22.74
12.800	22.41	22.06	21.66	21.23	20.76
13.050	20.24	19.62	18.92	18.06	16.96
13.300	15.62	14.30	13.08	11.30	9.22
13.550	8.98	8.75	8.52	8.30	8.10
13.800	7.90	7.72	7.54	7.36	7.19

PROPOSED CONDITIONS

Subsection: Pond Routed Hydrograph (total out)
 Label: Basin B (OUT)

Return Event: 100 years
 Storm Event: TypeII 24hr (8.0 in)

HYDROGRAPH ORDINATES (ft³/s) Output Time Increment = 0.050 hours

Time on left represents time for first value in each row.

Time (hours)	Flow (ft ³ /s)	Flow (ft ³ /s)	Flow (ft ³ /s)	Flow (ft ³ /s)	Flow (ft ³ /s)
14.050	7.02	6.86	6.71	6.57	6.45
14.300	6.35	6.26	6.19	6.12	6.05
14.550	5.99	5.92	5.86	5.80	5.74
14.800	5.69	5.63	5.57	5.51	5.45
15.050	5.39	5.33	5.27	5.21	5.16
15.300	5.10	5.04	4.98	4.92	4.86
15.550	4.80	4.74	4.68	4.62	4.56
15.800	4.51	4.45	4.39	4.33	4.27
16.050	4.21	4.15	4.10	4.05	4.01
16.300	3.97	3.94	3.91	3.89	3.86
16.550	3.84	3.82	3.80	3.78	3.75
16.800	3.73	3.71	3.69	3.67	3.65
17.050	3.63	3.61	3.59	3.56	3.54
17.300	3.52	3.50	3.48	3.46	3.44
17.550	3.42	3.40	3.37	3.35	3.33
17.800	3.31	3.29	3.27	3.25	3.23
18.050	3.20	3.18	3.16	3.14	3.12
18.300	3.10	3.08	3.06	3.03	3.01
18.550	2.99	2.97	2.95	2.93	2.91
18.800	2.88	2.86	2.84	2.82	2.80
19.050	2.78	2.76	2.73	2.71	2.69
19.300	2.67	2.65	2.63	2.61	2.58
19.550	2.56	2.54	2.52	2.50	2.48
19.800	2.46	2.43	2.41	2.39	2.37
20.050	2.35	2.33	2.31	2.29	2.28
20.300	2.27	2.26	2.25	2.25	2.24
20.550	2.24	2.23	2.23	2.22	2.22
20.800	2.21	2.21	2.20	2.20	2.20
21.050	2.19	2.19	2.18	2.18	2.18
21.300	2.17	2.17	2.16	2.16	2.15
21.550	2.15	2.15	2.14	2.14	2.13
21.800	2.13	2.13	2.12	2.12	2.11
22.050	2.11	2.10	2.10	2.10	2.09
22.300	2.09	2.08	2.08	2.07	2.07
22.550	2.07	2.06	2.06	2.05	2.05
22.800	2.04	2.04	2.04	2.03	2.03
23.050	2.02	2.02	2.01	2.01	2.01
23.300	2.00	2.00	1.99	1.99	1.98
23.550	1.98	1.98	1.97	1.97	1.96
23.800	1.96	1.96	1.95	1.95	1.94
24.050	1.91	1.79	1.55	1.21	0.86
24.300	0.57	0.37	0.24	0.16	0.10

PROPOSED CONDITIONS

Subsection: Pond Routed Hydrograph (total out)
Label: Basin B (OUT)

Return Event: 100 years
Storm Event: TypeII 24hr (8.0 in)

HYDROGRAPH ORDINATES (ft³/s)

Output Time Increment = 0.050 hours

Time on left represents time for first value in each row.

Time (hours)	Flow (ft ³ /s)	Flow (ft ³ /s)	Flow (ft ³ /s)	Flow (ft ³ /s)	Flow (ft ³ /s)
24.550	0.07	0.04	0.03	0.02	0.01
24.800	0.01	0.00	0.00	0.00	(N/A)

PROPOSED CONDITIONS

Subsection: Pond Inflow Summary

Return Event: 2 years

Label: Basin B (IN)

Storm Event: TypeII 24hr (3.25 in)

Summary for Hydrograph Addition at 'Basin B'

Upstream Link	Upstream Node
<Catchment to Outflow Node>	Area B

Node Inflows

Inflow Type	Element	Volume (ft ³)	Time to Peak (hours)	Flow (Peak) (ft ³ /s)
Flow (From)	Area B	136,031.020	12.050	38.61
Flow (In)	Basin B	136,031.020	12.050	38.61

PROPOSED CONDITIONS

Subsection: Pond Inflow Summary
Label: Basin B (IN)

Return Event: 10 years
Storm Event: TypeII 24hr (5.0 in)

Summary for Hydrograph Addition at 'Basin B'

Upstream Link	Upstream Node
<Catchment to Outflow Node>	Area B

Node Inflows

Inflow Type	Element	Volume (ft ³)	Time to Peak (hours)	Flow (Peak) (ft ³ /s)
Flow (From)	Area B	247,651.404	12.050	77.04
Flow (In)	Basin B	247,651.404	12.050	77.04

PROPOSED CONDITIONS

Subsection: Pond Inflow Summary
Label: Basin B (IN)

Return Event: 100 years
Storm Event: TypeII 24hr (8.0 in)

Summary for Hydrograph Addition at 'Basin B'

Upstream Link	Upstream Node
<Catchment to Outflow Node>	Area B

Node Inflows

Inflow Type	Element	Volume (ft ³)	Time to Peak (hours)	Flow (Peak) (ft ³ /s)
Flow (From)	Area B	478,171.724	12.050	145.91
Flow (In)	Basin B	478,171.724	12.050	145.91

PROPOSED CONDITIONS

Index

A

- Area A (Runoff CN-Area, 2 years)...22
- Area A (Time of Concentration Calculations, 2 years)...14, 15, 16
- Area A (Unit Hydrograph Summary, 10 years)...29, 30
- Area A (Unit Hydrograph Summary, 100 years)...31, 32
- Area A (Unit Hydrograph Summary, 2 years)...27, 28
- Area B (Runoff CN-Area, 2 years)...23
- Area B (Time of Concentration Calculations, 2 years)...17, 18, 19
- Area B (Unit Hydrograph Summary, 10 years)...35, 36
- Area B (Unit Hydrograph Summary, 100 years)...37, 38
- Area B (Unit Hydrograph Summary, 2 years)...33, 34

B

- Basin A (Elevation-Area Volume Curve, 2 years)...48
- Basin A (Elevation-Volume-Flow Table (Pond), 2 years)...60, 61, 62
- Basin A (IN) (Level Pool Pond Routing Summary, 10 years)...64
- Basin A (IN) (Level Pool Pond Routing Summary, 100 years)...65
- Basin A (IN) (Level Pool Pond Routing Summary, 2 years)...63
- Basin A (IN) (Pond Inflow Summary, 10 years)...73
- Basin A (IN) (Pond Inflow Summary, 100 years)...74
- Basin A (IN) (Pond Inflow Summary, 2 years)...72
- Basin A (OUT) (Pond Routed Hydrograph (total out), 10 years)...68, 69
- Basin A (OUT) (Pond Routed Hydrograph (total out), 100 years)...70, 71
- Basin A (OUT) (Pond Routed Hydrograph (total out), 2 years)...66, 67
- Basin A (Volume Equations, 2 years)...49
- Basin B (Elevation-Area Volume Curve, 2 years)...50
- Basin B (Elevation-Volume-Flow Table (Pond), 2 years)...75, 76
- Basin B (IN) (Level Pool Pond Routing Summary, 10 years)...78
- Basin B (IN) (Level Pool Pond Routing Summary, 100 years)...79
- Basin B (IN) (Level Pool Pond Routing Summary, 2 years)...77
- Basin B (IN) (Pond Inflow Summary, 10 years)...88

PROPOSED CONDITIONS

Basin B (IN) (Pond Inflow Summary, 100 years)...89
Basin B (IN) (Pond Inflow Summary, 2 years)...87
Basin B (OUT) (Pond Routed Hydrograph (total out), 10 years)...82, 83
Basin B (OUT) (Pond Routed Hydrograph (total out), 100 years)...84, 85, 86
Basin B (OUT) (Pond Routed Hydrograph (total out), 2 years)...80, 81
Basin B (Volume Equations, 2 years)...51
BY-PASS (Runoff CN-Area, 2 years)...24
BY-PASS (Time of Concentration Calculations, 2 years)...20, 21
BY-PASS (Unit Hydrograph Summary, 10 years)...41, 42
BY-PASS (Unit Hydrograph Summary, 100 years)...43, 44
BY-PASS (Unit Hydrograph Summary, 2 years)...39, 40
C
Composite Outlet Structure - A (Outlet Input Data, 2 years)...52, 53, 54, 55
Composite Outlet Structure - B (Outlet Input Data, 2 years)...56, 57, 58, 59
M
Master Network Summary...5, 6, 7
O
O-14 (Addition Summary, 10 years)...46
O-14 (Addition Summary, 100 years)...47
O-14 (Addition Summary, 2 years)...45
S
St. Charles County (Time-Depth Curve, 10 years)...10, 11
St. Charles County (Time-Depth Curve, 100 years)...12, 13
St. Charles County (Time-Depth Curve, 2 years)...8, 9
U
Unit Hydrograph Equations...25, 26
User Notifications...2, 3, 4